



USER MANUAL



EXTENDER APPLICATION MODE

UBEX-PRO20-HDMI-F100
UBEX-PRO20-HDMI-F110
UBEX-PRO20-HDMI-F111
UBEX-PRO20-HDMI-F120
UBEX-PRO20-HDMI-F121
UBEX-PRO20-HDMI-F130

UBEX-PRO20-HDMI-R100 2xMM-2xDUO
UBEX-PRO20-HDMI-R100 2xMM-QUAD
UBEX-PRO20-HDMI-R100 2xSM-2xDUO
UBEX-PRO20-HDMI-R100 2xSM-QUAD
UBEX-PRO20-HDMI-R100 2xSM-BiDi-DUO

AV Over IP Multimedia Extender

Bookmark Page

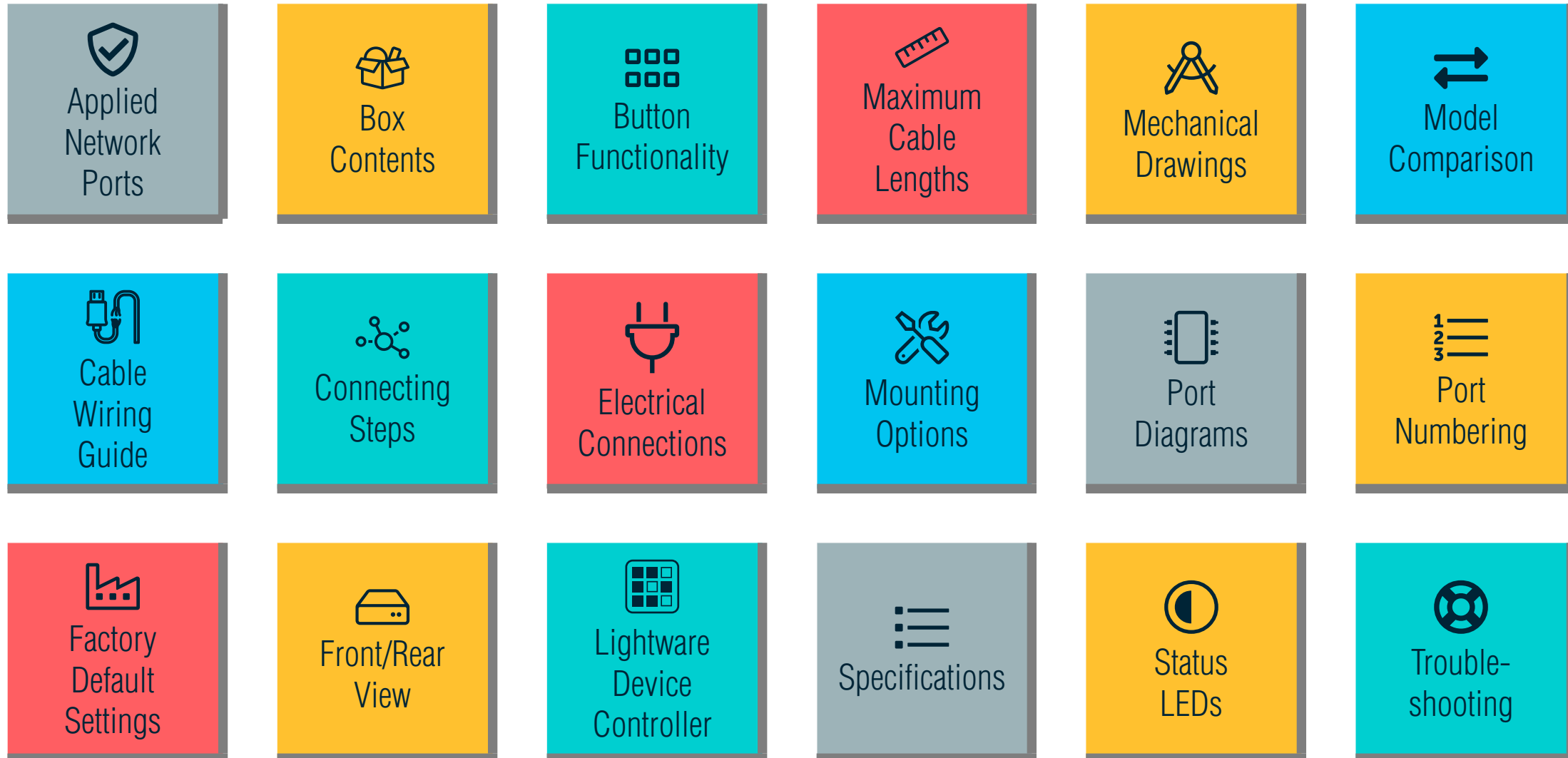

Important Safety Instructions

Class I apparatus construction.

This equipment must be used with a mains power system with a protective earth connection. The third (earth) pin is a safety feature, do not bypass or disable it. The equipment should be operated only from the power source indicated on the product.

To disconnect the equipment safely from power, remove the power cord from the rear of the equipment or from the power source. The MAINS plug is used as the disconnect device, the disconnect device shall remain readily operable.

There are no user-serviceable parts inside of the unit. Removal of the cover will expose dangerous voltages. To avoid personal injury, do not remove the cover. Do not operate the unit without the cover installed.

The appliance must be safely connected to multimedia systems. Follow instructions described in this manual.

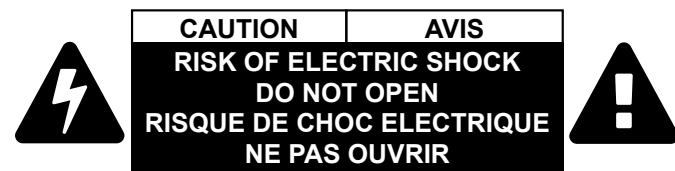

Ventilation

For the correct ventilation and to avoid overheating, ensure enough free space around the appliance. Do not cover the appliance, leave the ventilation holes free and never block or bypass the ventilators (if there are any).

WARNING

To prevent injury, the apparatus is recommended to be securely attach to the floor/wall, or mounted in accordance with the installation instructions. The apparatus shall not be exposed to dripping or splashing, and no objects filled with liquids, such as vases, shall be placed on the apparatus. No naked flame sources, such as lit candles, should be placed on the apparatus.

Waste Electrical & Electronic Equipment (WEEE)

This marking shown on the product or its literature indicates that it should not be disposed with other household wastes at the end of its working life. To prevent possible harm to the environment or human health from uncontrolled waste disposal, please separate this from other types of wastes and recycle it responsibly to promote the sustainable reuse of material resources. Household users should contact either the retailer where they purchased this product or their local government office for details of where and how they can take this item for environmentally safe recycling. Business users should contact their supplier and check the terms and conditions of the purchase contract. This product should not be mixed with other commercial wastes for disposal.

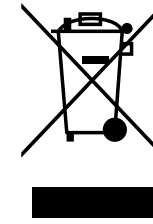

Common Safety Symbols

Symbol	Description
	Alternating current
	Protective conductor terminal
	Caution, possibility of electric shock
	Caution
	Laser radiation

Table of Contents

1. INTRODUCTION	10	3.7. PORTS MENU - MULTIVIEWER OPERATION MODE	32	4.5. CONNECTIONS	45
1.1. DESCRIPTION	11	3.7.1. TX I1 and TX I2 Ports	33	4.5.1. F-series Endpoints - Transmitter Operation Mode	45
1.2. BOX CONTENTS	12	3.7.2. RXMV O1 and RXMV O2 Ports	33	4.5.2. F-series Endpoints - Receiver Operation Mode	46
1.3. MODEL COMPARISON	13	3.7.3. RX I1 and RX I2 Ports	33	4.5.3. F-series Endpoints - Transceiver Operation Mode	47
1.4. FEATURES	14	3.8. EDID MENU	33	4.5.4. F-series Endpoints - Multiviewer Operation Mode	48
1.5. AVAILABILITY OF THE ENDPOINT MODELS	15	3.8.1. View.....	33	4.5.5. F110 / F120 Model - USB K+M and Infrared Connections.....	49
1.6. APPLICATION MODES	16	3.8.2. Switch.....	34	4.5.6. R-series Endpoints - Transmitter Operation Mode	50
1.7. TYPICAL APPLICATIONS	16	3.8.3. Save.....	34	4.5.7. R-series Endpoints - Receiver Operation Mode	51
1.7.1. Transmitter-Receiver Pair	16	3.9. SYSTEM STATUS MENU	34	4.5.8. R-series Endpoints - Transceiver Operation Mode	52
1.7.2. Transceiver-Transceiver Pair	17	3.10. KM MENU	34	4.5.9. R-series Endpoints - Multiviewer Operation Mode	53
1.7.3. Multiviewer Application Diagram	17	3.10.1. U1	34	4.6. SFP+ SLOT CONNECTION	54
2. PRODUCT OVERVIEW	18	3.10.2. D1 and D2	34	4.6.1. Installation of SFP+ Modules	54
2.1. FRONT AND REAR VIEW - F-SERIES ENDPOINT DEVICES	19	3.11. SYSTEM SETTINGS MENU	35	4.6.2. Installation of DAC Cables	54
2.1.1. Front View	19	3.11.1. Network.....	35	4.7. FIBER OPTICAL CABLE CONNECTIONS	54
2.1.2. Rear View - F100 / F111 / F121 Models	20	3.11.2. Operation Mode.....	35	4.7.1. Connection between SFP+ Modules	54
2.1.3. Rear View - F130 Model	21	3.11.3. Application Mode	35	4.7.2. Connection between BiDi (Bidirectional) SFP+ Modules.....	54
2.1.4. Rear View - F110 / F120 Models	22	3.11.4. Front Panel.....	35	4.7.3. Connection between Neutrik opticalCON DUO Connectors	55
2.2. FRONT AND REAR VIEW - R-SERIES ENDPOINT DEVICES	23	3.11.5. Factory Defaults	35	4.7.4. Connection between Neutrik opticalCON DUO BiDi Connectors..	55
2.2.1. Front View	23	3.11.6. Restart Device	35	4.8. COPPER CABLE CONNECTIONS	55
2.2.2. Rear View	24	3.11.7. Bootload Mode.....	35	4.9. CONNECTION BETWEEN F-SERIES AND R-SERIES ENDPOINTS	55
3. FRONT PANEL LCD MENU OPERATIONS	25	4. INSTALLATION	36	4.9.1. SFP+ to Neutrik opticalCON DUO	55
3.1. THE TREE STRUCTURE OF THE LCD MENU	26	4.1. MOUNTING ACCESSORY COMPATIBILITY TABLE	37	4.9.2. SFP+ to Neutrik opticalCON QUAD	56
3.2. INTRODUCTION	27	4.2. MOUNTING OPTIONS - F-SERIES ENDPOINT DEVICES	38	4.9.3. SFP+ BiDi to Neutrik opticalCON DUO BiDi.....	57
3.2.1. Menu Navigation	27	4.2.1. Mounting Bracket V2.....	38	4.10. STARTUP OF THE SYSTEM	58
3.2.2. Operation Mode Visualization	27	4.2.2. UD Mounting Plate F120	38	4.10.1. Switch on the Devices	58
3.2.3. Parameter Selection.....	27	4.2.3. Rack Shelf Mounting	39	4.10.2. Configure the Operation Mode	58
3.3. HOME SCREEN	27	4.3. MOUNTING OPTIONS - R-SERIES ENDPOINT DEVICES	39	4.10.3. Establish the Connection with the UBEX Extenders	58
3.4. PORTS MENU - TRANSMITTER OPERATION MODE	28	4.3.1. Truss Mounting.....	39	4.10.4. Check the Signal Status	58
3.4.1. TX I1 and TX I2 Ports	28	4.3.2. Standard Rack Installation with Two Units	40	4.10.5. Set the Source MUX Settings	59
3.4.2. RX O1 and RX O2 Ports	28	4.3.3. Standard Rack Installation with One Unit	41	4.10.6. Set the HDCP Settings	59
3.4.3. TX O1 and TX O2 Ports	29	4.4. ELECTRICAL CONNECTIONS	42	4.10.7. Emulate the Correct EDID	59
3.5. PORTS MENU - RECEIVER OPERATION MODE	29	4.4.1. SFP / SFP+ Slots	42	4.10.8. Set the Scalers.....	60
3.5.1. TX I1 and TX I2 Ports	29	4.4.2. HDMI Connector	42	4.10.9. Set the Audio Streams	61
3.5.2. RX O1 and RX O2 Ports	29	4.4.3. AC Power Connection	42	4.10.10. Checkpoints for the Seamless Switching.....	61
3.5.3. RX I1 and RX I2 Ports	30	4.4.4. Symmetrical Analog Stereo Audio Connector	43	5. UBEX CONCEPT	62
3.6. PORTS MENU - TRANSCIEVER OPERATION MODE	30	4.4.5. RS-232 Connector	43	5.1. VIDEO INTERFACE	63
3.6.1. L (Local) TRX I2 Port	30	4.4.6. Ethernet Connectors	43	5.1.1. Transmitter Mode	63
3.6.2. L (Local) TRX O1 Port.....	31	4.4.7. Neutrik opticalCON Connectors	44	5.1.2. Receiver Mode.....	64
3.6.3. R (Remote) TRX I2 Port.....	32	4.4.8. IR Connector	44	5.1.3. Transceiver Mode.....	65
3.6.4. R (Remote) TRX O1 Port	32	4.4.9. USB Mini-B Connector.....	44	5.1.4. Bandwidth Limitation	66
3.6.5. L (Local) TRX O2 Port.....	32	4.4.10. USB-A Connectors.....	44	5.1.5. HDMI Signal Transmission - Example for TX-RX Pair	67
		4.4.11. USB-B Connector	44	5.1.6. HDMI Signal Transmission - Example for TRX-TRX Pair	68
		4.4.12. USB-C Connector.....	44		

5.1.7. Timing Modes.....	69	6.4. VIDEO CROSSPOINT MENU.....	92	7. PROGRAMMERS REFERENCE.....	113
5.1.8. The Difference between the Image Positions of the Scaler.....	70	6.4.1. Transmitter-Receiver Pair.....	92	7.1. OVERVIEW.....	114
5.2. MULTIVIEWER MODE.....	70	6.4.2. Transceiver-Transceiver Pair.....	93	7.2. INSTRUCTIONS FOR THE TERMINAL APPLICATION USAGE.....	114
5.2.1. Activation of the Multiviewer Mode.....	70	6.4.3. Port Tiles.....	93	7.3. PROTOCOL RULES.....	114
5.2.2. Definitions.....	71	6.5. PROPERTIES WINDOWS - VIDEO LAYER.....	94	7.3.1. LW3 Tree Structure and Command Structure (Examples).....	114
5.2.3. Description.....	71	6.5.1. HDMI Input Ports (TX/TRX Modes).....	94	7.3.2. General Rules.....	114
5.2.4. Port Diagram.....	72	6.5.2. Local HDMI Output Ports (TX/TRX Modes).....	94	7.3.3. Command Types.....	115
5.2.5. Options and Features.....	73	6.5.3. Scaler Panel - Input Side (TX/TRX Modes).....	95	7.3.4. Prefix Summary.....	115
5.2.6. Multistream Feature of the Transmitter.....	73	6.5.4. Stream Properties Panels (TX/TRX Modes).....	96	7.3.5. Error Messages.....	115
5.3. MULTIVIEWER DESIGNER - TUTORIAL.....	73	6.5.5. Stream Switcher / Stream Tiles.....	96	7.3.6. Escaping.....	115
5.3.1. Installation.....	73	6.5.6. Scaler Panel - Output Side (RX/TRX Modes).....	97	7.3.7. Signature.....	116
5.3.2. Configuration.....	74	6.5.7. Local HDMI Input Ports (RX Mode).....	97	7.3.8. Subscription.....	116
5.4. AUDIO INTERFACE.....	76	6.5.8. HDMI Output Ports (RX/TRX Modes).....	98	7.3.9. Notifications about the Changes of the Properties.....	116
5.4.1. Transmitter Mode - F100 / R100 Models.....	76	6.5.9. SFP+ Link Panels (TX/RX/TRX Modes).....	98	7.3.10. Legend for the Control Commands.....	116
5.4.2. Receiver Mode - F100 / R100 Models.....	76	6.5.10. Source MUX Selector.....	99	7.4. SYSTEM COMMANDS.....	117
5.4.3. Transceiver Mode - F100 / R100 Models.....	77	6.5.11. Identify Stream / Identify Display.....	99	7.4.1. Set the Device Label.....	117
5.4.4. Transmitter Mode - F110/F111/F120/F121/F130 Models.....	78	6.5.12. Link Aggregation Status Indicator.....	99	7.4.2. Querying the Product Name.....	117
5.4.5. Receiver Mode - F110/F111/F120/F121/F130 Models.....	78	6.6. AUDIO CROSSPOINT MENU.....	100	7.4.3. Query the Firmware Package Version.....	117
5.4.6. Transceiver Mode - F110/F111/F120/F121/F130 Models.....	79	6.7. PROPERTIES WINDOWS - AUDIO LAYER.....	101	7.4.4. Display Custom Text on the LCD.....	117
5.4.7. Audio Signal Transmission - Example for TX-RX Pair.....	80	6.7.1. Analog Audio Input Port.....	101	7.4.5. Display Custom Color on the LCD.....	117
5.4.8. Audio Signal Transmission - Example for TRX-TRX Pair.....	81	6.7.2. Analog Audio Output Port.....	101	7.4.6. Identify the Device.....	118
5.5. ETHERNET CONTROL INTERFACE.....	82	6.7.3. Stream Switcher.....	102	7.4.7. Dark Mode Setting.....	118
5.6. SERIAL INTERFACE.....	83	6.8. DIAGNOSTIC TOOLS.....	102	7.4.8. Dark Mode Delay Setting.....	118
5.6.1. Technical Background.....	83	6.8.1. Frame Detector.....	102	7.4.9. Query the Operation Mode.....	118
5.6.2. RS-232 Signal Transmission – Example.....	83	6.8.2. No Sync Screen (Test Pattern).....	103	7.4.10. Set the Operation Mode.....	119
5.7. INFRARED INTERFACE.....	83	6.9. EDID MANAGEMENT MENU.....	103	7.4.11. Query the Application Mode.....	119
5.7.1. Technical Background.....	83	6.9.1. EDID Operations.....	104	7.4.12. Application Mode Selection.....	119
5.7.2. Infrared Signal Transmission - Example.....	84	6.9.2. Editing an EDID.....	104	7.4.13. Setting the Rotary Direction of the Jog Dial Knob.....	120
5.8. USB K+M INTERFACE (F120 AND F121 MODELS).....	84	6.9.3. Creating an EDID - Easy EDID Creator.....	105	7.4.14. Setting the Brightness of the LCD Screen.....	120
5.8.1. Technical Background.....	84	6.9.4. EDID Summary Window.....	105	7.4.15. Control Lock.....	120
5.8.2. USB K+M Extension - Example.....	84	6.10. CONTROL MENU.....	106	7.4.16. Bootload Mode Setting.....	120
5.9. USB KVM / USB 2.0 INTERFACE (F130 MODEL).....	85	6.10.1. Ethernet Tab.....	106	7.4.17. Restarting the Device.....	121
5.9.1. Technical Background.....	85	6.10.2. RS-232 Tab.....	106	7.4.18. Restore the Factory Default Settings.....	121
5.9.2. Pairing the Icron Devices.....	86	6.10.3. Infra Tab.....	107	7.5. VIDEO PORT SETTINGS - TRANSMITTER MODE.....	121
5.9.3. USB KVM and USB 2.0 Extension - Example.....	86	6.10.4. USB Tab.....	108	7.5.1. Query the Status of Source Port.....	121
5.10. SFP+ INTERFACE.....	87	6.11. SETTINGS MENU.....	109	7.5.2. Query the Status of Destination Port.....	122
5.11. REDUNDANT 10G LINK CHANNELS.....	87	6.11.1. Status Tab.....	109	7.5.3. Query the Video Crosspoint Setting.....	122
5.12. FURTHER BUILT-IN FEATURES.....	87	6.11.2. Network Tab.....	109	7.5.4. Switching the Stream.....	123
5.12.1. Device Cloning – Configuration Backup and Restore.....	87	6.11.3. Front Panel Tab.....	110	7.5.5. Switching a Stream to All Destinations.....	123
5.12.2. Advanced EDID Management.....	88	6.11.4. System Tab.....	110	7.5.6. Enable/Disable the Stream.....	123
5.13. SOFTWARE CONTROL MODES.....	88	6.12. CONFIGURATION CLONING (BACKUP TAB).....	111	7.5.7. Identify Stream.....	123
6. SOFTWARE CONTROL - LIGHTWARE DEVICE CONTROLLER.....	89	6.12.1. Cloning Steps in a Nutshell.....	111	7.5.8. Resolution Setting.....	123
6.1. INSTALL AND UPDATE.....	90	6.12.2. Save the Settings of the Device (Backup).....	111	7.5.9. Resolution Mode Setting.....	124
6.2. RUNNING THE LDC.....	90	6.12.3. Upload the Settings to a Device (Restore).....	111	7.5.10. Scaler - Image Position Setting.....	124
6.3. ESTABLISHING THE CONNECTION.....	91	6.13. TERMINAL WINDOW.....	112	7.5.11. Tile Resolution Setting.....	124

7.5.12. Color Space Converter Setting	125	7.7.14. Color Range Setting	137	7.11.6. Query the Resolution of the Stream	150
7.5.13. Color Range Setting	125	7.7.15. Color Depth Setting	137	7.11.7. Query the Bandwidth of the Stream	150
7.5.14. Color Depth Setting	125	7.7.16. Query the Timing Mode.....	138	7.11.8. Query the Bandwidth Limitation Indicator	150
7.5.15. Query the Timing Mode.....	125	7.7.17. Timing Mode Setting.....	138	7.11.9. Query the Link Aggregation Status	150
7.5.16. HDCP Setting (Input Port).....	126	7.7.18. Enable Signal Freeze	138	7.12. SFP+ MODULE INFORMATION.....	150
7.5.17. HDCP Setting (Output Port).....	126	7.7.19. Disable Signal Freeze	138	7.12.1. Query the Vendor.....	150
7.6. VIDEO PORT SETTINGS - RECEIVER MODE	127	7.7.20. No Sync Screen (Test Pattern) Mode.....	139	7.12.2. Query the Part Number	151
7.6.1. Query the Status of Source Port.....	127	7.7.21. No Sync Screen (Test Pattern) Color Setting	139	7.12.3. Query the Compliance.....	151
7.6.2. Query the Status of Destination Port	128	7.7.22. HDCP Setting (Input Port).....	139	7.12.4. Query the Maximum Allowed Cable Length	151
7.6.3. Query the Video Crosspoint Setting	128	7.7.23. HDCP Setting (Output Port).....	139	7.12.5. Query the Type of the Module	151
7.6.4. Switching the Stream	128	7.7.24. Querying the Source MUX Options.....	140	7.12.6. Query the Compatibility of the Module	151
7.6.5. Switching a Stream to All Destinations.....	128	7.7.25. Source MUX Setting	140	7.13. EDID MANAGEMENT	152
7.6.6. Disconnecting the Stream	128	7.8. MULTIVIEWER CONFIGURATION	140	7.13.1. Query the Emulated EDIDs.....	152
7.6.7. Enable/Disable the Stream	128	7.8.1. Setting the Resolution of the Canvas	140	7.13.2. Query the Validity of a Dynamic EDID	152
7.6.8. Resolution Mode Setting.....	129	7.8.2. Enabling/Disabling the Tile	140	7.13.3. Query the Preferred Resolution of a User EDID	152
7.6.9. Query the EDID Based Resolution	129	7.8.3. Tile Position Setting	141	7.13.4. Emulating an EDID on an Input Port.....	152
7.6.10. Resolution Setting	129	7.8.4. Tile Size Setting	141	7.13.5. Copy an EDID to User Memory	152
7.6.11. Scaler - Image Position Setting	129	7.8.5. Layer Order Setting.....	142	7.13.6. Deleting an EDID from User Memory	152
7.6.12. Color Space Converter Setting	130	7.8.6. Tile Opacity Setting	142	7.13.7. Resetting the Emulated EDIDs.....	153
7.6.13. Color Range Setting	130	7.8.7. Color Depth Setting	142	7.14. NETWORK CONFIGURATION	153
7.6.14. Color Depth Setting	130	7.8.8. Querying the Status of the Tile	143	7.14.1. Query the DHCP State.....	153
7.6.15. Query the Timing Mode.....	130	7.8.9. No Sync Screen (Test Pattern) Mode.....	143	7.14.2. Change the DHCP State.....	153
7.6.16. Timing Mode Setting.....	131	7.8.10. No Sync Screen (Test Pattern) Color Setting	143	7.14.3. Query the MAC Address.....	153
7.6.17. Enable Signal Freeze	131	7.8.11. HDCP Setting	144	7.14.4. Query the IP Address	153
7.6.18. Disable Signal Freeze	131	7.8.12. Identify Stream / Identify Display	144	7.14.5. Change the IP Address (Static)	153
7.6.19. No Sync Screen (Test Pattern) Mode.....	131	7.8.13. Querying the Source MUX Options.....	145	7.14.6. Query the Subnet Mask.....	153
7.6.20. No Sync Screen (Test Pattern) Color Setting	131	7.8.14. Source MUX Setting	145	7.14.7. Change the Subnet Mask (Static)	154
7.6.21. HDCP Setting (Input Port).....	132	7.9. AUDIO PORT SETTINGS.....	145	7.14.8. Query the Gateway Address	154
7.6.22. HDCP Setting (Output Port).....	132	7.9.1. Query the Status of Source Port.....	145	7.14.9. Change the Gateway Address (Static)	154
7.6.23. Identify Display	132	7.9.2. Query the Status of Destination Port	146	7.14.10. Apply Network Settings	154
7.6.24. Query the Source MUX Options.....	133	7.9.3. Query the Audio Crosspoint Setting	146	7.14.11. Query the IP Address of the Remote Endpoint.....	154
7.6.25. Source MUX Setting	133	7.9.4. Audio Stream Switching.....	147	7.15. RS-232 PORT CONFIGURATION	154
7.7. VIDEO PORT SETTINGS - TRANSCEIVER MODE	133	7.9.5. Switching a Stream to All Destinations.....	147	7.15.1. Query the Current Configuration	154
7.7.1. Query the Status of Source Port.....	133	7.9.6. Enable/Disable the Audio Stream	147	7.15.2. BAUD Rate Setting.....	155
7.7.2. Query the Status of Destination Port	134	7.10. ANALOG AUDIO PORT SETTINGS.....	147	7.15.3. Parity Setting	155
7.7.3. Switching the Stream	134	7.10.1. Setting the Volume in dB	147	7.15.4. Stopbits Setting	155
7.7.4. Disconnecting the Stream	135	7.10.2. Setting the Volume in Percent	147	7.15.5. Databits Setting	155
7.7.5. Enable/Disable the Stream	135	7.10.3. Setting the Balance	148	7.15.6. Command Injection TCP Port Setting.....	155
7.7.6. Identify Stream / Identify Display	135	7.10.4. Setting the Gain	148	7.16. INFRARED PORT CONFIGURATION	156
7.7.7. Resolution Mode Setting - Input Side.....	135	7.10.5. Mute/Unmute the Analog Audio Output Port	148	7.16.1. Enable/Disable the Port	156
7.7.8. Resolution Mode Setting - Output Side.....	136	7.11. SYSTEM MONITORING COMMANDS	148	7.16.2. Enable Command Injection	156
7.7.9. Query the EDID Based Resolution	136	7.11.1. Query Connected Device Presence	148	7.16.3. Change Command Injection Port Number	156
7.7.10. Resolution Setting	136	7.11.2. Query Video Signal Presence	149	7.16.4. Enable/Disable Output Signal Modulation.....	156
7.7.11. Scaler - Image Position Setting	136	7.11.3. Query Embedded Audio Presence.....	149	7.17. MESSAGE SENDING VIA COMMUNICATION PORTS.....	156
7.7.12. Tile Resolution Setting	137	7.11.4. Query the Status of the Analog Audio Output	149	7.17.1. Sending a Text (ASCII-format) via Serial Port	156
7.7.13. Color Space Converter Setting	137	7.11.5. Query the Signal Type	149	7.17.2. Sending a Binary Message (HEX-format) via Serial Port.....	157

7.17.3. Sending a Message (ASCII-format) via Serial Port	157	8.6. SUPPORTED MESSAGES	174	11. TECHNOLOGIES	202
7.17.4. Sending Hex Codes in Little-endian Format via IR Port	157	8.6.1. Requesting and Replying Device Information.....	174	11.1. EDID MANAGEMENT	203
7.17.5. Sending Hex Codes in Big-endian Format via IR Port	158	8.6.2. Ping	175	11.1.1. Understanding the EDID.....	203
7.18. USB K+M SETTINGS (F120 / F121 MODELS)	158	8.6.3. Requesting and Replying Extended Device Information.....	175	11.1.2. Advanced EDID Management.....	203
7.18.1. Switching the Emulated Port to the Remote Receiver	158	8.6.4. Pairing to a Device.....	176	11.2. HDCP MANAGEMENT	204
7.18.2. Switching the Local Emulated Port to the Local Receiver	158	8.6.5. Removing Device Pairing	176	11.2.1. Protected and Unprotected Content	204
7.18.3. Disconnecting the Receiver Port.....	159	8.6.6. Requesting and Replying Device Topology	177	11.2.2. Disable Unnecessary Encryption.....	204
7.18.4. Enable/Disable the Receiver Port.....	159	8.6.7. Using DHCP	178	11.2.3. HDCP v2.2.....	205
7.18.5. Querying the Presence of the USB-A Device	159	8.6.8. Using Static IP	178	11.3. PIXEL ACCURATE RECLOCKING	206
7.18.6. Querying the Product Name of the USB-A Device.....	159	8.6.9. Using Filtering Strategy	179	11.4. AV OVER IP	207
7.18.7. Querying the Manufacturer of the USB-A Device	159	8.6.10. Resetting Device.....	179	11.4.1. Basics.....	207
7.18.8. Querying the Serial Number of the USB-A Device	159	8.6.11. Requesting and Replying Configuration Response Data	179	11.4.2. What is TCP/IP?	207
7.18.9. Querying the Device Class of the USB-A Device.....	159	8.6.12. Requesting and Replying Link Status.....	181	11.4.3. Link Aggregation Protocol	207
7.18.10. Querying the Interface Classes of the USB-A Device.....	160	8.6.13. Removing All Pairings	182	11.4.4. Multicast DNS (mDNS) Protocol	207
7.18.11. Enable/Disable Power Sending of the USB-A Port.....	160	8.6.14. Force Pairing to Device	182	12. ASSEMBLY GUIDES	208
7.18.12. Enable/Disable Suspending of the USB-A Port.....	160	8.6.15. Resetting Force Pairing to Device	183	12.1. FRONT PLATE EXCHANGE FOR F-SERIES ENDPOINT DEVICES	209
7.19. USB KVM SETTINGS (F130 MODEL)	160	8.6.16. Writing the Extended Configuration Variable	183	12.1.1. Tool Requirements	209
7.19.1. Setting the Operation Mode of the Icron USB 2.0 Module.....	160	8.6.17. Requesting the Extended Configuration Variable	184	12.1.2. The Steps of the Front Plate Exchange.....	209
7.19.2. Querying the MAC Address of the Icron Module.....	161	9. FIRMWARE UPDATE	186	12.2. SFP+ MODULE CHANGING IN R-SERIES ENDPOINTS	212
7.19.3. Querying the IP Address of the Icron Module	161	9.1. PREPARATION	187	12.3. AIR FILTER FOAM CHANGING IN R-SERIES ENDPOINTS	213
7.19.4. Switching the Emulated Port to the Remote Receiver	161	9.1.1. About the Firmware Package (LFP2 File)	187	12.4. HIDDEN USB CONNECTOR FOR DEBUG PURPOSE	214
7.19.5. Switching the Local Emulated Port to the Local Receiver	161	9.1.2. LDU2 Installation	187	13. APPENDIX	215
7.19.6. Disconnecting the Receiver Port.....	161	9.2. RUNNING THE SOFTWARE	188	13.1. SPECIFICATION	216
7.19.7. Enable/Disable the Receiver Port.....	161	9.3. THE UPDATING STEPS	189	13.1.1. UBEX F-series Endpoints	216
7.19.8. Querying the Presence of the USB HID Device.....	162	9.3.1. The Correct Order of the Updating	190	13.1.2. UBEX R-series Endpoints	219
7.19.9. Querying the Product Name of the USB HID Device	162	9.3.2. The Steps of the Update in Quick Summary.....	190	13.2. APPLIED PORTS (NETWORK SETTINGS)	221
7.19.10. Querying the Manufacturer of the USB HID Device.....	162	9.4. UPDATING VIA GUI	190	13.3. MAXIMUM CABLE EXTENSIONS	221
7.19.11. Querying the Serial Number of the USB HID Device	162	9.5. COMMAND LINE INTERFACE (CLI)	193	13.3.1. F-series Endpoints.....	221
7.19.12. Querying the Device Class of the USB HID Device.....	162	9.5.1. How to Run	193	13.3.2. R-series Endpoint	221
7.19.13. Querying the Interface Classes of the USB HID Device	162	9.5.2. How to Use.....	193	13.4. INPUT/OUTPUT PORT NUMBERING	222
7.19.14. Enable/Disable Power Sending of the USB HID Port.....	163	9.6. CLI COMMANDS	193	13.4.1. F100 / R100 - TX Mode.....	222
7.19.15. Enable/Disable Suspending of the USB HID Port	163	9.6.1. Help	193	13.4.2. F100 / R100 - RX Mode.....	222
7.20. LW3 PROTOCOL COMMANDS - QUICK SUMMARY	164	9.6.2. LDU2 Version	194	13.4.3. F100 / R100 - TRX Mode.....	222
8. SWITCHABLE USB COMMAND PROTOCOL	171	9.6.3. Check For New LDU2 Version.....	194	13.4.4. F100 / R100 - RXMV Mode.....	223
8.1. INSTRUCTIONS FOR THE TERMINAL APPLICATION USAGE	172	9.6.4. Device Info	194	13.4.5. F110 / F111 / F120 / F121 / F130 - TX Mode	223
8.2. SETUP	172	9.6.5. Update.....	195	13.4.6. F110 / F111 / F120 / F121 / F130 - RX Mode	224
8.3. PROTOCOL DESCRIPTION	173	9.6.6. Restore	195	13.4.7. F110 / F111 / F120 / F121 / F130 - TRX Mode	224
8.3.1. Legend for the Commands	173	9.6.7. Package Options	196	13.4.8. F110 / F111 / F120 / F121 / F130 - RXMV Mode.....	225
8.4. NETWORK BROADCAST	173	9.6.8. Complex Examples.....	196	13.4.9. Control Port Numbering.....	225
8.4.1. Subnet Broadcast.....	173	9.6.9. Exit Codes.....	197	13.5. FACTORY DEFAULT SETTINGS	227
8.4.2. All Local Subnet Broadcast.....	173	9.7. IF THE UPDATE IS NOT SUCCESSFUL	197	13.5.1. UBEX-PRO20-HDMI-F100 / R100 series	227
8.4.3. Mismatched Network Configuration.....	173	10. TROUBLESHOOTING	198	13.5.2. UBEX-PRO20-HDMI-F110 / F111	228
8.5. GENERIC REPLIES	174	10.1. USE CASES	199	13.5.3. UBEX-PRO20-HDMI-F120 / F121	229
8.5.1. Acknowledge	174	10.2. HOW TO SPEED UP THE TROUBLESHOOTING PROCESS	201	13.5.4. UBEX-PRO20-HDMI-F130.....	230
8.5.2. Negative Acknowledge	174				

13.6. CONTENT OF BACKUP FILE.....	231
13.6.1. F100 / R100 - Transmitter Mode	231
13.6.2. F100 / R100 - Receiver Mode	231
13.6.3. F100 / R100 - Transceiver Mode	232
13.6.4. F100 / R100 - Multiviewer Mode	232
13.6.5. F110 / F111 - Transmitter Mode	233
13.6.6. F110 / F111 - Receiver Mode	233
13.6.7. F110 / F111 - Transceiver Mode	234
13.6.8. F110 / F111 - Multiviewer Mode	234
13.6.9. F120 / F121 - Transmitter Mode	235
13.6.10. F120 / F121 - Receiver Mode	235
13.6.11. F120 / F121 - Transceiver Mode	236
13.6.12. F120 / F121 - Multiviewer Mode	236
13.6.13. F130 - Transmitter Mode	237
13.6.14. F130 - Receiver Mode	237
13.6.15. F130 - Transceiver Mode	238
13.6.16. F130 - Multiviewer Mode	238
13.7. RELEASE NOTES OF THE FIRMWARE PACKAGES	239
13.7.1. Release Notes	239
13.7.2. Known Issues	243
13.8. RESOLUTIONS OF THE SCALER.....	244
13.9. FACTORY EDID LIST.....	245
13.10. MECHANICAL DRAWINGS	246
13.10.1. UBEX F-series Endpoint Devices	246
13.10.2. UBEX R-series Endpoint Devices.....	247
13.11. BANDWIDTH REQUIREMENTS OF THE RESOLUTIONS	248
13.11.1. Calculation Formula	248
13.11.2. Table of the Most Used Resolutions.....	249
13.12. CABLE WIRING GUIDE	251
13.12.1. Serial Ports	251
13.12.2. Audio Ports.....	251
13.13. QUICK LINK COLLECTION	252
13.14. HASHTAG KEYWORD LIST	255
13.15. FURTHER DOCUMENT INFORMATION	257
13.16. LIMITED WARRANTY STATEMENT	257

Applied SW/FW/HW Environment

All presented functions refer to the indicated products. The descriptions have been made while testing these functions in accordance with the indicated Hardware/Firmware/Software environment:

Item		Version
Lightware Device Controller (LDC) software		v2.20.0b3
Lightware Device Updater V2 (LDU2) software		v2.36.0b8
Firmware package	UBEX F-series endpoint devices	v3.5.5b8
	UBEX R-series endpoint devices	

Document Revision History

Rev.	Release date	Changes	Editor
v1.0	2018-06-12	Initial version	Tamas Forgacs
...			
v2.14	2025-03-21	Cosmetic corrections	Tamas Forgacs
v3	2026-02-10	New UM template applied	Tamas Forgacs

Contact Us

sales@lightware.com

+36 1 255 3800

support@lightware.com

+36 1 255 3810

Lightware Visual Engineering PLC.

Gizella 51-57, Budapest H-1143, Hungary

www.lightware.com

©2026 Lightware Visual Engineering. All rights reserved.
All trademarks mentioned are the property of their respective owners.
Specifications are subject to change without notice.

1

Introduction

Thank you for choosing Lightware's UBEX families extender. In the first chapter we would like to introduce the device, highlighting the most important features in the following sections:

▶ Description	11
▶ Box Contents	12
▶ Model Comparison	13
▶ Features	14
▶ Availability of the Endpoint Models	15
▶ Application Modes	16
▶ Typical Applications	16

1.1. Description

Lightware’s one of the most visionary development project is the UBEX (Ultra Bandwidth Extender) product family. UBEX is a fiber-optical, scaling AV-Over-IP system that allows uncompressed 4K UHD@60Hz 4:4:4 signal extension with latency-free multistreaming, designed to use in a 10G Ethernet network. UBEX operates with zero frame latency, provides seamless switching and lossless reproduction of source signals of up to 4K60Hz 4:4:4, without artifacts. Uncompressed 4K60Hz 4:4:4 data transmission, or visually lossless compression at higher data rates.

Full 4k HDMI 2.0
60Hz & 4:4:4 HIGH DEFINITION MULTIMEDIA INTERFACE

It has standard, 10 Gbps SFP+ optical modules installed, which are field exchangeable by the user. UBEX can transfer two video signals over a single 10G link with minimal compression, which requires half the router size compared to the needs of similar, 10G IP based architectures. With a 20G configuration, UBEX can transfer 4K@60Hz 4:4:4 over two links uncompressed. The maximum reachable distance is ranging between 400 m and 80 km, depending on the type of singlemode or multimode SFP+ optical modules installed in the device. The UBEX design also favors dual-screen applications, as a single UBEX device can handle 2x HDMI 2.0 video ports. For video signals that can be transferred within the 10G speed limit of a single optical fiber, a video signal redundancy feature is available employing the second optical fiber channel.

The R-type UBEX product variant is specifically designed to withstand the daily wear and tear impacts of dynamic, Rental&Staging type of applications. The devices share the features of the standard UBEX-PRO20-HDMI-F100 model, with additional features and changes in build and dimensions.

UBEX is available with numerous add-ons, providing audio breakaway signal management, K+M, IR, RS-232 and Gigabit Ethernet control.

The internal power source of UBEX has Medical (60601) and ITE (60950) grade classifications for maximum reliability.

Model Denomination

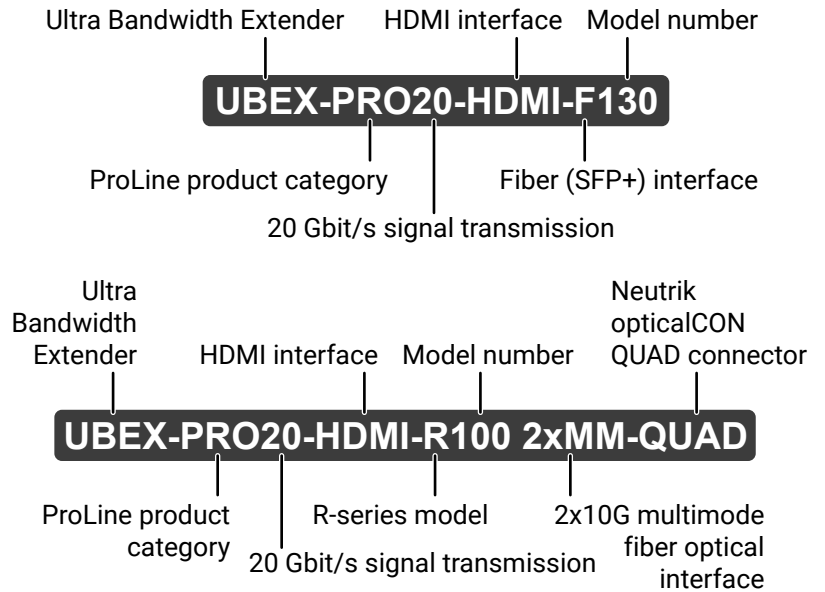

About the Serial Number

Lightware devices contain a label indicating the unique serial number of the product. The structure is the following:

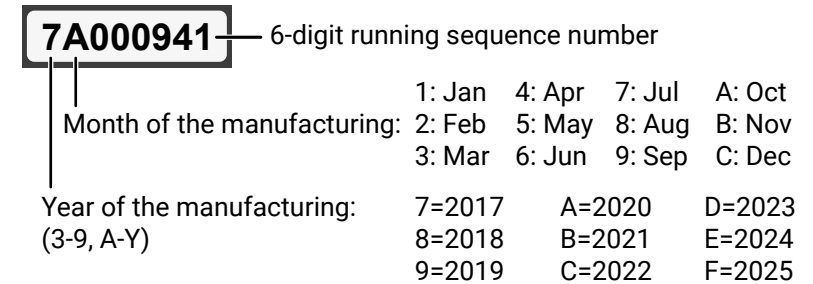



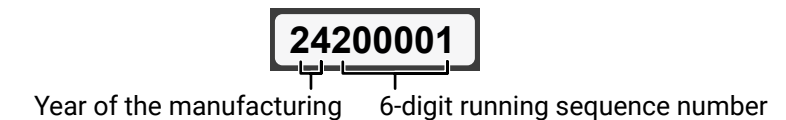

From 1st of October 2024, serial number format of Lightware devices is the following: the first two digits are of the year of manufacture, while the remaining digits make up the running sequence number.

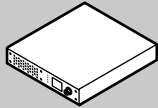
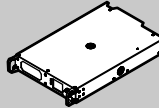
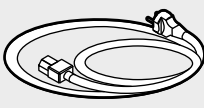
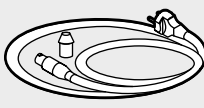

1.2. Box Contents

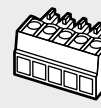

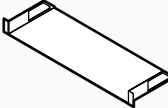
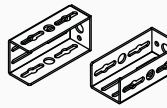
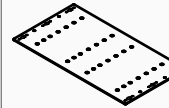
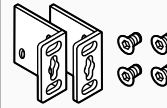
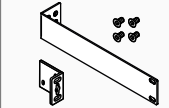













The following table describes all supplied and optional accessories of the UBEX endpoint devices by models. The optional (not-supplied) accessories can be purchased separately; please contact sales@lightware.com.

	Supplied devices		Supplied accessories					Optional accessories				
	 F-series endpoint device	 R-series endpoint device	 IEC power cable	 Power cable with Neutrik powerCON connector	 Phoenix® Combicon 3-pole connector	 Phoenix® Combicon 5-pole connector	 Safety & Warranty Info; Quick Start Guide	 1U high rack shelf	 Mounting bracket V2	 UD mounting plate F120	 Rack ears (2x) with M4x8 screws (4x) for two units	 Rack ears (2x) with M4x8 screws (4x) for one unit
UBEX-PRO20-HDMI-F100	✓	-	✓	-	-	-	✓	✓	✓	✓	-	-
UBEX-PRO20-HDMI-F110	✓	-	✓	-	✓	✓	✓	✓	✓	✓	-	-
UBEX-PRO20-HDMI-F111	✓	-	✓	-	✓	✓	✓	✓	✓	✓	-	-
UBEX-PRO20-HDMI-F120	✓	-	✓	-	✓	✓	✓	✓	✓	✓	-	-
UBEX-PRO20-HDMI-F121	✓	-	✓	-	✓	✓	✓	✓	✓	✓	-	-
UBEX-PRO20-HDMI-F130	✓	-	✓	-	✓	✓	✓	✓	✓	✓	-	-
UBEX-PRO20-HDMI-R100 2xMM-2xDUO	-	✓	-	✓	-	-	✓	-	-	-	✓	✓
UBEX-PRO20-HDMI-R100 2xSM-2xDUO	-	✓	-	✓	-	-	✓	-	-	-	✓	✓
UBEX-PRO20-HDMI-R100 2xMM-QUAD	-	✓	-	✓	-	-	✓	-	-	-	✓	✓
UBEX-PRO20-HDMI-R100 2xSM-QUAD	-	✓	-	✓	-	-	✓	-	-	-	✓	✓
UBEX-PRO20-HDMI-R100 2xSM-BiDi-DUO	-	✓	-	✓	-	-	✓	-	-	-	✓	✓

INFO: 10GbE singlemode/multimode SFP+ modules and 10 GbE SFP+ to RJ45 modules can be ordered together and even separately for the F-series endpoint devices. Endpoint & SFP+ module packages are tested together. For the details, please contact sales@lightware.com.

1.3. Model Comparison

The available UBEX endpoint models have different features depending on their design. The following table contains the most important differences between the models:

		Power connector		AV transmission interface				Video ports		Audio ports		Interface ports						
		IEC power 	Neutrik powerCON TRUE1 	SFP+ slots 	Multimode		Singlemode		HDMI inputs * 	HDMI outputs * 	Analog audio input 	Analog audio output 	Ethernet		Infra input and output 	RS-232 	USB K+M 	USB KVM and USB 2.0 extension 
					Neutrik opticalCON DUO 	Neutrik opticalCON QUAD 	Neutrik opticalCON DUO 	Neutrik opticalCON QUAD 					Standard RJ45 	Neutrik etherCON 				
F-series models	UBEX-PRO20-HDMI-F100	✓	-	✓	-	-	-	-	✓ (2x)	✓ (2x)	-	-	✓ (2x)	-	-	-	-	-
	UBEX-PRO20-HDMI-F110	✓	-	✓	-	-	-	-	✓ (2x)	✓ (2x)	✓	✓	✓ (3x)	-	✓	✓	-	-
	UBEX-PRO20-HDMI-F111	✓	-	✓	-	-	-	-	✓ (2x)	✓ (2x)	✓	✓	✓ (3x)	-	-	✓	-	-
	UBEX-PRO20-HDMI-F120	✓	-	✓	-	-	-	-	✓ (2x)	✓ (2x)	✓	✓	✓ (3x)	-	✓	✓	✓**	-
	UBEX-PRO20-HDMI-F121	✓	-	✓	-	-	-	-	✓ (2x)	✓ (2x)	✓	✓	✓ (3x)	-	-	✓	✓	-
	UBEX-PRO20-HDMI-F130	✓	-	✓	-	-	-	-	✓ (2x)	✓ (2x)	✓	✓	✓ (3x)	-	-	✓	-	✓
Rental (R-series) models	UBEX-PRO20-HDMI-R100 2xMM-2xDUO	-	✓	-	✓ (2x)	-	-	-	✓ (2x)	✓ (2x)	-	-	-	✓ (1x)	-	-	-	-
	UBEX-PRO20-HDMI-R100 2xMM-QUAD	-	✓	-	-	✓ (1x)	-	-	✓ (2x)	✓ (2x)	-	-	-	✓ (2x)	-	-	-	-
	UBEX-PRO20-HDMI-R100 2xSM-2xDUO	-	✓	-	-	-	✓ (2x)	-	✓ (2x)	✓ (2x)	-	-	-	✓ (1x)	-	-	-	-
	UBEX-PRO20-HDMI-R100 2xSM-QUAD	-	✓	-	-	-	-	✓ (1x)	✓ (2x)	✓ (2x)	-	-	-	✓ (2x)	-	-	-	-
	UBEX-PRO20-HDMI-R100 2xSM-BiDi-DUO	-	✓	-	-	-	✓ (1x)	-	✓ (2x)	✓ (2x)	-	-	-	✓ (2x)	-	-	-	-

* The HDMI input and output ports of the R-series endpoint models have **flange** mounting option.

** UBEX-PRO20-HDMI-F120 variant contains USB-B connector instead of USB-C for the host interface.

1.4. Features

For All UBEX Endpoint Models



Uncompressed 4K Support

Up to HDMI 2.0 4K 2160p@60Hz 4:4:4 video input or 4096x2160@60Hz resolution over a 20 Gigabit network with extra low latency.



Ethernet Based Extender

The UBEX system is Ethernet based, using 10 GbE, IGMPv2, and IPv4 protocols.



Pixel Accurate Reclocking

Each output has a clean, jitter free signal, eliminating signal instability and distortion caused by long cables or connector reflections.



Scaling the Output Image

Video scaling is the process of changing the size of a video frame in order to match the native resolution of a display sink. It involves converting the resolution to a higher or lower format, and also a change in aspect ratio; typically from 4:3 to 16:9.



HDCP 2.2 compliant

The UBEX extenders comply to the HDCP 2.2 standard. HDCP capability on the digital video inputs can be disabled when non-protected content is extended.



Frame Detector and Signal Analysis

The exact video and audio signal format can be determined such as timing, frequencies, scan mode, HDCP encryption, color range, color space and audio sample rate.



Changeable Operation Mode

UBEX endpoint devices can be configured as transmitter, receiver, or transceiver in few simple steps by the user anytime.



Multiviewer

The multiviewer operation mode of UBEX endpoints allows the extension of several streams to one single sink, where they can be variously ordered and grouped on a canvas. Multiviewer is a special operation mode like transmitter, receiver or transceiver, which can be activated in all UBEX endpoint models.



Seamless Switching (Clean Cut)

UBEX series extenders provide seamless switching (clean cut) technology, which is the capability to deliver consistent performance and reliability. The advantage of the technology is that various environments with different video sources and displays will not impact signal loss.

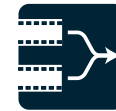

Multi Stream

UBEX endpoint devices are able to simultaneously transmit two video streams with embedded audio via the SFP+ interface.

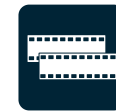

Stream Copy

UBEX endpoint devices are able to copy the stream of the HDMI out 1 to the HDMI out 2 port. This is the COPY function. The function is available in receiver and transceiver operation modes.



Color Space Conversion

Color space of the output video can be changed based on the type of the display device.



Deep Color Support

It is possible to transmit the highest quality 36-bit video streams and HDR contents for the perfect color reproduction.



Custom Resolutions

Endpoint devices support any type of display device with custom resolutions to best fit the user's application.



Wide Range of Audio Format Support

Endpoint devices support the most of known audio signal formats, including HBR audio like Dolby TrueHD, Dolby Atmos and DTS-HD Master Audio 7.1.



Local Video Output

User can attach a local monitor to observe the video signal sent through the SFP+ ports. The resolution and clock frequency are the same with the HDMI inputs, no internal scaling or conversion is applied. The function is available in transmitter and transceiver operation modes.



Local Video Input

User can attach local source devices to the input ports of the UBEX receiver. The streams with the received resolution and clock frequency are transmitted on the output ports and no internal scaling or color conversion is applied. The function is available in receiver operation mode.



Modular SFP+ Interface

UBEX series extenders use standard, certificated 10 Gbps SFP+ optical modules, which are plug and play, so they are swappable by the user.



Silent Operation

The optimized fan operation allows installing the endpoint device to places where minimum sound emission is required.

**Dark Mode**

Rental application requires this function, which keeps the LCD screen and the LEDs unlit to hide the device during the event.

**Open API**

Open-source API technology at the core makes these Lightware products easy to integrate into third-party systems. Every bit of data in Lightware systems is openly available for higher level management and monitoring systems.

Only for UBEX-PRO20-HDMI-F110, -F111, -F120, -F121 and -F130 Models**Audio Embedder and De-embedder Function**

The analog audio can be embedded to HDMI outputs and embedded audio can be routed to the analog audio output in transmitter, receiver, and transceiver operation modes as well.

**RS-232 Interface**

AV systems can also contain serial port for controlled devices. Serial port supports any unit that works with standard RS-232.

Only for UBEX-PRO20-HDMI-F110 and -F120 Models**Infrared Interface**

Infrared (IR) is a wireless technology used for device communication over short ranges. Infrared is commonly used for remote control based applications. Third-party control systems may send IR control commands to endpoints, turning them on and off or switching their inputs.

Only for UBEX-PRO20-HDMI-F120 and -F121 Models**USB K+M Extension**

K+M extension for USB HID (Human Interface Devices, e.g. keyboard, mouse, presenter).

Only for UBEX-PRO20-HDMI-F130 Model**USB KVM and USB 2.0 Extension Powered by Icron**

KVM extension with USB 2.0 support for USB HID (Human Interface Devices, e.g. keyboard, mouse, presenter, webcam, etc).

Only for the UBEX-PRO20-HDMI-R100 Series Models**Mounting Threads**

Mounting threads on top and one side for the R-series models to conform strict installation safety regulations.

1.5. Availability of the Endpoint Models

The following table shows the production life cycle status of the UBEX endpoint models.

Model	Status	Equivalent Active Model
UBEX-PRO20-HDMI-F100	Active	-
UBEX-PRO20-HDMI-F110	Will be discontinued	UBEX-PRO20-HDMI-F111
UBEX-PRO20-HDMI-F111	Active	-
UBEX-PRO20-HDMI-F120	Will be discontinued	UBEX-PRO20-HDMI-F121
UBEX-PRO20-HDMI-F121	Active	-
UBEX-PRO20-HDMI-F130	Active	-
UBEX-PRO20-HDMI-R100 2xMM-2xDUO	Active	-
UBEX-PRO20-HDMI-R100 2xMM-QUAD	Active	-
UBEX-PRO20-HDMI-R100 2xSM-2xDUO	Active	-
UBEX-PRO20-HDMI-R100 2xSM-QUAD	Active	-
UBEX-PRO20-HDMI-R100 2xSM-BiDi-DUO	Active	-

See the differences about the UBEX endpoint variants in the [Model Comparison](#) section.

1.6. Application Modes

UBEX extender system has two main application modes: *#applicationmode*

- **EXTENDER MODE** - Point-to-point connection between a transmitter and a receiver, or between two transceiver endpoint devices. **This document is about the Extender mode only.** *#extendermode*



- **MATRIX MODE** - Virtual AV matrix with more transmitters, receivers, transceivers, and a Matrix Management Unit (MMU) that controls the AV network. The user manual of the UBEX Matrix mode can be downloaded from the following link: *#matrixmode*

<https://go.lightware.com/ubex-pum>

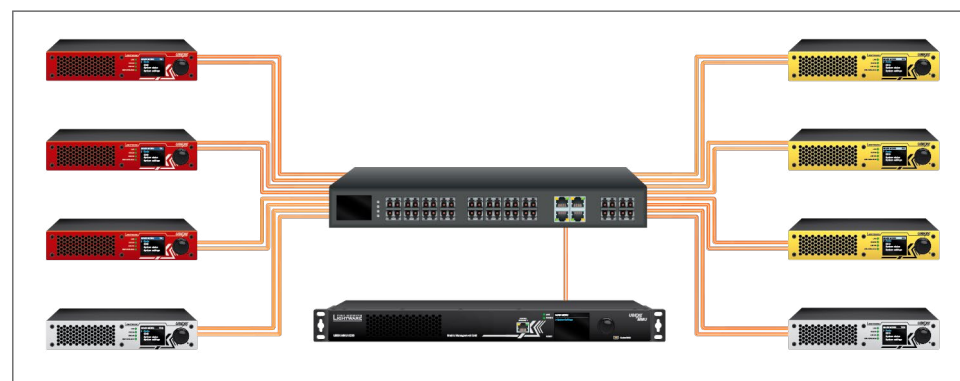

INFO: The Extender or Matrix mode is set automatically in the endpoint device. If the device detects direct connection with another endpoint device at the other side of the connection, the mode is set to Extender mode; if the MMU connects to the device, the mode is set to Matrix mode.

The two modes bring different functionality and control methods for the endpoint and the MMU devices. The following settings are available in the MMU only in case the Matrix mode:

- Operation mode setting (TX / RX / TRX / RXMV configuration for the endpoints)
- All network-related settings, e.g. DHCP setting, static IP address, etc.
- All HDMI port settings for the inputs and outputs
- EDID settings
- Reloading factory defaults
- Centralized firmware update method for the endpoint devices

ATTENTION: Switching between the Extender and Matrix mode changes the LCD menu structure and the LW3 command protocol tree of the endpoint device. It happens because of the control settings listed above transfer between the endpoints and the MMU.

1.7. Typical Applications

1.7.1. Transmitter-Receiver Pair

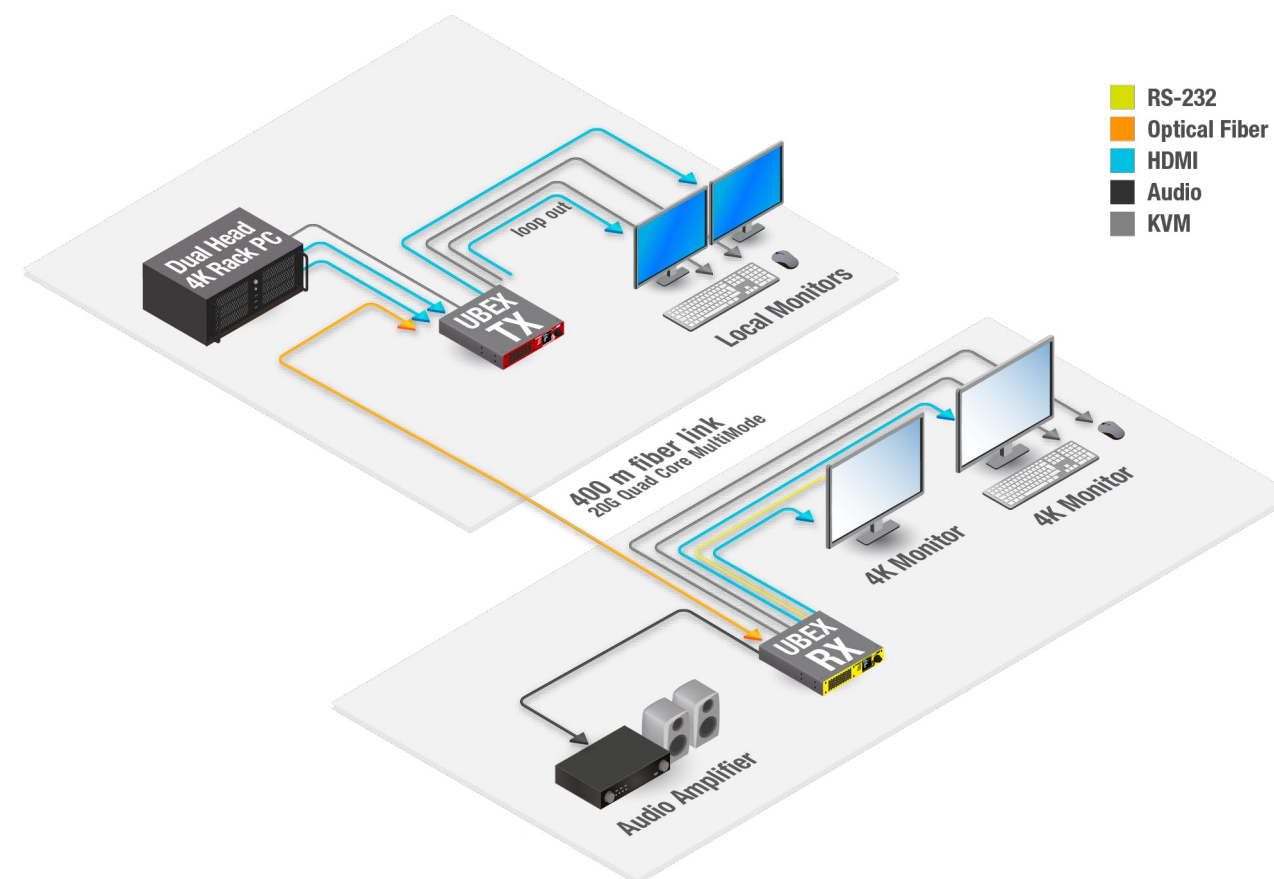

Application diagram of Extender mode - TX-RX pair

Description

The UBEX transmitter (UBEX-PRO20-HDMI-F121, TX operation mode) has two video source devices (Dual head 4K rack PC) and an audio source device (media player). The streams can be checked on the local monitors connected to the transmitter. The PC also connects to the transmitter over an USB cable to control the AV system.

The UBEX receiver (UBEX-PRO20-HDMI-F121, RX operation mode) has two video sink devices (two 4K monitors), an analog audio sink device (audio amplifier) and USB HID devices (a keyboard and a mouse).

One of the 4K monitor is controlled via RS-232 interface by the UBEX receiver.

The UBEX extender pair is able to transmit a 4K UHD 60 Hz 4:4:4 and a 4K UHD 30 Hz 4:4:4, or two 4K 60 Hz 4:2:2 streams.

1.7.2. Transceiver-Transceiver Pair

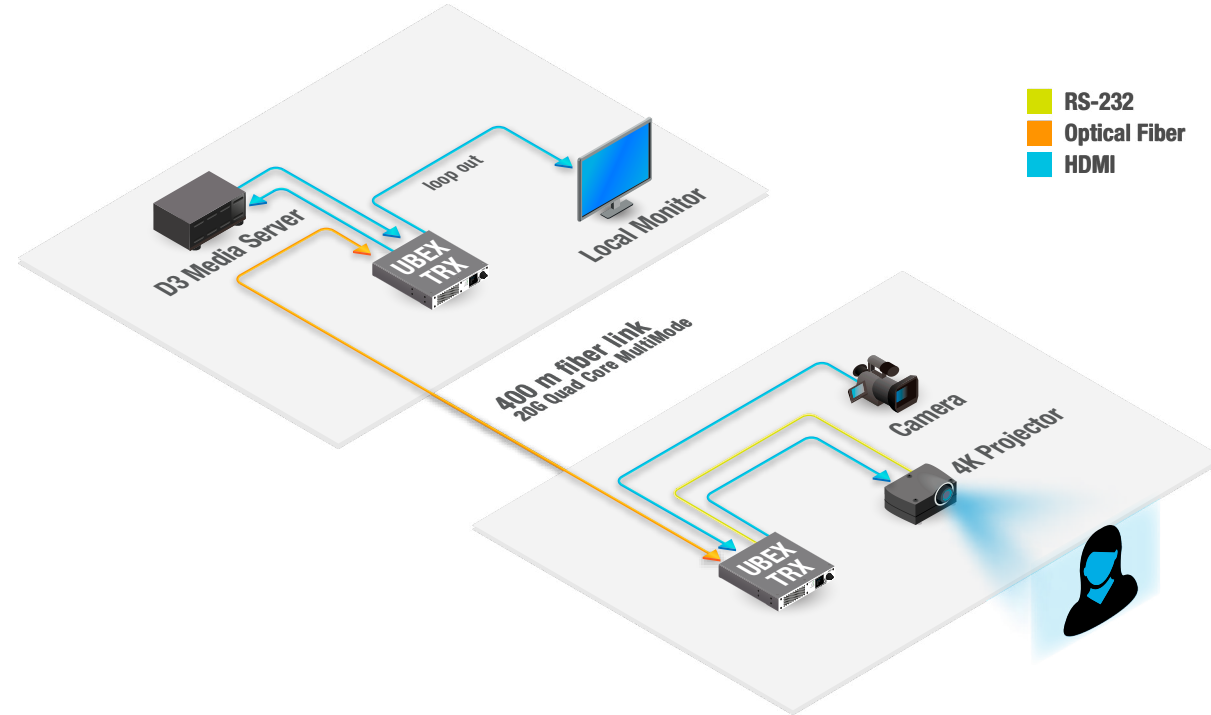

Application diagram of Extender mode - TRX-TRX pair

Description

Two UBEX transceivers are connected each other via 400 m fiber optical cables.

The UBEX-PRO20-HDMI-F100 transceiver connects to a D3 media server, which is the source and the sink device together. The incoming stream can be checked locally on the local monitor.

The UBEX-PRO20-HDMI-F111 transceiver has a source device (camera) and a sink device (4K projector). The projector is controlled via RS-232 interface by the extender.

Thanks to the 20G full-duplex SFP+ interface, the transceiver has no bandwidth limitation on the input nor on the output sides. The device is able to receive and transmit 2x 4K60 Hz 4:4:4 24 bit streams.

1.7.3. Multiviewer Application Diagram

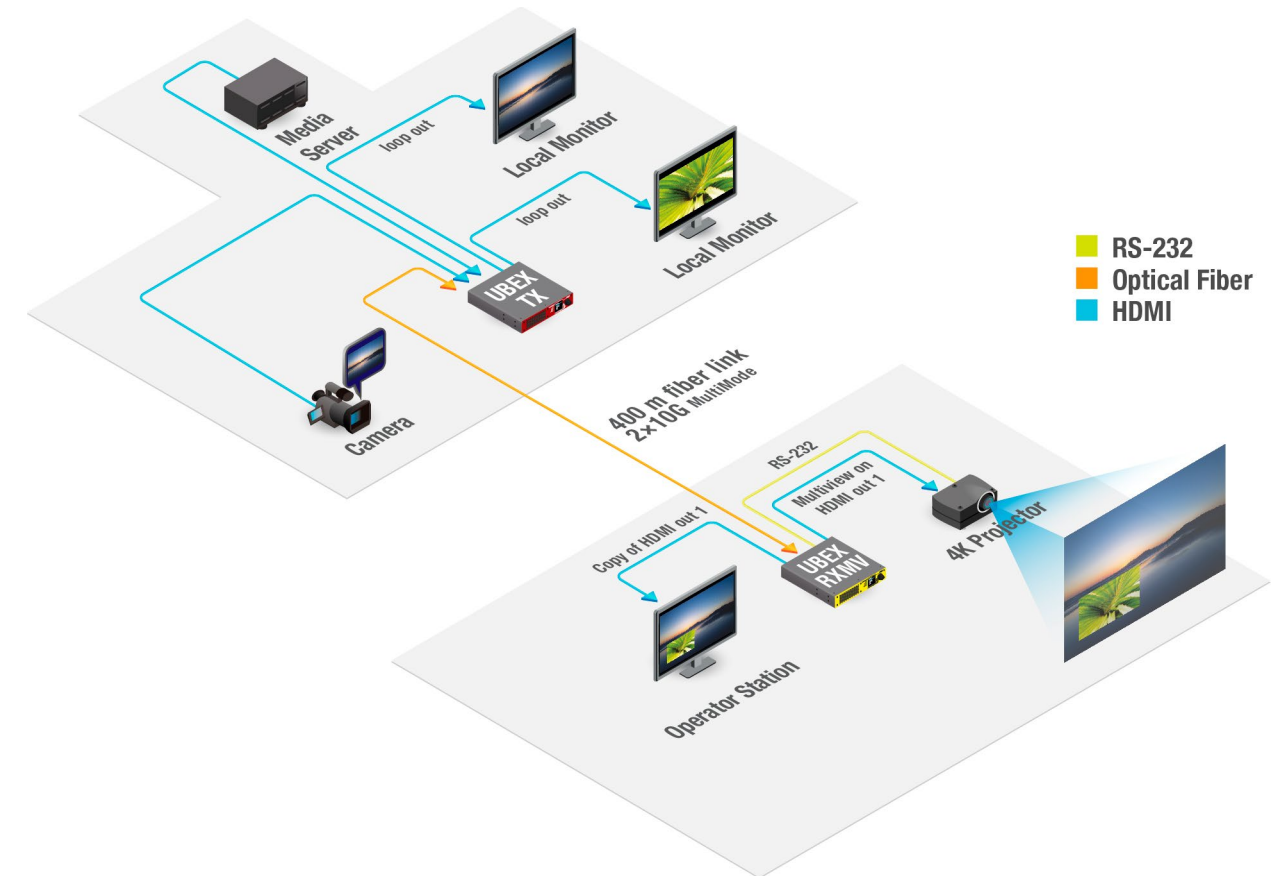

Application diagram of Extender mode - Transmitter-Multiviewer pair

Description

The UBEX transmitter (UBEX-PRO20-HDMI-F100, TX operation mode) has two video source devices (a media server and a camera). The streams can be checked on the local monitors connected to the transmitter.

The UBEX multiviewer (UBEX-PRO20-HDMI-F111, RXMV operation mode) has two video sink devices (a 4K projector and a 4K monitor). The HDMI out 1 port transmits the multiviewer stream with the two source streams, the HDMI out 2 is set to the copy of the HDMI out 1 port in the Source MUX settings.

The 4K projector is controlled via RS-232 interface by the UBEX multiviewer.

The UBEX extender pair is able to transmit a 4K UHD 60 Hz 4:4:4 and a 4K UHD 30 Hz 4:4:4, or two 4K 60 Hz 4:2:2 streams, see more details about it in the [Bandwidth Requirements of the Resolutions](#) section.

See more details about the multiviewer feature in the [Multiviewer Mode](#) section.

2

Product Overview

The following sections are about the physical structure of the device, input/ output ports and connectors; software and hardware capabilities:

- ▶ Front and Rear View - F-series Endpoint Devices **19**
- ▶ Front and Rear View - R-series Endpoint Devices **23**

2.1. Front and Rear View - F-series Endpoint Devices

2.1.1. Front View



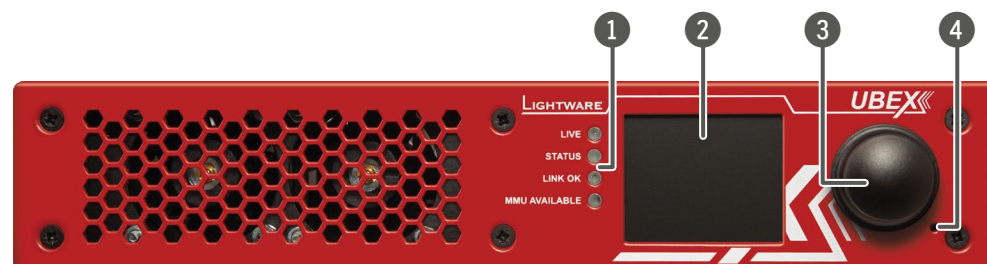







All Models



- 1 Status LEDs** The LEDs give immediate feedback about the current status of the endpoint device. See the details about the operation of the LEDs in the [Status LEDs](#) section (on the right side).
- 2 LCD screen** LCD screen showing the most important settings and parameters in the front panel menu. The available settings and information depends on the current application mode. See the details in the [Front Panel LCD Menu Operations](#) chapter.
- 3 Jog dial control knob** Easy setting and menu navigation by the jog dial control. Keep dialing and clicking while getting feedback on the LCD.
The operation of the jog dial control knob can be disabled by the control lock feature. The function can be enabled using the following methods:

 - **Lightware Device Controller (LDC) software** - see the details in the [Front Panel Tab](#) section;
 - **LW3 protocol command** - see the details in the [Control Lock](#) section.
- 4 Reset button** Reboots the device (the same as disconnecting from the power source and reconnecting again).

Status LEDs

LIVE		Transmitter / Receiver / Transceiver
	blinking	The device is powered and ready to use.
	off	The device is not powered or out of operation.
STATUS		Transmitter / Receiver / Transceiver
	on	All measured temperature and voltage values are within the limits.
	blinking	Measured temperature or voltage value is out of the limits.
	off	The device is not powered or out of operation.
LINK OK		Transmitter / Receiver / Transceiver
	on	The connection is established on the fiber optical links and the Link Aggregation is working.
	blinking	The connection is established on the fiber optical links and LACP detection period is active.
	off	No connection is established on one of the fiber optical links.
MMU AVAILABLE		Transmitter / Receiver / Transceiver
	on	Matrix mode is active; the communication is live between the endpoint and the Matrix Management Unit (MMU).
	blinking	Matrix mode is active; no communication between the endpoint and the MMU.
	off	Extender mode is active; no communication between the endpoint and the MMU.

Dark Mode

Rental application requires this function, which keeps the LCD screen and the LEDs unlit to hide the device during the event. The function can be enabled via the following methods:

- **Front panel LCD menu** - see the details in the [Front Panel](#) section;
- **Lightware Device Controller (LDC) software / Built-in website** - see the details in the [Front Panel Tab](#) section;
- **LW3 protocol command** - see the details in the [Dark Mode Setting](#) section.

2.1.2. Rear View - F100 / F111 / F121 Models

UBEX-PRO20-HDMI-F100

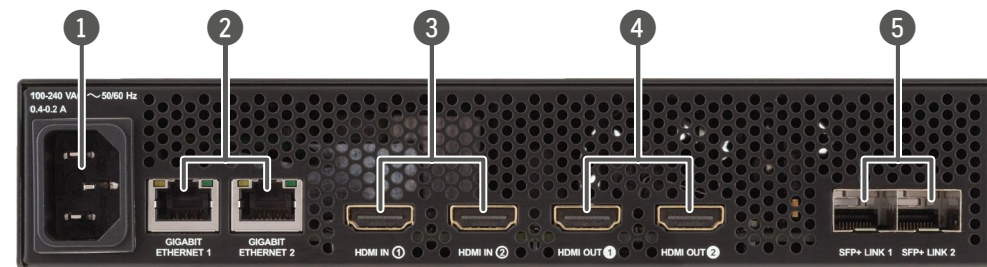

UBEX-PRO20-HDMI-F111

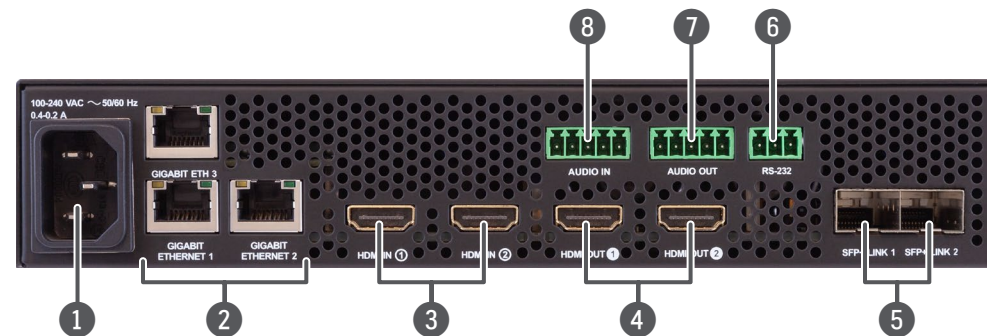

UBEX-PRO20-HDMI-F121

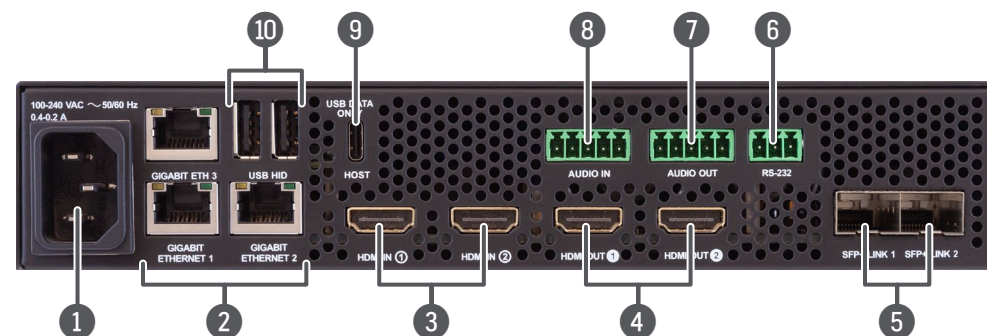

- 1 **AC connector** Standard IEC connector accepting 100-240 V, 50 or 60 Hz. See more details about it in the [AC Power Connection](#) section.

- 2 **Ethernet connectors** Standard locking RJ45 connectors for 1 Gbps Ethernet connections to control the device, for user Ethernet access, and firmware update purpose. See the details about the cable wiring in the [Ethernet Connectors](#) section and the concept of the operation in the [Ethernet Control Interface](#) section.
- 3 **HDMI input ports** HDMI input ports with HDMI 2.0 support for the source devices. When the device is configured as a receiver, the ports operate as local HDMI inputs. The HDMI in 1 port cannot accept AV signal when the device is configured as transceiver. See more details about the HDMI interface in the [Video Interface](#) section.
- 4 **HDMI output ports** HDMI output ports with HDMI 2.0 support for sink devices. When the device is configured as transmitter, the both ports operate as local HDMI outputs. When the device is configured as transceiver, the HDMI out 2 port operates as a local HDMI output. The HDMI out 2 port is able to copy the signal of the HDMI in 1 port when the device is configured as receiver or transceiver. See more details about the HDMI interface in the [Video Interface](#) section.
- 5 **SFP+ port slots** Optical port slots for 2x 10 GbE SFP+ modules or 2x 10 GbE DAC cables. Ports can be used for either singlemode or multimode fiber optical connections. See more details about the SFP+ interface in the [SFP+ Interface](#) section.
- 6 **RS-232 connector** 3-pole Phoenix connector for serial communication. See more details about the pin assignment in the [RS-232 Connector](#) section, about the cable wiring in the [Serial Ports](#) section, and the concept of the operation in the [Serial Interface](#) section.
- 7 **Analog audio output port** 5-pole Phoenix connector for balanced analog audio output. The port is available in all operation modes (TX/RX/TRX). See more details about the pin assignment in the [Symmetrical Analog Stereo Audio Connector](#) section, about the cable wiring in the [Audio Ports](#) section, and about the analog audio interface in the [Audio Interface](#) section.
- 8 **Analog audio input port** 5-pole Phoenix connector for balanced analog audio input. The port is available in all operation modes (TX/RX/TRX). See more details about the pin assignment in the [Symmetrical Analog Stereo Audio Connector](#) section, about the cable wiring in the [Audio Ports](#) section, and about the analog audio interface in the [Audio Interface](#) section.
- 9 **Host port** USB-C connection between the extender and the host computer. The port receives **USB data only**, no AV signal transmission is accepted. It **supports USB 2.0** standard only. See more details about the K+M feature in the [USB K+M Interface \(F120 and F121 Models\)](#) section.
- 10 **USB HID ports** Two USB-A ports for connecting HID devices (keyboard, mouse, pointer, etc) for USB K+M extension. The port is available in all operation modes (TX/RX/TRX). See more details about the K+M feature in the [USB K+M Interface \(F120 and F121 Models\)](#) section.

2.1.3. Rear View - F130 Model

UBEX-PRO20-HDMI-F130

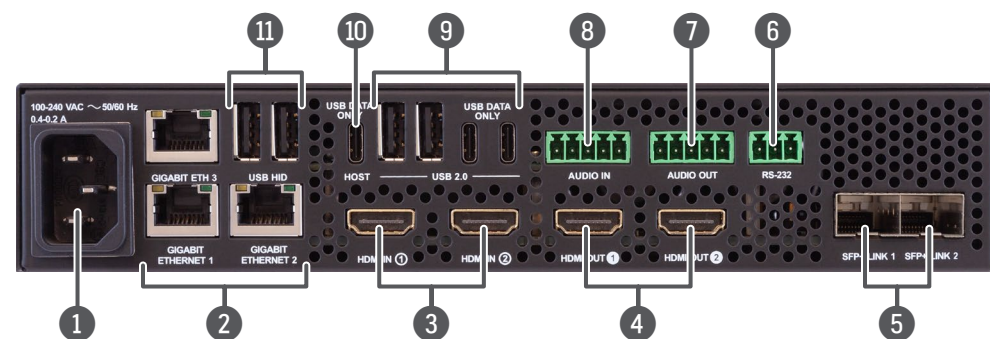

- 1 AC connector** Standard IEC connector accepting 100-240 V, 50 or 60 Hz. See more details about it in the [AC Power Connection](#) section.
- 2 Ethernet connectors** Standard locking RJ45 connectors for 1 Gbps Ethernet connections to control the device, for user Ethernet access, and firmware update purpose. See the details about the cable wiring in the [Ethernet Connectors](#) section and the concept of the operation in the [Ethernet Control Interface](#) section.
- 3 HDMI input ports** HDMI input ports with HDMI 2.0 support for the source devices. When the device is configured as a receiver, the ports operate as local HDMI inputs. The HDMI in 1 port cannot accept AV signal when the device is configured as transceiver. See more details about the HDMI interface in the [Video Interface](#) section.
- 4 HDMI output ports** HDMI output ports with HDMI 2.0 support for sink devices. When the device is configured as transmitter, the both ports operate as local HDMI outputs. When the device is configured as transceiver, the HDMI out 2 port operates as a local HDMI output. The HDMI out 2 port is able to copy the signal of the HDMI in 1 port when the device is configured as receiver or transceiver. See more details about the HDMI interface in the [Video Interface](#) section.
- 5 SFP+ port slots** Optical port slots for 2x 10 GbE SFP+ modules or 2x 10 GbE DAC cables. Ports can be used for either singlemode or multimode fiber optical connections. See more details about the SFP+ interface in the [SFP+ Interface](#) section.
- 6 RS-232 connector** 3-pole Phoenix connector for serial communication. See more details about the pin assignment in the [RS-232 Connector](#) section, about the cable wiring in the [Serial Ports](#) section, and the concept of the operation in the [Serial Interface](#) section.

- 7 Analog audio output port** 5-pole Phoenix connector for balanced analog audio output. The port is available in all operation modes (TX/RX/TRX). See more details about the pin assignment in the [Symmetrical Analog Stereo Audio Connector](#) section, about the cable wiring in the [Audio Ports](#) section, and about the analog audio interface in the [Audio Interface](#) section.
- 8 Analog audio input port** 5-pole Phoenix connector for balanced analog audio input. The port is available in all operation modes (TX/RX/TRX). See more details about the pin assignment in the [Symmetrical Analog Stereo Audio Connector](#) section, about the cable wiring in the [Audio Ports](#) section, and about the analog audio interface in the [Audio Interface](#) section.
- 9 USB 2.0 ports** USB-A connectors with USB 2.0 support for various types of USB devices (e.g. webcam, microphone, external storage, etc). The signal is transmitted to the connected extender over the SFP+ interface. See more details about the KVM feature in the [USB KVM / USB 2.0 Interface \(F130 Model\)](#) section.
- 10 Host port** USB-C connection between the extender and the host computer. The port receives **USB data only**, no AV signal transmission is accepted. It **supports USB 2.0** standard only. See more details about the K+M feature in the [USB KVM / USB 2.0 Interface \(F130 Model\)](#) section.
- 11 USB HID ports** USB KVM ports for HID-compatible devices (preferably keyboard and mouse). The signal is transmitted to the receiver over the SFP+ interface. See more details about the K+M feature in the [USB KVM / USB 2.0 Interface \(F130 Model\)](#) section.

2.1.4. Rear View - F110 / F120 Models

UBEX-PRO20-HDMI-F110

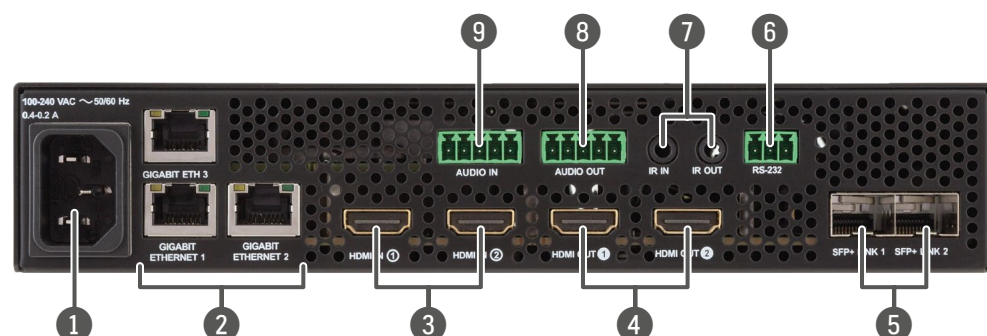

UBEX-PRO20-HDMI-F120

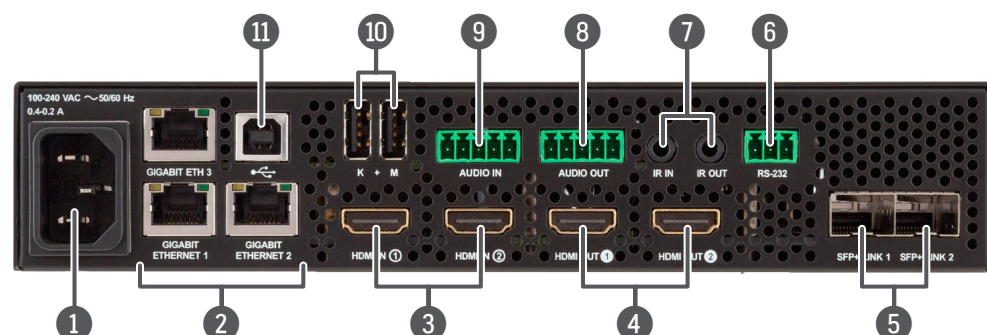

- ① **AC connector** Standard IEC connector accepting 100-240 V, 50 or 60 Hz. See more details about it in the [AC Power Connection](#) section.
- ② **Ethernet connectors** Standard locking RJ45 connectors for 1 Gbps Ethernet connections to control the device, for user Ethernet access, and firmware update purpose. See the details about the cable wiring in the [Ethernet Connectors](#) section and the concept of the operation in the [Ethernet Control Interface](#) section.
- ③ **HDMI input ports** HDMI input ports with HDMI 2.0 support for the source devices. When the device is configured as a receiver, the ports operate as local HDMI inputs. The HDMI in 1 port cannot accept AV signal when the device is configured as transceiver. See more details about the HDMI interface in the [Video Interface](#) section.

- ④ **HDMI output ports** HDMI output ports with HDMI 2.0 support for sink devices. When the device is configured as transmitter, the both ports operate as local HDMI outputs. When the device is configured as transceiver, the HDMI out 2 port operates as a local HDMI output. The HDMI out 2 port is able to copy the signal of the HDMI in 1 port when the device is configured as receiver or transceiver. See more details about the HDMI interface in the [Video Interface](#) section.
- ⑤ **SFP+ port slots** Optical port slots for 2x 10 GbE SFP+ modules or 2x 10 GbE DAC cables. Ports can be used for either singlemode or multimode fiber optical connections. See more details about the SFP+ interface in the [SFP+ Interface](#) section.
- ⑥ **RS-232 connector** 3-pole Phoenix connector for serial communication. See more details about the pin assignment in the [RS-232 Connector](#) section, about the cable wiring in the [Serial Ports](#) section, and the concept of the operation in the [Serial Interface](#) section.
- ⑦ **Infrared connectors** 3-pole TRS connector, also known as 3.5 mm (1/8") jack plug for optional IR detector (IR IN) and emitter (IR OUT) connection. See more details about the pin assignment in the [IR Connector](#) section, and about the concept of the operation in the [Infrared Interface](#) section.
- ⑧ **Analog audio output port** 5-pole Phoenix connector for balanced analog audio output. The port is available in all operation modes (TX/RX/TRX). See more details about the pin assignment in the [Symmetrical Analog Stereo Audio Connector](#) section, about the cable wiring in the [Audio Ports](#) section, and about the analog audio interface in the [Audio Interface](#) section.
- ⑨ **Analog audio input port** 5-pole Phoenix connector for balanced analog audio input. The port is available in all operation modes (TX/RX/TRX). See more details about the pin assignment in the [Symmetrical Analog Stereo Audio Connector](#) section, about the cable wiring in the [Audio Ports](#) section, and about the analog audio interface in the [Audio Interface](#) section.
- ⑩ **USB-A ports** Two USB-A ports for connecting HID devices (keyboard, mouse, pointer, etc) for USB K+M extension. The port is available in all operation modes (TX/RX/TRX). See more details about the K+M feature in the [USB K+M Interface \(F120 and F121 Models\)](#) section.
- ⑪ **USB-B port** USB-B port for connecting the host device (e.g. computer) for USB K+M extension. The port is available in all operation modes (TX/RX/TRX). See more details about the K+M feature in the [USB K+M Interface \(F120 and F121 Models\)](#) section.

2.2. Front and Rear View - R-series Endpoint Devices

2.2.1. Front View

All Models



- 1 Mounting ears** Durable mounting ears on both sides of the device for the easy mounting in the case of rental or staging application. The ears serve more purposes, see the details in the [Mounting Options - R-series Endpoint Devices](#) section.
- 2 Status LEDs** The LEDs give immediate feedback about the current status of the endpoint device. See the details about the operation of the LEDs in the [Status LEDs](#) section (on the right side).
- 3 LCD screen** LCD screen showing the most important settings and parameters in the front panel menu. The available settings and information depends on the current application mode. See the details in the [Front Panel LCD Menu Operations](#) chapter.
- 4 Jog dial control knob** Easy setting and menu navigation by the jog dial control. Keep dialing and clicking while getting feedback on the LCD.
The operation of the jog dial control knob can be disabled by the control lock feature. The function can be enabled using the following methods:

 - **Lightware Device Controller (LDC) software** - see the details in the [Front Panel Tab](#) section;
 - **LW3 protocol command** - see the details in the [Control Lock](#) section.
- 5 Reset button** Reboots the device (the same as disconnecting from the power source and reconnecting again).

Status LEDs

LIVE		Transmitter / Receiver / Transceiver
	blinking	The device is powered and ready to use.
	off	The device is not powered or out of operation.
STATUS		Transmitter / Receiver / Transceiver
	on	All measured temperature and voltage values are within the limits.
	blinking	Measured temperature or voltage value is out of the limits.
	off	The device is not powered or out of operation.
LINK OK		Transmitter / Receiver / Transceiver
	on	The connection is established on the fiber optical links and the Link Aggregation is working.
	blinking	The connection is established on the fiber optical links and LACP detection period is active.
	off	No connection is established on one of the fiber optical links.
MMU AVAILABLE		Transmitter / Receiver / Transceiver
	on	Matrix mode is active; the communication is live between the endpoint and the Matrix Management Unit (MMU).
	blinking	Matrix mode is active; no communication between the endpoint and the MMU.
	off	Extender mode is active; no communication between the endpoint and the MMU.

Dark Mode

Rental application requires this function, which keeps the LCD screen and the LEDs unlit to hide the device during the event. The function can be enabled via the following methods:

- **Front panel LCD menu** - see the details in the [Front Panel](#) section;
- **Lightware Device Controller (LDC) software / Built-in website** - see the details in the [Front Panel Tab](#) section;
- **LW3 protocol command** - see the details in the [Dark Mode Setting](#) section.

2.2.2. Rear View

UBEX-PRO20-HDMI-R100 2xMM-QUAD and 2xSM-QUAD

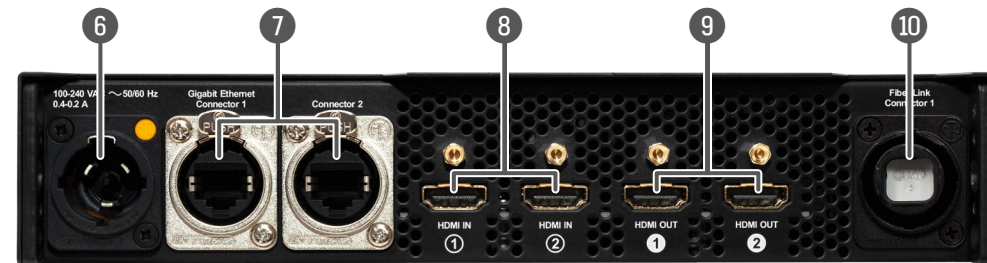

UBEX-PRO20-HDMI-R100 2xSM-BiDi-DUO

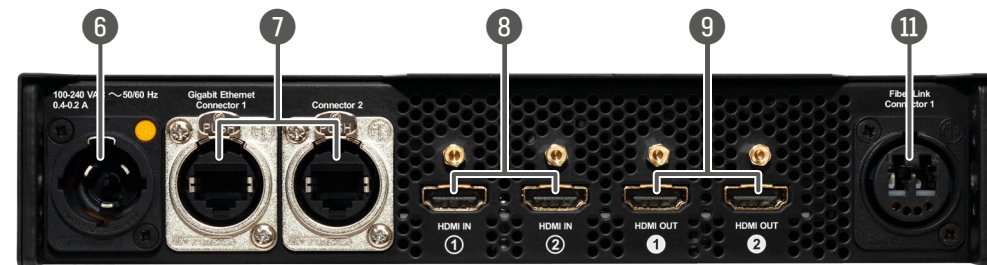

UBEX-PRO20-HDMI-R100 2xMM-2xDUO and 2xSM-2xDUO

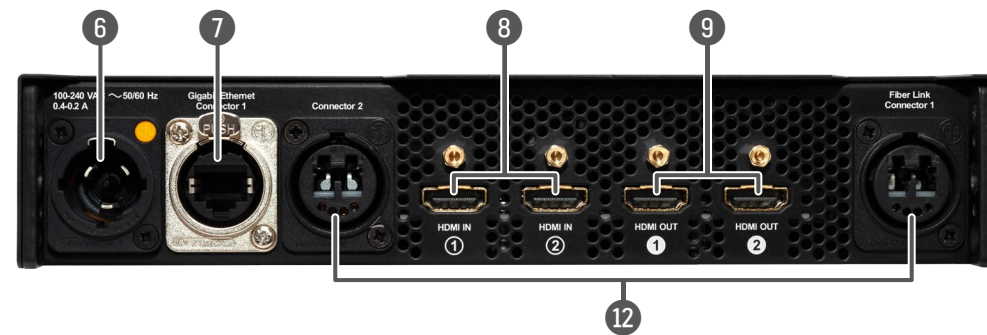

- 6 Neutrik powerCON AC connector** Neutrik powerCON TRUE1 NAC3MPX-WOT connector accepting 100-240 V, 50 or 60 Hz. See more details about it in the [AC Power Connection](#) section.
- 7 Neutrik etherCON Ethernet connectors** Neutrik etherCON NE8FDV-YK locking RJ45 connectors for 1 Gbps Ethernet connections to control the device, for user Ethernet access, and firmware update purpose. See the details about the cable wiring in the [Ethernet Connectors](#) section and the concept of the operation in the [Ethernet Control Interface](#) section.
- 8 HDMI input ports with flange** HDMI input ports with HDMI 2.0 support for the source devices. When the device is configured as a receiver, the ports operate as local HDMI inputs. The HDMI in 1 port cannot accept AV signal when the device is configured as transceiver. See more details about the HDMI interface in the [Video Interface](#) section.
- 9 HDMI output ports with flange** HDMI output ports with HDMI 2.0 support for sink devices. When the device is configured as transmitter, the both ports operate as local HDMI outputs. When the device is configured as transceiver, the HDMI out 2 port operates as a local HDMI output. The HDMI out 2 port is able to copy the signal of the HDMI in 1 port when the device is configured as receiver or transceiver. See more details about the HDMI interface in the [Video Interface](#) section.
- 10 Neutrik opticalCON QUAD optical connector** Neutrik opticalCON QUAD NO4FDW-A singlemode or multimode fiber optical connector for AV signal transmission.
- **2xMM-QUAD**: supports **multimode** cable connection.
 - **2xSM-QUAD**: supports **singlemode** cable connection.
- See more details about it in the [Neutrik opticalCON Connectors](#) section.
- 11 Neutrik opticalCON DUO BiDi optical connector** Neutrik opticalCON DUO NO2-4FDW-A **singlemode** fiber optical connector with BiDi support for AV signal transmission. See more details about it in the [Neutrik opticalCON Connectors](#) section.
- The connector does not support the Neutrik opticalCON crossed fiber wiring (A-A; B-B) cable. Please use standard (A-B) cable only.**
- 12 Neutrik opticalCON DUO optical connector** 2x Neutrik opticalCON DUO NO2-4FDW-A singlemode or multimode fiber optical connectors for AV signal transmission.
- **2xMM-2xDUO**: supports **multimode** cable connection.
 - **2xSM-2xDUO**: supports **singlemode** cable connection.
- See more details about it in the [Neutrik opticalCON Connectors](#) section.

See more details about the fiber optical connectors in the [Neutrik opticalCON Connectors](#) section and about the connection possibilities / connector pin layouts in the [Connection between F-series and R-series Endpoints](#) section.

3

Front Panel LCD Menu Operations

This chapter is about the operating of the device, describing the functions that are available by the front panel controls:

▶ The Tree Structure of the LCD Menu	26
▶ Introduction	27
▶ Home Screen	27
▶ Ports Menu - Transmitter Operation Mode	28
▶ Ports Menu - Receiver Operation Mode	29
▶ Ports Menu - Transceiver Operation Mode	30
▶ Ports Menu - Multiviewer Operation Mode	32
▶ EDID Menu	33
▶ System Status Menu	34
▶ KM Menu	34
▶ System Settings Menu	35

3.1. The Tree Structure of the LCD Menu

The tree structure of the transmitter (TX) operation mode

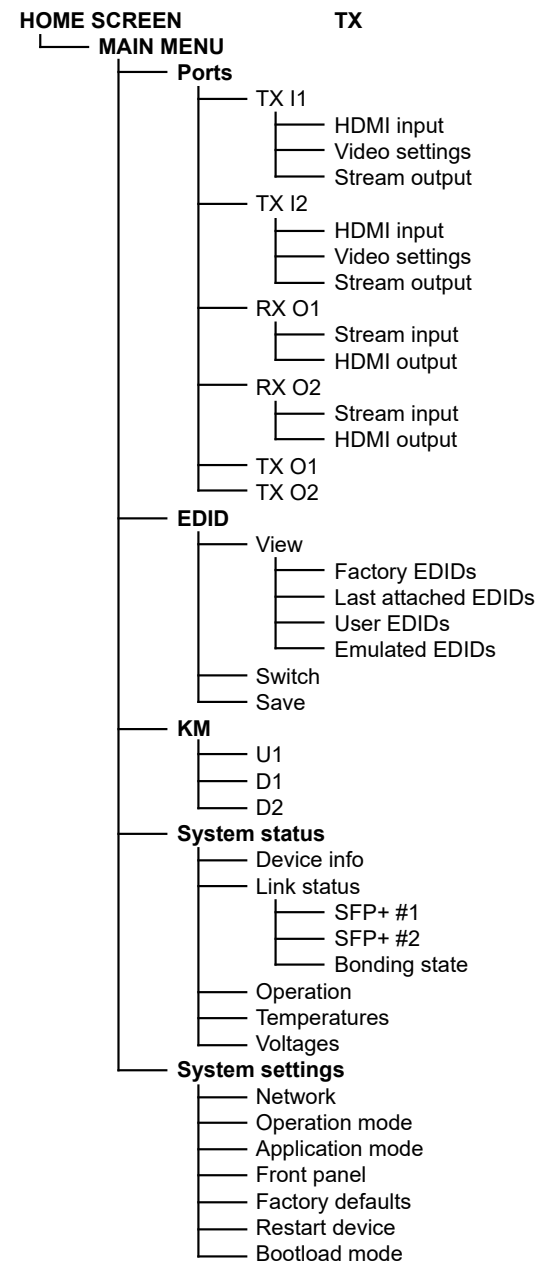

The tree structure of the receiver (RX) operation mode

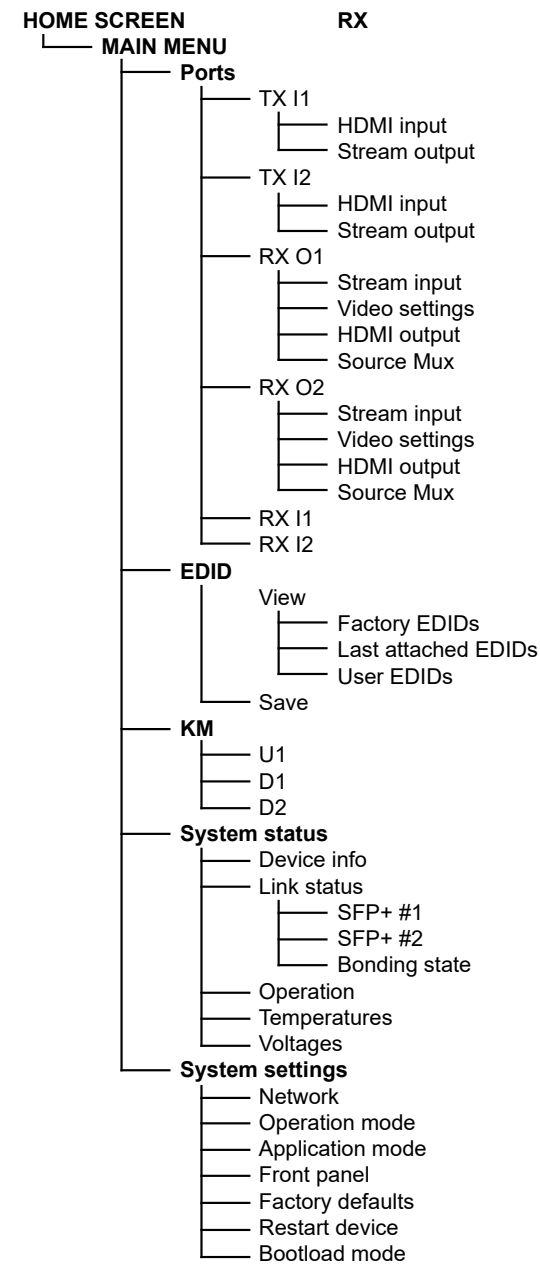

The tree structure of the transceiver (TRX) operation mode

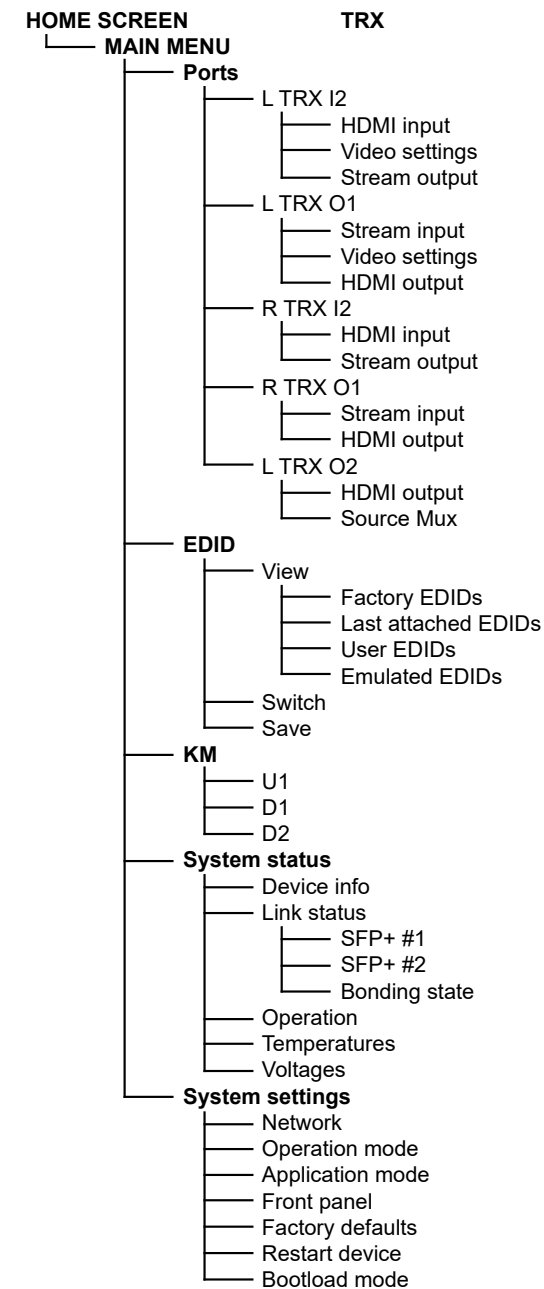

The tree structure of the multiviewer (RXMV) operation mode

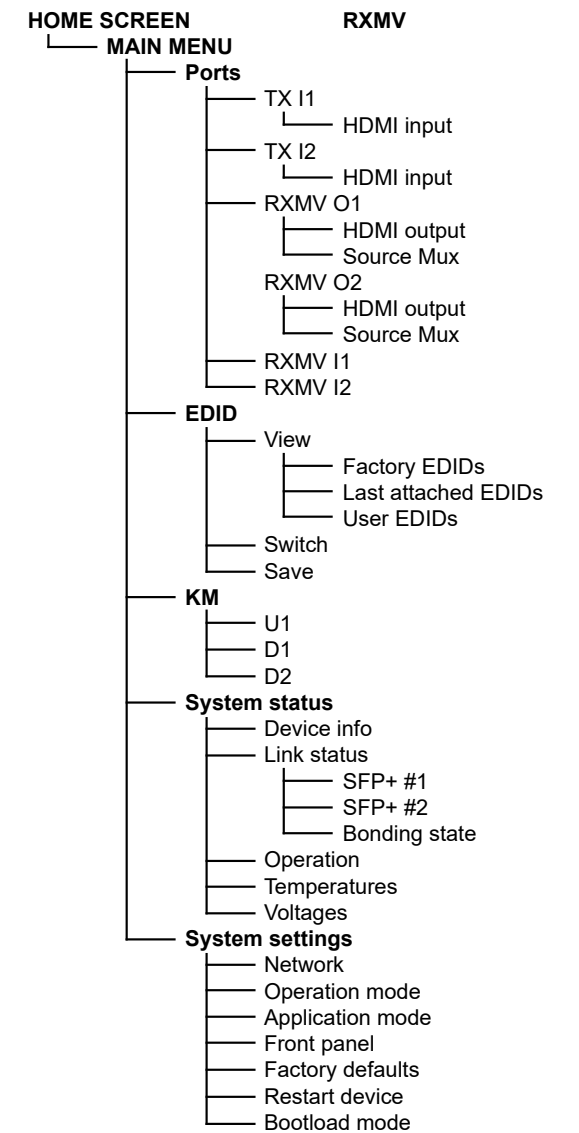

3.2. Introduction

3.2.1. Menu Navigation

The front panel has a color LCD that shows the most important settings and parameters structured in a menu. The jog dial control knob can be used to navigate between the menu items or change the value of a parameter. The knob can be turned and clicked to enter a menu or edit/set a parameter.

TIPS AND TRICKS: The faster you rotate the jog dial, the faster the parameter list is scrolled.

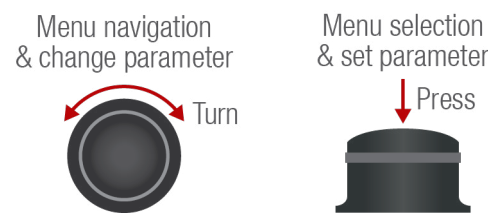

3.2.2. Operation Mode Visualization

The current operation mode of the UBEX endpoint is displayed with two methods on the LCD screen for the easier recognition:

- The color of the header is **blue** for the transmitter, **white** for the receiver, and **black with a white stripe** for the transceiver;
- There is a TX, RX or TRX label in the main menu of the menu structure.

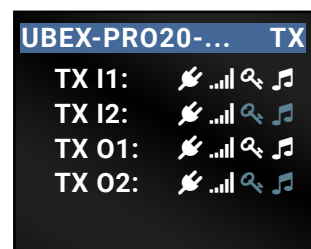

Home screen of the transmitter

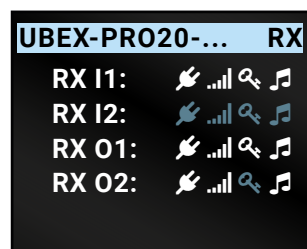

Home screen of the receiver

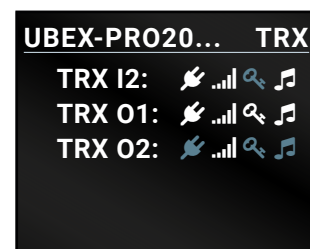

Home screen of the transceiver

3.2.3. Parameter Selection

The **blue** colored line means the selected menu/parameter, the **green** one means the current setting.

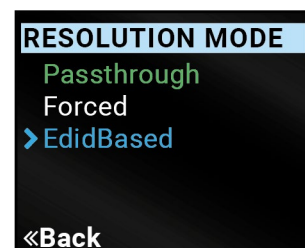

3.3. Home Screen

The current status of the input and output ports of the device is summarized on the Home screen. The device label (which can be modified by the user) and the operation mode is displayed in the top row.

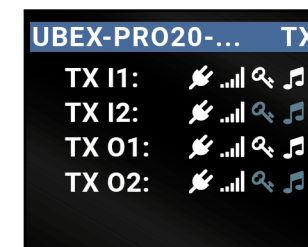

Home screen of the transmitter

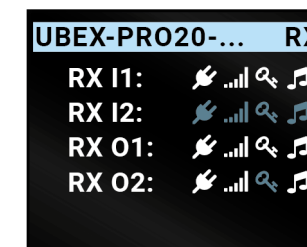

Home screen of the receiver

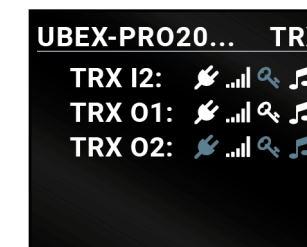

Home screen of the transceiver

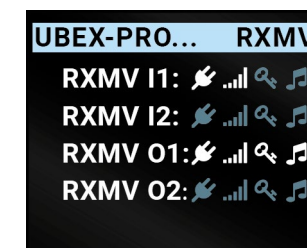

Home screen of the multiviewer

The **device label** can be modified via the following methods:

- Using the Lightware Device Controller (LDC) software - see the details in the [Status Tab](#) section.
- Using LW3 protocol command - see the details in the [Set the Device Label](#) section.

The icons display information about the port and the incoming/transmitted signals.

Icon	Icon is blue (inactive)	Icon is white (active)
	Sink is not connected	Sink is connected
	Signal is not present	Signal is present
	Signal is not encrypted with HDCP	Signal is encrypted with HDCP
	No audio signal in the video stream	Audio is embedded in the video stream

Take any action (turning or pressing) with the jog dial control knob to enter the **Main menu**.

3.4. Ports Menu - Transmitter Operation Mode

The most important settings and status information of the HDMI ports are available in the Ports menu.

The four local HDMI ports and the remote HDMI ports of the connected device are listed in the Ports menu of the transmitter.

INFO: The displayed remote ports depend on the operation mode of the connected remote device. It is different when the connected device is a receiver or a transceiver.

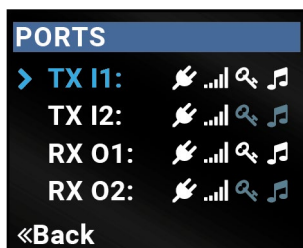

Local ports	Remote ports if the connected device is RECEIVER (RX)	Remote ports if the connected device is TRANSCIEVER (TRX)
TX I1	RX O1	TRX I2
TX I2	RX O2	TRX O1
TX O1		
TX O2		

Select the desired input or output port and enter to see the submenus.

3.4.1. TX I1 and TX I2 Ports

HDMI Input

The HDCP setting and information about the HDMI inputs are displayed:

- **HDCP enable** - Enabled / Disabled *#hdc*
- +5V present
- Signal present
- Active resolution
- Total resolution
- Color space

Video Settings

The following settings can be set in the case of both input ports:

- **Resolution mode** *#scaler #frc*
 - Passthrough: pass-through mode; the original resolution of the stream is transmitted.
 - Forced: the resolution that is set in the Resolution setting menu is forced.
- **Resolution setting** - select a resolution to force from the pre-installed list. The entire list can be found in the [Resolutions of the Scaler](#) section.
- **Image position** - Center / Fit / Stretch

DIFFERENCE: The transmitter is built with scaler function on both HDMI input ports **from firmware version v2.4.1**. The Image position setting on the HDMI in 2 port is a read-only parameter and fixed as *Center* in case of previous firmware versions.

- **Color space** - Passthrough / Force RGB / Force YCbCr 4:4:4 / Force YCbCr 4:2:2 *#csc #colorspace*
- **Color depth** - Passthrough / 8 bpc / 10 bpc / 12 bpc *#colordepth*

Stream Output

The following settings and information are related to the video stream sent toward the remote RX endpoint:

- **Stream enable** - Enabled / Disabled *#streamenable*
- Signal present
- Active resolution
- Total resolution
- Color space

3.4.2. RX O1 and RX O2 Ports

INFO: The following port status information is related to the remote output ports of the receiver.

Stream Input

The following information is displayed in the case of both streams transmitted to the receiver:

- Signal present
- Active resolution
- Total resolution
- Color space

HDMI Output

The following information is displayed in the case of both output ports of the receiver:

- Hotplug detect
- Signal present
- Active resolution
- Total resolution
- Color space

3.4.3. TX 01 and TX 02 Ports

The following information is displayed for both local output ports:

- **HDCP mode** - Auto / Always / Force 2.2 Type1
- **Output 5V mode** - Always on / Auto / Always off
- Hotplug detect
- Signal present
- Active resolution
- Total resolution
- Color space

#hdcpc #power5v

3.5. Ports Menu - Receiver Operation Mode

The most important settings and status information of the HDMI output ports and the local HDMI input ports are available in the Ports menu.

The four local HDMI ports and the remote HDMI ports of the connected device are listed in the Ports menu of the receiver.

INFO: The displayed remote ports depend on the operation mode of the connected remote device. It is different when the connected device is a transmitter or a transceiver.

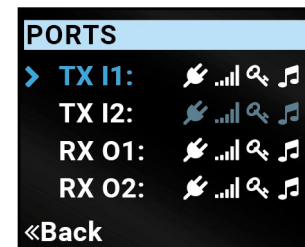

Local ports	Remote ports if the connected device is TRANSMITTER (TX)	Remote ports if the connected device is TRANSCEIVER (TRX)
RX 01	TX I1	TRX I2
RX 02	TX I2	TRX O1
RX I1		
RX I2		

Select the desired input or output port and enter to see the submenus.

3.5.1. TX I1 and TX I2 Ports

INFO: The following port status information is related to the remote input ports of the transmitter.

HDMI Input

The following information is displayed in the case of both input ports of the transmitter:

- +5V present
- Signal present
- Active resolution
- Total resolution
- Color space

Stream Output

The following information is displayed in the case of both input ports of the transmitter:

- Signal present
- Active resolution
- Total resolution
- Color space

3.5.2. RX 01 and RX 02 Ports

Stream Input

The following settings and information are related to the stream coming from the input ports of the connected device:

- **Stream enable** - Enabled / Disabled #streamenable
- **Stream source** - TX HDMI input 1 / TX HDMI input 2 #switch #crosspoint
- Signal present
- Active resolution
- Total resolution
- Color space

Video Settings

The following settings can be set in the case of both output ports:

- **Resolution mode** #scaler #frc
 - Passthrough: pass-through mode; the original resolution of the stream is transmitted.
 - Forced: the resolution that is set in the Resolution setting menu is forced.
 - EdidBased: the resolution that is read out from the EDID of the connected sink device is forced.
- **Resolution setting** - select a resolution to force from the pre-installed list. The entire list can be found in the [Resolutions of the Scaler](#) section.
- **Image position** - Center / Fit / Stretch

DIFFERENCE: The receiver is built with scaler function on both HDMI output ports from firmware version v2.1.0. The Image position setting on the HDMI out 2 port is a read-only parameter and fixed as *Center* in case of previous firmware versions.

- **Color space** - Passthrough / Force RGB / Force YCbCr 4:4:4 / Force YCbCr 4:2:2 #csc #colorspace
- **Color depth** - Passthrough / 8 bpc / 10 bpc / 12 bpc #colordepth

- **No Sync mode** - the No sync mode feature generates an image that can be displayed when there is no incoming signal on the port. The following settings can be set for the Test Pattern function: `#testpattern #nosyncscreen`
 - **Always off** - the test pattern function is disabled, the video output port transmits the video signal of the selected input port.
 - **No signal mode** - the video output port transmits the test pattern if there is no incoming signal on the selected input port.
 - **Always on** - the video output port always transmits the test pattern.
 - **Freeze** - the signal freezes at the last video frame on the sink device (the sink may show a broken frame as well). `#freeze`

HDMI Output

The following information is displayed in the case of both output ports of the receiver: `#hdcp #power5v`

- **HDCP mode** - Auto / Always / Force 2.2 Type1
- **Output 5V mode** - Always on / Auto / Always off
- Hotplug detect
- Signal present
- Active resolution
- Total resolution
- Color space

Source Mux

The source multiplexer (**Source MUX**) makes routing several different source signals to the HDMI output ports available. See more details about this function in the [Receiver Mode](#) section. `#mux #sourcemux`

- **Stream (D1) / Stream (D2)** - The signal source of the output port is the stream coming from the remote device.
- **Loopback (I1) / Loopback (I2)** - The signal source of the output port is the stream of the local input port of the receiver.
- **Copy (O1)** - The device is able to copy the signal of the HDMI out 1 port. This is the COPY function.

INFO: The Copy function is available only on the HDMI out 2 (RX O2) port.

3.5.3. RX I1 and RX I2 Ports

The following information is displayed for both local input ports: The HDCP setting and information about the HDMI inputs are displayed:

- **HDCP enable** - Enabled / Disabled `#hdcp`
- +5V present
- Signal present
- Active resolution
- Total resolution
- Color space

3.6. Ports Menu - Transceiver Operation Mode

The most important settings and status information of the HDMI input 1 and the HDMI output ports are available in the Ports menu.

The three local HDMI ports and the remote HDMI ports of the connected device are listed in the Ports menu of the transceiver.

INFO: The displayed remote ports depend on the operation mode of the connected remote device. It is different when the connected device is another transceiver, transmitter or a receiver.

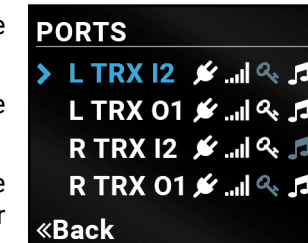

Local ports	Remote ports if the connected device is TRANSCEIVER (TRX)	Remote ports if the connected device is TRANSMITTER (TX)	Remote ports if the connected device is RECEIVER (RX)
L TRX I2	R TRX I2	TX I1	RX O1
L TRX O1	R TRX O1	TX I2	RX O2
L TRX O2			

Select the desired input or output port and enter to see the submenus.

3.6.1. L (Local) TRX I2 Port

HDMI Input

The HDCP setting and information about the HDMI input 1 port are displayed:

- **HDCP enable** - Enabled / Disabled `#hdcp`
- +5V present
- Signal present
- Active resolution
- Total resolution
- Color space

Video Settings

The following settings can be set for the stream of the HDMI input 2 port:

- **Resolution mode** *#scaler #frc*
 - Passthrough: pass-through mode; the original resolution of the stream is transmitted.
 - Forced: the resolution that is set in the Resolution setting menu is forced.
- **Resolution setting** - select a resolution to force from the pre-installed list. The entire list can be found in the [Resolutions of the Scaler](#) section.
- **Image position** - Center / Fit / Stretch

DIFFERENCE: The transceiver is built with scaler function on the HDMI input 2 port from firmware version v2.1.0. The Image position setting on this port is a read-only parameter and fixed as *Center* in case of previous firmware versions.

- **Color space** - Passthrough / Force RGB / Force YCbCr 4:4:4 / Force YCbCr 4:2:2 *#csc #colorspace*
- **Color depth** - Passthrough / 8 bpc / 10 bpc / 12 bpc *#colordepth*

Stream Output

The following settings and information are related to the video stream that is sent toward the remote TRX endpoint:

- **Stream enable** - Enabled / Disabled *#streamenable*
- Signal present
- Active resolution
- Total resolution
- Color space

3.6.2. L (Local) TRX O1 Port

Stream Input

The following settings and information are related to the video stream coming from the input port of the remote TRX endpoint:

- **Stream enable** - Enabled / Disabled *#streamenable*
- Signal present
- Active resolution
- Total resolution
- Color space

Video Settings

The following settings can be set for the stream of the HDMI output 1 port:

- **Resolution mode** *#scaler #frc*
 - Passthrough: pass-through mode; the original resolution of the stream is transmitted.
 - Forced: the resolution that is set in the Resolution setting menu is forced.
 - EdidBased: the resolution that is read out from the EDID of the connected sink device is forced.
- **Resolution setting** - select a resolution to force from the pre-installed list. The entire list can be found in the [Resolutions of the Scaler](#) section.
- **Image position** - Center / Fit / Stretch
- **Color space** - Passthrough / Force RGB / Force YCbCr 4:4:4 / Force YCbCr 4:2:2 *#csc #colorspace*
- **Color depth** - Passthrough / 8 bpc / 10 bpc / 12 bpc *#colordepth*
- **No sync mode** - the No sync mode feature generates an image that can be displayed when there is no incoming signal on the port. The following settings can be set for the Test Pattern function: *#testpattern #nosyncscreen*
 - **Always off** - the test pattern function is disabled, the video output port transmits the video signal of the selected input port.
 - **No signal mode** - the video output port transmits the test pattern if there is no incoming signal on the selected input port.
 - **Always on** - the video output port always transmits the test pattern.
 - **Freeze** - the signal freezes at the last video frame on the sink device (the sink may show a broken frame as well). *#freeze*

HDMI Output

The following information is displayed for the HDMI output 2 port of the transceiver: *#hdcp #power5v*

- **HDCP mode** - Auto / Always / Force 2.2 Type1
- **Output 5V mode** - Always on / Auto / Always off
- Hotplug detect
- Signal present
- Active resolution
- Total resolution
- Color space

3.6.3. R (Remote) TRX I2 Port

The following information is related to the HDMI input port of the connected remote transceiver.

HDMI Input

- +5V present
- Signal present
- Active resolution
- Total resolution
- Color space

Stream Output

- Signal present
- Active resolution
- Total resolution
- Color space

3.6.4. R (Remote) TRX O1 Port

The following information is related to the HDMI output port of the connected remote transceiver.

Stream Input

- Signal present
- Active resolution
- Total resolution
- Color space

HDMI Output

- Hotplug detect
- Signal present
- Active resolution
- Total resolution
- Color space

3.6.5. L (Local) TRX O2 Port

The following information is displayed for the local output port:

HDMI Output

- **HDCP mode** - Auto / Always *#hdcp*
- **Output 5V mode** - Always on / Auto / Always off
- Hotplug detect
- Signal present
- Active resolution
- Total resolution
- Color space

Source Mux

The source multiplexer (**Source MUX**) makes routing several different source signals to the HDMI out 2 port available. See more details about this function in the [Transceiver Mode](#) section. *#mux #sourcemux*

- **Loopback (I2)**- The signal source of the output port is the stream of the HDMI in 2 port of the transceiver.
- **Copy (O1)** - The device is able to copy the signal of the HDMI out 1 port. This is the COPY function.

3.7. Ports Menu - Multiviewer Operation Mode

DIFFERENCE: The multiviewer operation mode is only available from firmware package v3.2.0.

The most important settings and status information of the HDMI output ports and the local HDMI input ports are available in the Ports menu.

The four local HDMI ports and the remote HDMI ports of the connected device are listed in the Ports menu of the multiviewer.

INFO: The displayed remote ports depend on the operation mode of the connected remote device. It is different depending on whether the connected device is a transmitter or a transceiver.

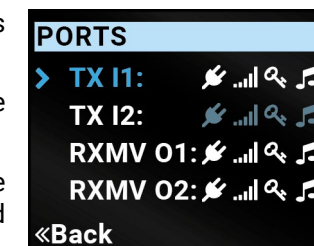

Local ports	Remote ports if the connected device is TRANSMITTER (TX)	Remote ports if the connected device is TRANSCEIVER (TRX)
RXMV O1	TX I1	TRX I2
RXMV O2	TX I2	TRX O1
RXMV I1		
RXMV I2		

Select the desired input or output port and enter to see the submenus.

3.7.1. TX I1 and TX I2 Ports

INFO: The following port status information is related to the remote input ports of the transmitter.

HDMI Input

The following information is displayed in case of both input ports of the transmitter:

- +5V present
- Signal present
- Active resolution
- Total resolution
- Color space

Stream Output

The following information is displayed in case of both input ports of the transmitter:

- Signal present
- Active resolution
- Total resolution
- Color space

3.7.2. RXMV 01 and RXMV 02 Ports

HDMI Output

The following information is displayed in case of both output ports of the receiver: *#hdcpc #power5v*

- **HDCP mode** - Auto / Always / Force 2.2 Type1
- **Output 5V mode** - Always on / Auto / Always off
- Hotplug detect
- Signal present
- Active resolution
- Total resolution
- Color space

Source Mux (RXMV 01)

The source multiplexer (**Source MUX**) makes routing several different source signals to the HDMI output ports available. See more details about this function in the [Multiviewer Mode](#) section. *#mux #sourcemux*

- **MV1** - The signal source of the output port is the multiview stream (canvas & tiles).
- **Loopback (I1)** - The signal source of the output port is the stream of the local input port of the multiviewer.

Source Mux (RXMV 02)

The source multiplexer (**Source MUX**) makes routing several different source signals to the HDMI output ports available. See more details about this function in the [Multiviewer Mode](#) section. *#mux #sourcemux*

- **Stream (D5)** - The signal source of the output port is the stream coming from the remote device.
- **Loopback (I2)** - The signal source of the output port is the stream of the local input port of the multiviewer.
- **Copy (O1)** - The device is able to copy the signal of the HDMI out 1 port. This is the COPY function.

INFO: The Copy function is available only on the HDMI out 2 (RXMV 02) port.

3.7.3. RX I1 and RX I2 Ports

The following information is displayed for both local input ports:

The HDCP setting and information about the HDMI inputs are displayed:

- **HDCP enable** - Enabled / Disabled *#hdcpc*
- +5V present
- Signal present
- Active resolution
- Total resolution
- Color space

3.8. EDID Menu

Advanced EDID Management is available in the front panel LCD menu, which allows for an EDID to be viewed, switched or be saved to the User EDID memory. See more information about EDID technology in the [EDID Management](#) section. The EDID memory structure of the device can be found in the [Advanced EDID Management](#) section. *#edid*

3.8.1. View

Select the desired EDID memory block: **Factory EDIDs**, **Last attached EDIDs**, **User EDIDs**, or **Emulated EDIDs** (only in case of transmitter and transceiver operation modes). Select the Name item and press the knob. Use the jog dial to step between the EDIDs. The following information can be checked:

- Preferred Resolution
- Monitor Name
- Audio Info

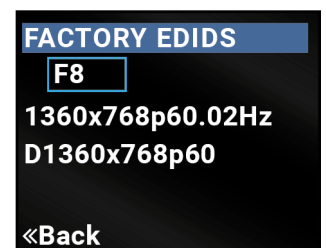
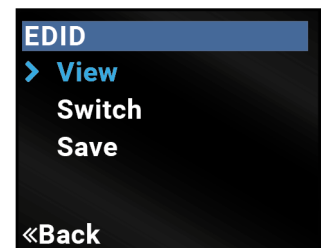

3.8.2. Switch

INFO: The Switch menu is available in the Transmitter mode only.

The submenu looks similar to the View submenu, but in this case the Destination is also listed. To change an EDID, do the following steps:

Step 1. Navigate to the **EDID / Switch** submenu.

Step 2. Select the **Source** EDID item and press the knob. Use the jog dial to select the desired EDID (F1-F144, U1-U12, or D1-D4) and press the knob.

Step 3. Select the **Destination** item and press the knob. Use the jog dial to select the desired EDID memory (E1-E2, All) and press the knob.

Step 4. Navigate to the **Switch** option and press the knob.



3.8.3. Save

The EDID of a connected sink can be saved to the User EDID memory as follows:

Step 1. Navigate to the **EDID / Save** submenu.

Step 2. Select the **Source** EDID item and press the knob. Use the jog dial to select the desired EDID (D1-D4) and press the knob.

Step 3. Select the **Destination** item and press the knob. Use the jog dial to select the desired EDID memory (U1-U12) and press the knob.

Step 4. Navigate to the **Save** option and press the knob.

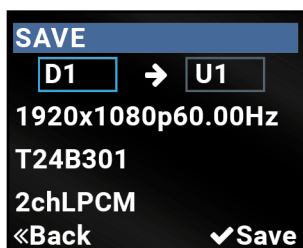

3.9. System Status Menu

The most important status information is displayed about the extender in the menu. *#status*

Device Info

Hardware- and software-related information is listed in the submenu, e.g. **device label** - this is a user defined unique name, which can be set in the LDC software (see the details in the [Status Tab](#) section) or with LW3 protocol command (see the details in the [Set the Device Label](#) section), and **serial number**, **firmware version**, etc. *#firmwareversion*

Link Status

The current status of the optical or DAC connection, advanced information about the installed SFP+ modules, and the bonding state are available under the menu.

Operation

The uptime and the operation time can be read out from the menu.

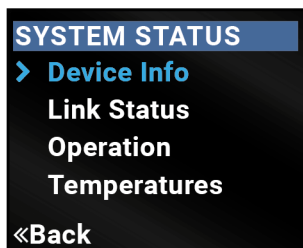

Temperatures

The recent temperature of the CPU, the system, and the FPGA are displayed in the menu.

ATTENTION: If the front panel Status LED blinks, check the temperatures under this menu and ensure the correct air flow for the device.

Voltages

The recent voltages of the device are displayed in the menu.

WARNING! If the front panel Status LED blinks, power off the device immediately.

3.10. KM Menu

DIFFERENCE: This menu is available in the UBEX-PRO20-HDMI-F120, UBEX-PRO20-HDMI-F121 and UBEX-PRO20-HDMI-F130 models only. *#km #usbkm*

The most important settings and status information of the USB K+M function are displayed in the menu. Three submenus are under the KM menu: **U1**, **D1** and **D2**. The following table describes the meaning of these ports:

USB Port	Physical port	Description
U1	USB-B	U as Upstream
D1	USB-A (right (M) side)	D1 as Downstream 1
D2	USB-A (left (K) side)	D2 as Downstream 2

3.10.1. U1

Available Information and Settings:

- Device State
- VBus Present
- Enabled** - Enabled / Disabled

3.10.2. D1 and D2

Available Information and Settings:

- Device Present
- Interface Classes
- Device Class
- Product Name
- Manufacturer
- Power** - Enabled / Disabled
- Suspend** - Enabled / Disabled
- Enumeration State
- Composite Capability

3.11. System Settings Menu

System related settings are available in the menu, e.g. network settings, operation mode (TX / RX / TRX / RXMV), reloading the factory default values, etc.

3.11.1. Network

The parameters of the network connection can be set in this submenu. The first three lines (IP, Subnet, and Gateway parameters) show the current settings. If the DHCP option is disabled, three more parameters are listed that can be set for a static IP address:

- Static IP,
- Static subnet,
- Static gateway.

ATTENTION: If you change the network settings, always press the **Save** option under the Network menu (not only in the submenu of the parameter) to apply the new settings. *#network #ipaddress #dhcp #mac*

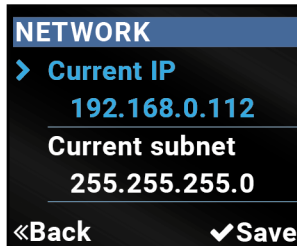

3.11.2. Operation Mode

The operation mode - the unit works as a transmitter, a receiver, or a transceiver - can be set in the submenu. *#operationmode #transmitter #receiver #transceiver #multiviewer #tx #rx #rxmv #trx*

Follow the steps to change the operation mode:

- Step 1.** Navigate to the **System settings / Operation mode** submenu.
- Step 2.** Select the **Switch mode...** option.
- Step 3.** Select the required mode: **Transmitter, Receiver, Transceiver** and **Multiviewer**.
- Step 4.** Confirm the selection, press the **Yes**.
- Step 5.** Wait until the device resets and reboots. After booting up, the unit works in the selected mode.

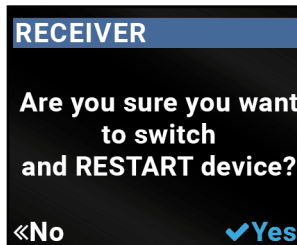
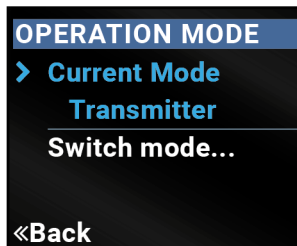

3.11.3. Application Mode

The current application mode (Extender or Matrix) is displayed in this submenu. For more details about the two modes, see the [Application Modes](#) section. *#applicationmode #extendermode #matrixmode*

3.11.4. Front Panel

Display Backlight

The brightness of the LCD can be set from 1 to 10 on a scale.

Dark Mode

The dark mode feature can be enabled or disabled. It keeps the LCD screen and the LEDs unlit to hide the device during an event when the mode is enabled. Pressing the rotatory knob in dark mode the display and LEDs will be enabled again for the configured dark mode timeout interval. *#darkmode*

Rotary Direction

The rotary direction of the jog dial control knob can be set in two ways: **CW Down** (clockwise down) or **CCW Down** (counter clockwise down). *#rotary #jogdial*

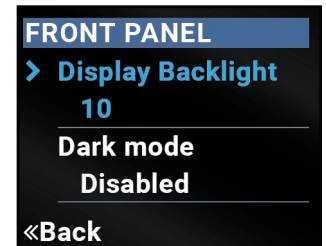

3.11.5. Factory Defaults

Selecting the submenu results in the factory default settings being reloaded to the device after a reboot. See the entire list of restored settings for the endpoint device in the [Factory Default Settings](#) section. *#factory*

3.11.6. Restart Device

This setting makes it possible to restart the device. It results in a reboot only and DOES NOT reload the factory default settings. *#restart #reboot*

3.11.7. Bootload Mode

Special function for entering the firmware update mode (bootload mode). See more details about the firmware update procedure in the [Firmware Update](#) chapter. *#bootload*

4

Installation

This chapter is about the installation of the device and connecting to other appliances, presenting also the mounting options and further assembly steps:

- ▶ Mounting Accessory Compatibility Table **37**
- ▶ Mounting Options - F-series Endpoint Devices **38**
- ▶ Mounting Options - R-series Endpoint Devices **39**
- ▶ Electrical Connections **42**
- ▶ Connections **45**
- ▶ SFP+ Slot Connection **54**
- ▶ Fiber Optical Cable Connections **54**
- ▶ Copper Cable Connections **55**
- ▶ Connection between F-series and R-series Endpoints **55**

4.1. Mounting Accessory Compatibility Table

The following table summarizes the compatibility of the UBEX F-series and R-series devices with the mounting accessories offered by Lightware. The number in the brackets means how many same-size devices can be assembled to the mounting plate. If there is no number, only one device can be mounted. The dimensions are in mm. The following accessories can be ordered separately, please contact sales@lightware.com for the details.

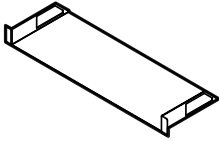
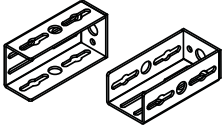
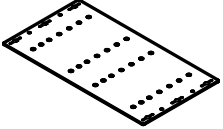
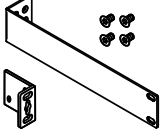
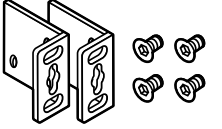
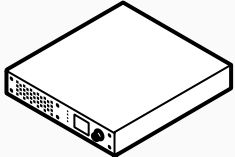
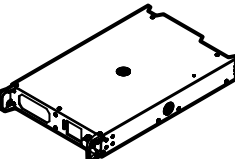
Dimensions (mm)	Model Name						
		1U High Rack Shelf	Mounting Bracket V2	UD Mounting Plate F120	Half Rack Mounting Kit	Rack Ear Mounting Kit	
		Details: Rack Shelf Mounting	Details: Mounting Bracket V2	Details: UD Mounting Plate F120	Details: Standard Rack Installation with One Unit	Details: Standard Rack Installation with Two Units	
221 W x 230 D x 42.5 H		UBEX-PRO20-HDMI-F100	✓ (2x)	✓	✓	✗	✗
		UBEX-PRO20-HDMI-F110	✓ (2x)	✓	✓	✗	✗
		UBEX-PRO20-HDMI-F111	✓ (2x)	✓	✓	✗	✗
		UBEX-PRO20-HDMI-F120	✓ (2x)	✓	✓	✗	✗
		UBEX-PRO20-HDMI-F121	✓ (2x)	✓	✓	✗	✗
		UBEX-PRO20-HDMI-F130	✓ (2x)	✓	✓	✗	✗
221 W x 364 D x 42.5 H		UBEX-PRO20-HDMI-R100 2xMM-2xDUO	✗	✗	✗	✓	✓ (2x)
		UBEX-PRO20-HDMI-R100 2xSM-2xDUO	✗	✗	✗	✓	✓ (2x)
		UBEX-PRO20-HDMI-R100 2xMM-QUAD	✗	✗	✗	✓	✓ (2x)
		UBEX-PRO20-HDMI-R100 2xSM-QUAD	✗	✗	✗	✓	✓ (2x)
		UBEX-PRO20-HDMI-R100 2xSM-BiDi-DUO	✗	✗	✗	✓	✓ (2x)

4.2. Mounting Options - F-series Endpoint Devices

Devices can be mounted in several ways, depending on the application. Besides using with rack shelf, a mounting bracket is available, which offers easy mounting on truss systems with standard clamps. The bracket can also be used for building the unit into the furniture:

WARNING! Always use the supplied screws. Using different (e.g. longer) ones may cause damage to the device.

ATTENTION: Pay attention to the ventilation holes when designing the system, especially when the extender is built into/under furniture. Front and rear ventilation holes must not be covered. If a UBEX device is installed in a closed space, the designer shall provide satisfactory ventilation to prevent excessive heat build-up inside.

INFO: The endpoint device is half-rack sized.

To order mounting accessories, please contact sales@lightware.com.

4.2.1. Mounting Bracket V2

Mounting bracket V2 gives an opportunity to mount the device to any furniture surface. Fasten the bracket on the side of the unit with the provided screws, and fasten it to a stand / board / truss / furniture.

Fixing the Bracket to the Device

Fasten the mounting bracket on the side of the unit with the provided screws (4 pcs M3 screws per Mounting bracket V2).



WARNING! M3x6 size is the longest allowed screw for fixing the ears to the housing. Using different (e.g. longer) ones may cause damage to the device.

Furniture Mounting

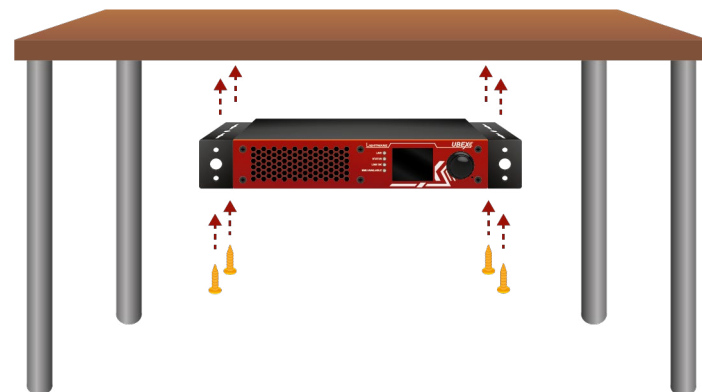

WARNING! Pay attention to the ventilation holes when designing the system. Front and rear ventilation holes must not be covered.

INFO: The chipboard screws are not supplied with the mounting kit.

4.2.2. UD Mounting Plate F120

UD mounting plate F120 gives an opportunity to mount the device to any furniture surface. Fasten the plate on the bottom of the unit with the provided screws, and fasten it to a stand / board / furniture.

Fixing the Plate to the Device

Fasten the mounting plate on the **bottom** of the unit with the provided screws (4 pcs M3 screws).

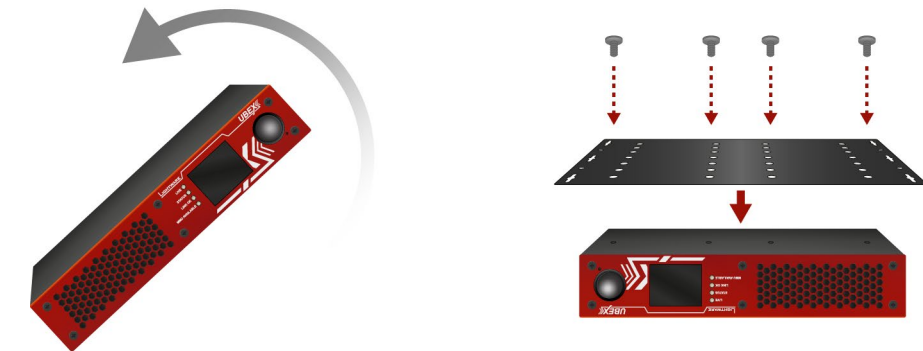

WARNING! M3x6 size is the longest allowed screw for fixing the ears to the housing. Using different (e.g. longer) ones may cause damage to the device.

Furniture Mounting

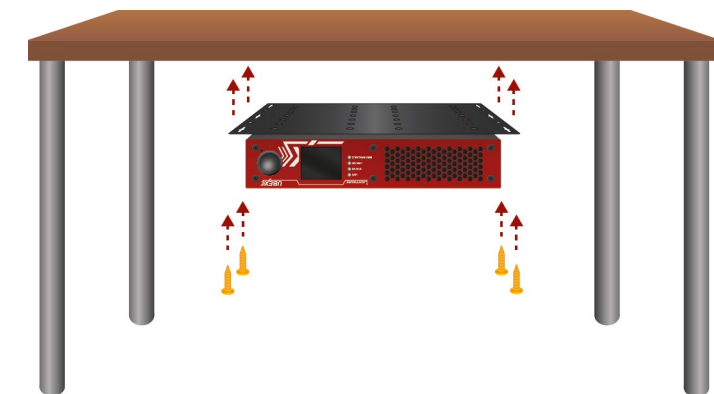

WARNING! Pay attention to the ventilation holes when designing the system. Front and rear ventilation holes must not be covered.

INFO: The chipboard screws are not supplied with the mounting kit.

4.2.3. Rack Shelf Mounting

Allows rack mounting for half-rack, quarter-rack and pocket sized units.

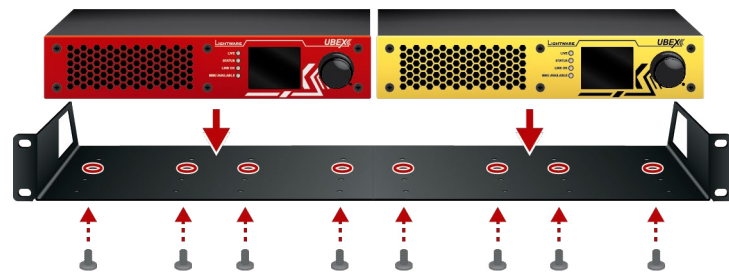

1U high rack shelf provides mounting holes for fastening two half-rack or four quarter-rack sized units. Pocket sized devices can also be fastened on the self.



WARNING! Pay attention to the ventilation holes when designing the system. Front and rear ventilation holes must not be covered.

INFO: The screws for the rack frame are not supplied with the device.

4.3. Mounting Options - R-series Endpoint Devices

UBEX R-series endpoint devices can be mounted in several ways, depending on the application. They can be mounted into the rack in pairs, or can be used standalone. Rack ears also serve easy handling and bump protection, and there are mounting threads on top and one side to conform strict installation safety regulations.

ATTENTION: To ensure the correct ventilation and avoid overheating, leave enough free space in front of and behind of the appliance and keep the ventilation holes free.

4.3.1. Truss Mounting

There are mounting threads on top and on one side for safe and secure installation. Rigging the handles with a safety wire rope is highly recommended for safety reasons.

To order mounting accessories, please contact sales@lightware.com. (Truss clamp and safety wire rope are not available for sales.)

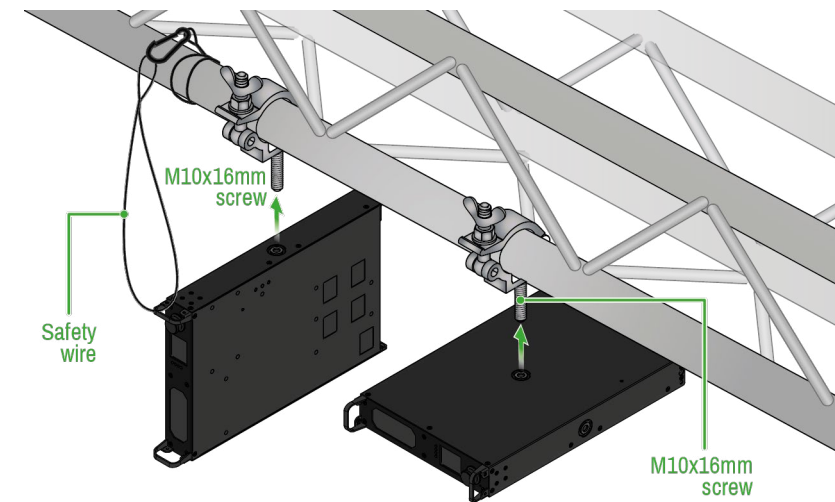

Truss mounting for R-series endpoint devices

4.3.2. Standard Rack Installation with Two Units

Rack mounting kit includes all necessary accessories for standard rack installation:

- 2 pcs rack ears (PN: 52400959 (2x)),
- 12 pcs black, M4x8mm hexagon socket countersunk head screws.

Rack mounting kit is not supplied with the product, it can be purchased separately, please contact sales@lightware.com.

Step 1. Take two devices directly next to each other.

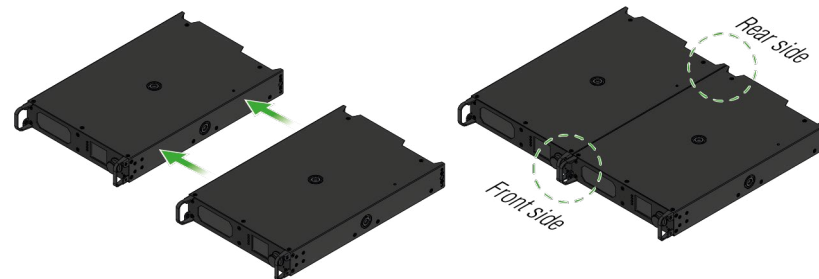

Step 2. Two mounting holes on the front ears and two on the back of the chassis is for fastening the two units to each other with 2x 2 pcs **M4x8 mm** screws. This way you get a one-rack wide and 1U high device.

Front View

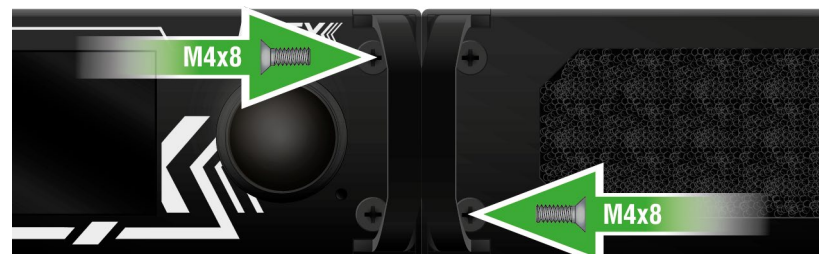

Rear View



ATTENTION: Take care of the mounting direction of the screws!

Front side

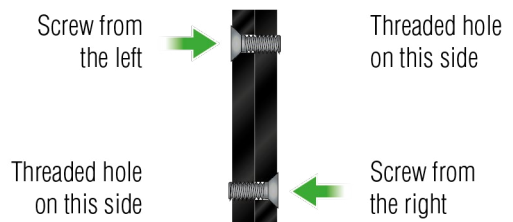

Rear side

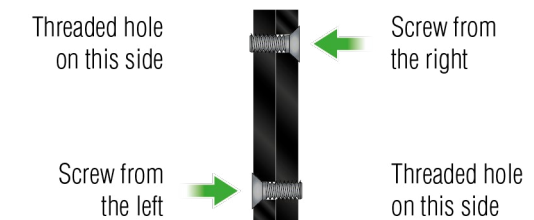

Mounting direction of the screws

Step 3. Take the rack ears on the left and right side of the extender pair as shown in the picture. Insert the screws into the holes and fix the front ears to the devices.

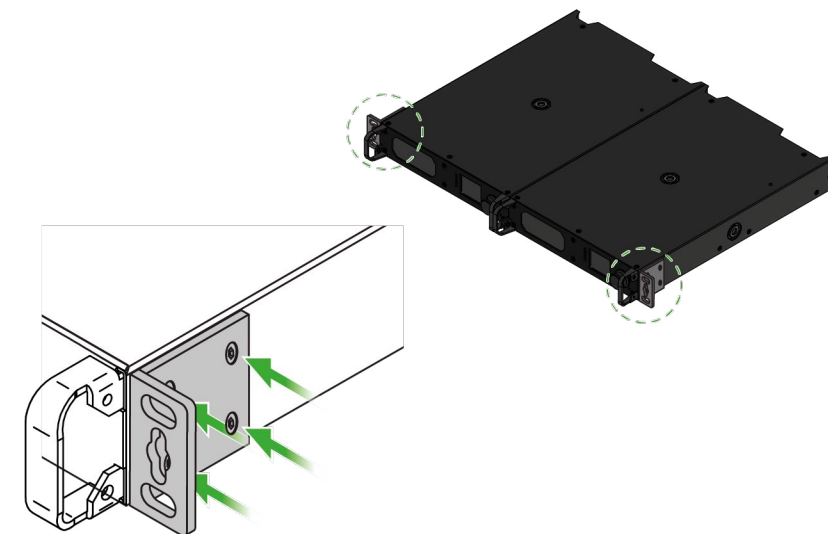

Assembly of the mounting ears

Step 4. As a final step, mount the unit in the rack.

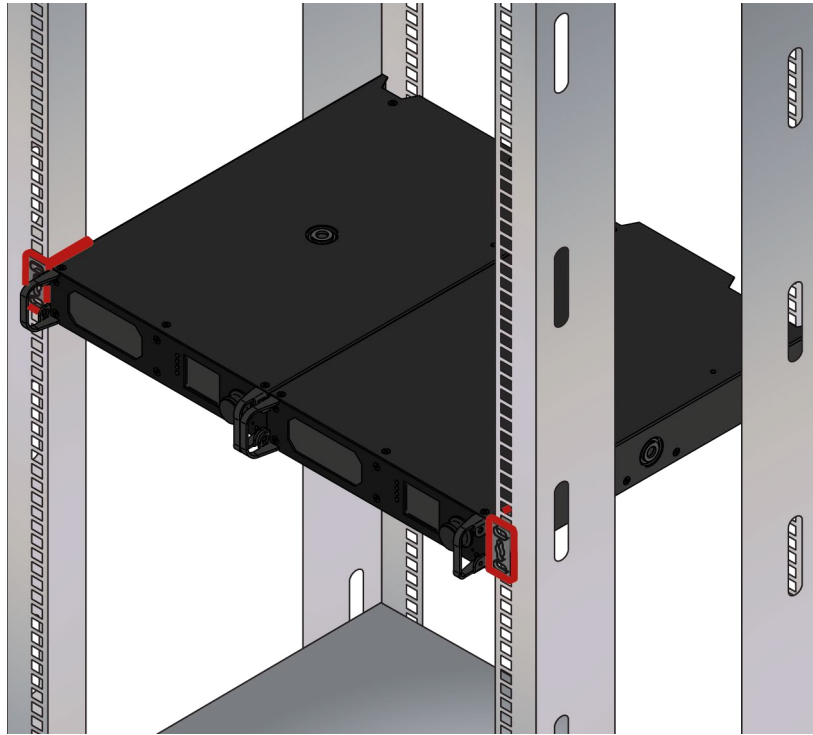

Standard rack installation

ATTENTION: Always use all four screws for fixing the rack ears to the rack rail. Choose properly sized screws for mounting. Keep a minimum of two threads left after the nut screw.

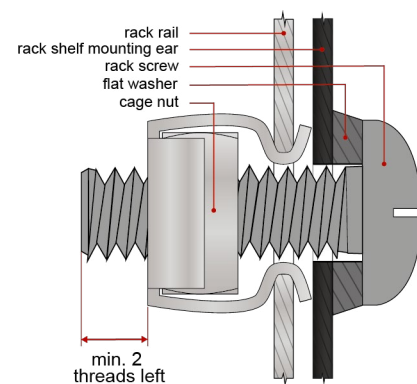

Mounting the rack ears to the rack rail

4.3.3. Standard Rack Installation with One Unit

Lightware provides a rack installation possibility for only one R100 unit with a standard and an extended rack ears. The rack mounting kit includes all necessary accessories for standard rack installation:

- 2 pcs rack ears (PN: 52400959 (1x) and 55450168 (1x)),
- 8 pcs black, M4x8mm hexagon socket countersunk head screws.

Rack mounting kit is not supplied with the product, it can be purchased separately, please contact sales@lightware.com.

Step 1. Take the rack ears on the left and right side of the extender pair as shown in the picture. Insert the screws into the holes and fix the front ears to the devices.

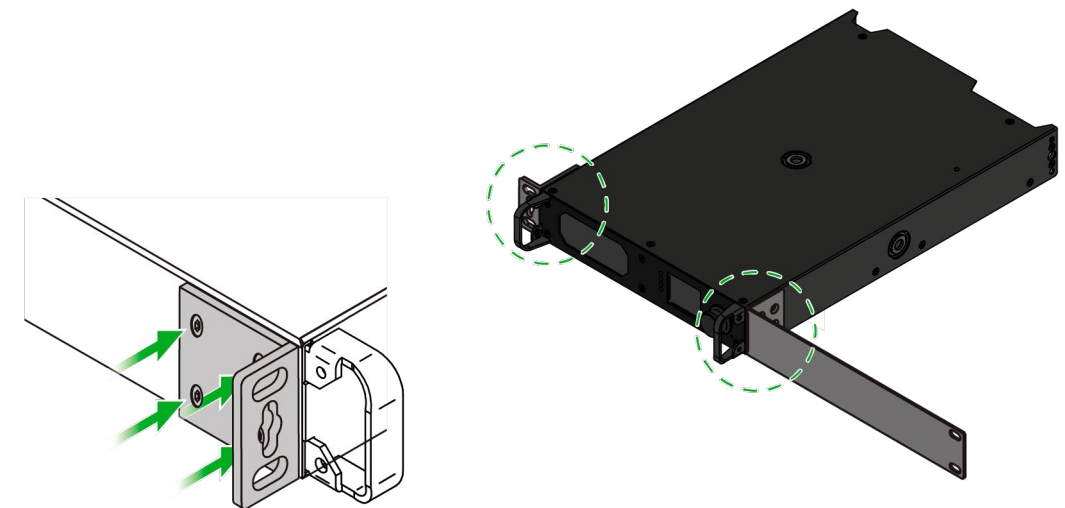

Assembly of the mounting ears

Step 2. As a final step, mount the unit in the rack.

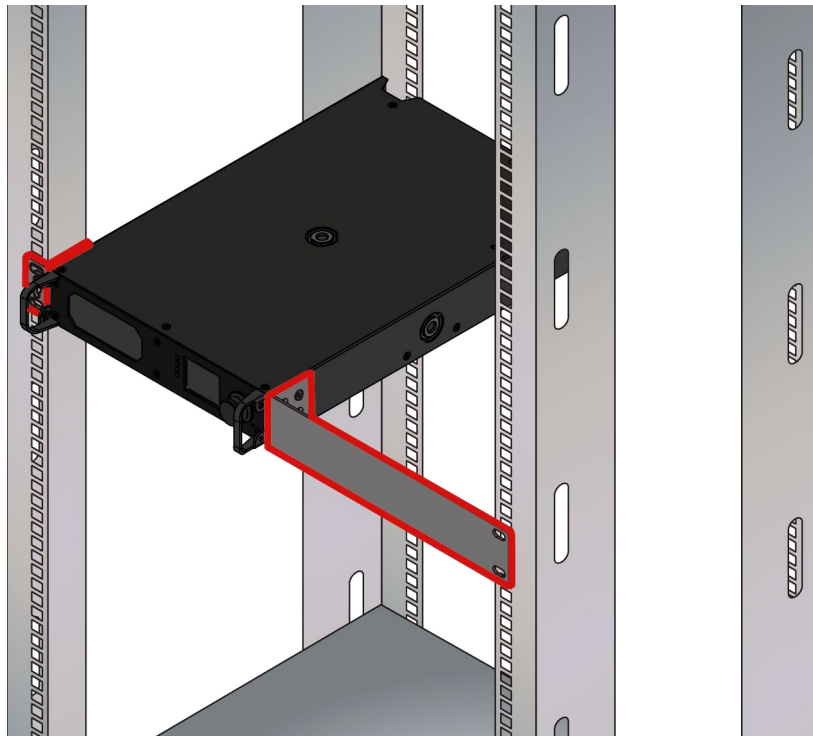

Standard rack installation

ATTENTION: Always use all four screws for fixing the rack ears to the rack rail. Choose properly sized screws for mounting. Keep a minimum of two threads left after the nut screw.

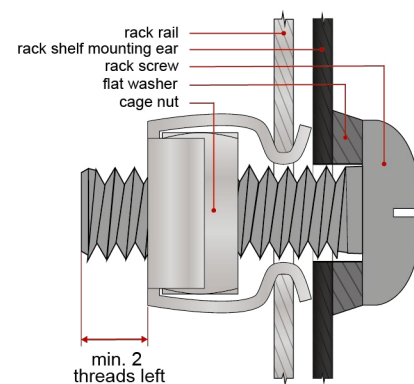

Mounting the rack ears to the rack rail

4.4. Electrical Connections

The following sections describe all possible electrical connections of the UBEX endpoint devices.

4.4.1. SFP / SFP+ Slots

DEFINITION: The small form-factor pluggable (SFP) is a compact, hot-pluggable optical module transceiver used for both telecommunication and data communication applications. It is a popular industry format jointly developed and supported by many network component vendors. *

DEFINITION: The enhanced small form-factor pluggable (SFP+) is an enhanced version of the SFP that supports data rates up to 10 Gbit/s. *

* Source: https://en.wikipedia.org/wiki/Small_form-factor_pluggable_transceiver

UBEX F-series endpoint devices contain 2 pieces standard SFP+ slots for the fiber optical connections via SFP+ modules or DAC cables. The installed SFP+ modules can be singlemode or multimode as well.



	Endpoint devices
Number of slots	2
Type of the slot	SFP+
Maximum bandwidth per slot	10 Gbps
Transmitted signal	Audio, video, Ethernet, RS-232, Infrared, USB K+M, USB KVM, USB 2.0

For the details about the DAC cable / SFP+ module installation, see the [SFP+ Slot Connection](#) section.

Maximum Allowed Cable Length

The maximum allowed optical or copper cable length depends of the installed SFP+ modules. Always check the specification of the optical modules before the fiber optical or copper cabling.

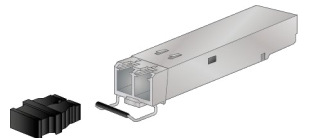

ATTENTION: Always apply equal length copper cables for both SFP+ to RJ45 modules in one endpoint device. Different cable lengths may cause data package lost during the transmission.

4.4.2. HDMI Connector

The endpoint device provides standard 19-pole HDMI connector for inputs and outputs with HDMI 2.0 support. Always use high quality HDMI cable for connecting sources and displays.



See more details about the AV interfaces in the [Video Interface](#) and the [Audio Interface](#) sections.

4.4.3. AC Power Connection

Standard IEC Connector

UBEX F-series endpoint devices contain standard IEC power connector and work with 100 to 240 Volts AC, 50 Hz or 60 Hz power sources.

Connect the power cord to the AC input connector; the extender is immediately powered on.



Neutrik powerCON TRUE1 Connector

UBEX R-series endpoint devices contain Neutrik powerCON TRUE1 NAC3MPX-WOT power connector and work with 100 to 240 Volts AC, 50 Hz or 60 Hz power sources.

Connect the Neutrik powerCON to the AC input connector; the extender is immediately powered on.

See the details about the assembly instructions for the Neutrik powerCON TRUE1 cables on the website of the vendor: <https://www.neutrik.com/en/product/nac3mx-w-top>



4.4.4. Symmetrical Analog Stereo Audio Connector

5-pole Phoenix connector is used for balanced analog audio (line in/out). Unbalanced audio signals can be connected as well. For asymmetrical output, connect only + and ground. For asymmetrical input connect + and ground to the source and connect – to the ground.



Pin nr.	Signal
1	Left+
2	Left-
3	Ground
4	Right-
5	Right+

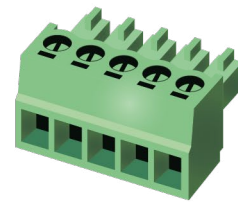

5-pole Phoenix connector pin assignments

Compatible Plug Type

Phoenix® Combicon series (3.5mm pitch), type: MC 1.5/5-ST-3.5.

See more information about the most common audio cable wiring modes in the [Audio Ports](#) section.

You can find more information about audio embedding and de-embedding functions in the [Audio Interface](#) section.

4.4.5. RS-232 Connector

UBEX-PRO20-HDMI-F110 and F120 models contain a 3-pole Phoenix connector, which is used for RS-232 serial connection.



Pin nr.	Signal
1	Ground
2	TX data
3	RX data

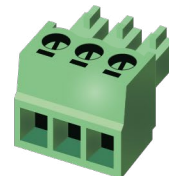

RS-232 connector pin assignments

Compatible Plug Type

Phoenix® Combicon series (3.5mm pitch, 3-pole), type: MC 1.5/3-ST-3.5.

You can find help for the correct wiring in the [Serial Ports](#) section.

You can find more information about serial interface in the [Serial Interface](#) section.

4.4.6. Ethernet Connectors

Standard RJ45 Connector

UBEX F-series endpoint devices provide standard RJ45 connectors for LAN and user Ethernet access. Always use high quality Ethernet cable.

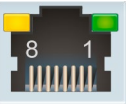

Neutrik etherCON Connector

UBEX R-series endpoint devices provide Neutrik etherCON NE8FDV-YK connector for LAN and user Ethernet access.

ATTENTION: The connector does not work with CAT6 cable connector (NE8MC6-MO) and NKE6S* cables.



Wiring of LAN Cables

Lightware recommends the termination of LAN cables on the basis of TIA/EIA T 568 A or TIA/EIA T 568 B standards.

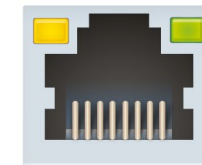

Pin	TIA/EIA T568A	TIA/EIA T568B
1	white/green	white/orange
2	green	orange
3	white/orange	white/green
4	blue	blue
5	white/blue	white/blue
6	orange	green
7	white/brown	white/brown
8	brown	brown

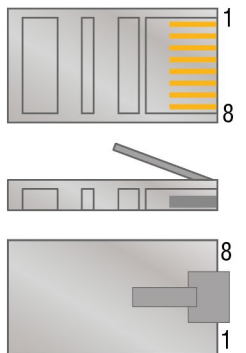



Wiring of LAN cables by types

WARNING! Never connect non-assembled CATx cable to the port while the unit is powered, it may damage the device.

4.4.7. Neutrik opticalCON Connectors

UBEX R-series endpoint devices are built with singlemode or multimode Neutrik opticalCON connectors.

	UBEX-PRO20-HDMI-R100 models				
	2xMM-2xDUO	2xSM-2xDUO	2xSM-BiDi-DUO	2xMM-QUAD	2xSM-QUAD
Number of connectors	2	2	1	1	1
Connector drawing					
Connector type	NO2-4FDW-A			NO4FDW-A	
Type of the SFP+ module inside the enclosure	2x Finisar FTLX8574D3BCL	2x Finisar FTLX1475D3BCL	Module A: 1x Finisar FTLX2072D327 Module B: 1x Finisar FTLX2072D333	2x Finisar FTLX8574D3BCL	2x Finisar FTLX1475D3BCL
Mode	Multimode	Singlemode	Singlemode	Multimode	Singlemode
Supported cable	LC, Neutrik opticalCON DUO	LC, Neutrik opticalCON DUO	LC, Neutrik opticalCON DUO	Neutrik opticalCON QUAD	Neutrik opticalCON QUAD
Number of required optical cables for 20GbE	2x Neutrik opticalCON DUO / 4x LC simplex / 2x LC duplex		1x Neutrik opticalCON DUO / 2x LC simplex	1x Neutrik opticalCON QUAD	

ATTENTION: The 2xSM-BiDi-DUO model **does not support** the Neutrik opticalCON DUO **crossed fiber wiring (A-A; B-B)** cables. Please use standard (A-B) cable only.

See the details about the maximum fiber cable extensions in the [R-series Endpoint](#) section.

See more details about the cabling between the Neutrik optical connectors and the SFP+ modules installed in a F-series endpoint in the [Connection between F-series and R-series Endpoints](#) section.

4.4.8. IR Connector

IR detector and IR emitter can be connected to the endpoint device with TRS (Tip, Ring, and Sleeve) connectors. They are also known as (3,5 mm or approx. 1/8") audio jack, phone jack, phone plug, and mini-jack plug. The pin assignments are the following for the detector and the emitter:

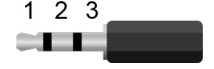
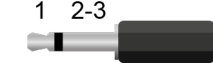
 Detector – 3-pole TRS		 Emitter – 2-pole TS	
1 Tip	Signal (active low)	1 Tip	+5V
2 Ring	GND	2 Ring	Signal (active low)
3 Sleeve	+5V	3 Sleeve	

INFO: Ring pole of the emitter is optional. If your IR emitter has three-pole TRS plug, then the Ring and the Sleeve are the same signal (Output -).

You can find more information about IR interface in the [Infrared Interface](#) section.

4.4.9. USB Mini-B Connector

UBEX series endpoint devices provide standard USB 2.0 mini B-type connector for software control and firmware update purpose.

4.4.10. USB-A Connectors

UBEX-PRO20-HDMI-F120, -F121 and -F130 endpoint models provide USB-A connectors for supporting K+M (F120 model) and KVM (F130 model) functionality. The device has 2 pieces of USB 2.0 A-type connectors.

ATTENTION: The USB K+M function supports **emulated (composite) mode only**. It means in the practice the perfect usage of special keyboard/mouse buttons (e.g. multimedia keyboards and touchpads) are not guaranteed because of the limitation of the emulated mode technology. Lightware recommends usage of ordinary keyboards built up to 104/105 keys and ordinary mice.

4.4.11. USB-B Connector

UBEX-PRO20-HDMI-F120 endpoint model provides a USB-B connector for supporting K+M functionality. The device has 1x USB 2.0 B-type connector.

4.4.12. USB-C Connector

UBEX-PRO20-HDMI-F121 and -F130 endpoint models provide a USB Type-C connector for USB connection between the extender and the host computer.

ATTENTION: The port receives **USB data only**, no AV signal transmission is accepted. It supports **USB 2.0 standard only**.

4.5. Connections

4.5.1. F-series Endpoints - Transmitter Operation Mode

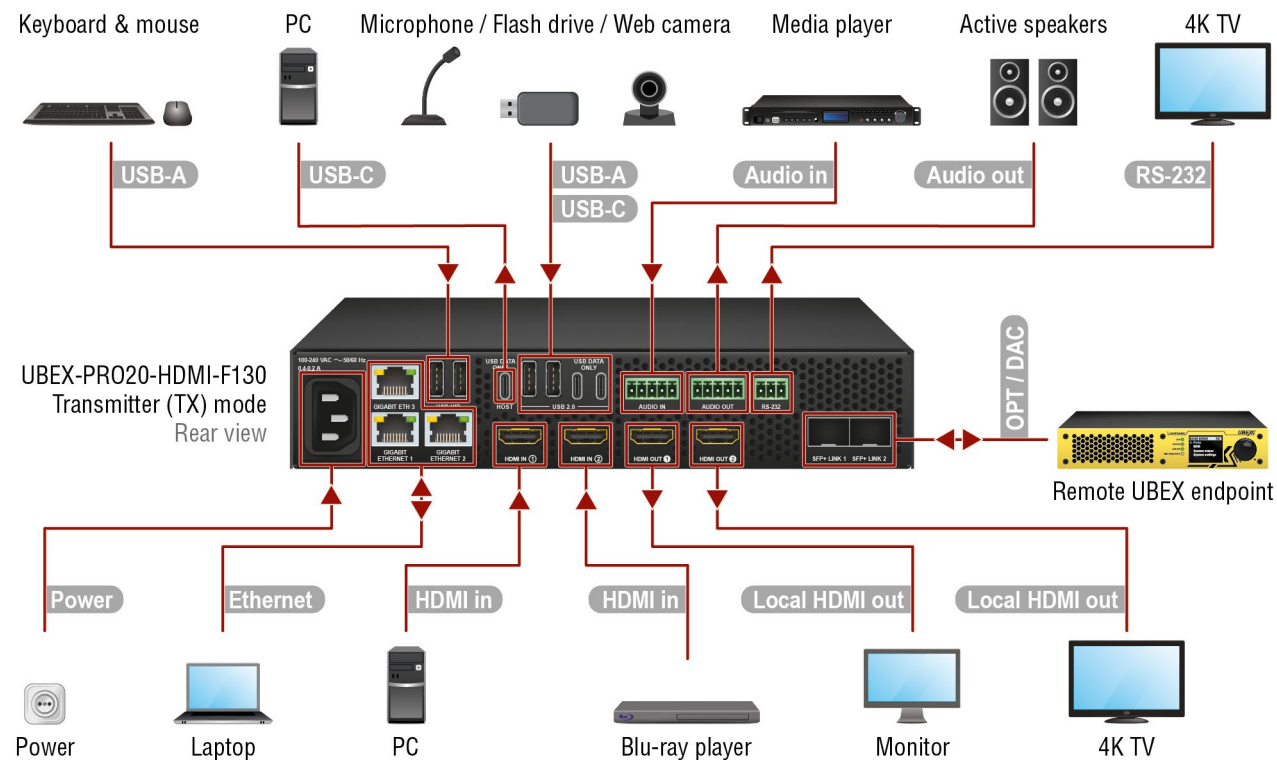

Connections for the F130 model in transmitter operation mode

Changing the Operation Mode

The operation mode of the UBEX endpoint device can be changed using the following methods:

- via **front panel LCD menu** - see the details in the [Operation Mode](#) section;
- via **Lightware Device Controller (LDC) software** - see the details in the [Status Tab](#) section;
- via **LW3 protocol command** - see the details in the [Set the Operation Mode](#) section.

For all F-series models	OPT DAC	Connect singlemode or multimode (depends on the installed SFP+ modules) fiber optical cables or DAC cables between the two UBEX endpoint devices. The Extender Mode is detected and applied automatically in the device once the connection is established successfully.
	HDMI in	Connect the source devices (e.g. PC, Blu-ray player) using the HDMI input 1 and 2 ports by HDMI cables.
	Local HDMI out	Connect the local sink devices (e.g. monitor, 4K TV) to the HDMI output 1 and 2 ports by HDMI cables. The ports transmit the original streams of the HDMI input ports.
	Ethernet	Optionally connect the transmitter to a LAN in order to control the device.
	Power	Connect the power adaptor to the AC input on the transmitter first, then to the AC power socket.
For F111, F121 and F130 models only	Audio in	Connect an audio source device (e.g. media player) to the audio input connector.
	Audio out	Connect an audio sink device (e.g. active speakers) to the audio output connector.
	RS-232	Optionally for RS-232 extension: connect the controlled unit (e.g. 4K TV) to the RS-232 port of the device with a serial cable.
For F121 and F130 models only	USB-C	Optionally for USB HID extension: connect the transmitter to the computer by a USB-C cable.
	USB-A	Optionally for USB HID extension: connect the USB HID devices to the transmitter (preferably mouse and keyboard).
For F130 model only	USB-A USB-C	USB 2.0 ports: connect the USB devices (e.g. microphone, flash drive, web camera, etc) to the extender for the USB 2.0 extension.

WARNING! User Ethernet is also transmitted over the SFP+ interface, so be sure not to create a network loop.

INFO: The HDMI output ports can be used as local output ports only when the device is configured as transmitter.

4.5.2. F-series Endpoints - Receiver Operation Mode

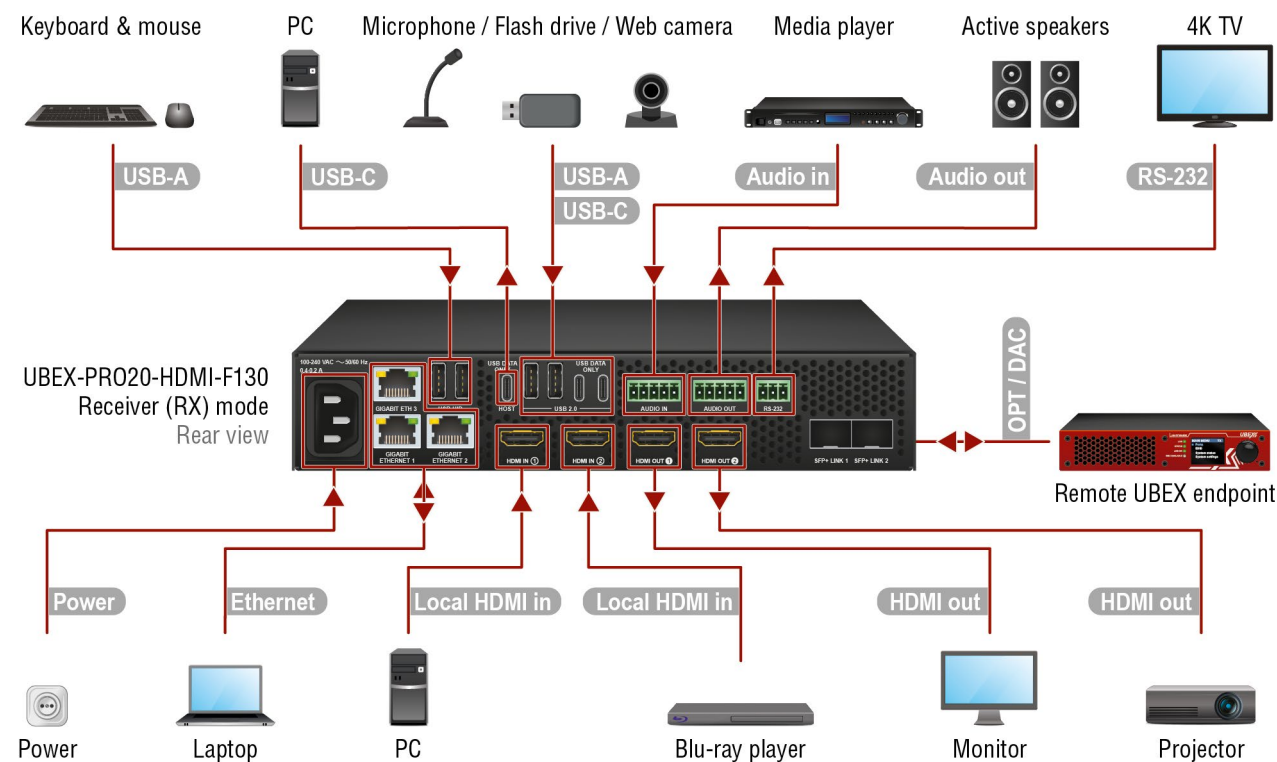

Connections for the F130 model in receiver operation mode

Changing the Operation Mode

The operation mode of the UBEX endpoint device can be changed using the following methods:

- via front panel LCD menu - see the details in the [Operation Mode](#) section;
- via **Lightware Device Controller (LDC) software** - see the details in the [Status Tab](#) section;
- via **LW3 protocol command** - see the details in the [Set the Operation Mode](#) section.

For all F-series models	OPT DAC	Connect singlemode or multimode (depends on the installed SFP+ modules) fiber optical cables or DAC cables between the two UBEX endpoint devices. The Extender Mode is detected and applied automatically in the device once the connection is established successfully.
	Local HDMI in	Connect the local source devices (e.g. PC, Blu-ray player) using the HDMI input 1 and 2 ports by HDMI cables.
	HDMI out	Connect the sink devices (e.g. monitor, projector) to the HDMI output 1 and 2 ports by HDMI cables.
	Ethernet	Optionally connect the receiver to a LAN in order to control the device.
	Power	Connect the power adaptor to the AC input on the receiver first, then to the AC power socket.
For F111, F121 and F130 models only	Audio in	Connect an audio source device (e.g. media player) to the audio input connector.
	Audio out	Connect an audio sink device (e.g. active speakers) to the audio output connector.
	RS-232	Optionally for RS-232 extension: connect the controlled unit (e.g. 4K TV) to the RS-232 port of the device with a serial cable.
For F121 and F130 models only	USB-C	Optionally for USB HID extension: connect the transmitter to the computer by a USB-C cable.
	USB-A	Optionally for USB HID extension: connect the USB HID devices to the transmitter (preferably mouse and keyboard).
For F130 model only	USB-A USB-C	USB 2.0 ports: connect the USB devices (e.g. microphone, flash drive, web camera, etc) to the extender for the USB 2.0 extension.

WARNING! User Ethernet is also transmitted over the SFP+ interface, so be sure not to create a network loop.

INFO: The HDMI input ports can be used as local input ports only when the device is configured as receiver.

4.5.3. F-series Endpoints - Transceiver Operation Mode

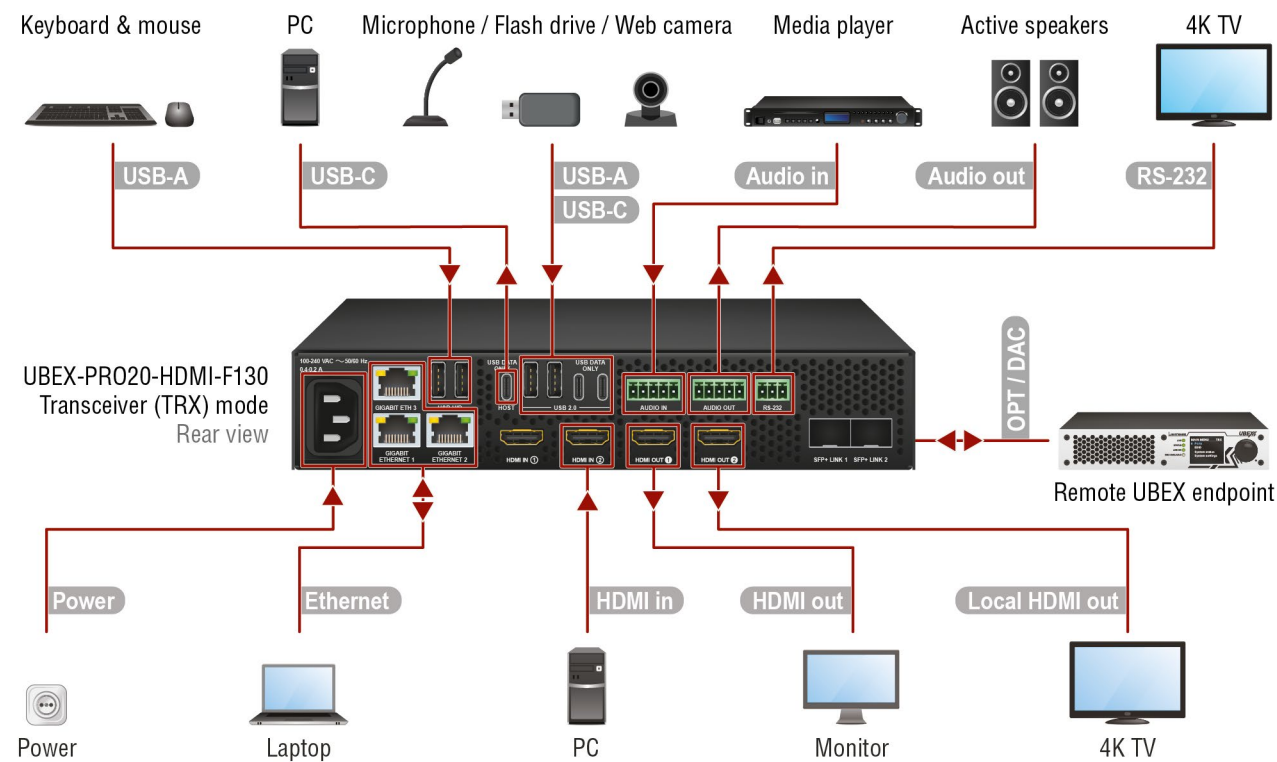

Connections for the F130 model in transceiver operation mode

Changing the Operation Mode

The operation mode of the UBEX endpoint device can be changed using the following methods:

- via front panel LCD menu - see the details in the [Operation Mode](#) section;
- via **Lightware Device Controller (LDC) software** - see the details in the [Status Tab](#) section;
- via **LW3 protocol command** - see the details in the [Set the Operation Mode](#) section.

For all F-series models	OPT DAC	Connect singlemode or multimode (depends on the installed SFP+ modules) fiber optical cables or DAC cables between the two UBEX endpoint devices. The Extender Mode is detected and applied automatically in the device once the connection is established successfully.
	HDMI in	Connect the transceiver and the source device (e.g. PC) using the HDMI input 2 port by an HDMI cable.
	HDMI out	Connect a sink device (e.g. monitor) to the HDMI output 1 port by an HDMI cable.
	Local HDMI out	Connect a local sink device (e.g. 4K TV) to the HDMI output 2 port by an HDMI cable. The port transmit the original stream of the HDMI in 2 port.
	Ethernet	Optionally connect the transceiver to a LAN in order to control the device.
	Power	Connect the power adaptor to the AC input on the transceiver first, then to the AC power socket.
For F111, F121 and F130 models only	Audio in	Connect an audio source device (e.g. media player) to the audio input connector.
	Audio out	Connect an audio sink device (e.g. active speakers) to the audio output connector.
	RS-232	Optionally for RS-232 extension: connect the controlled unit (e.g. 4K TV) to the RS-232 port of the device with a serial cable.
For F121 and F130 models only	USB-C	Optionally for USB HID extension: connect the transmitter to the computer by a USB-C cable.
	USB-A	Optionally for USB HID extension: connect the USB HID devices to the transmitter (preferably mouse and keyboard).
For F130 model only	USB-A USB-C	USB 2.0 ports: connect the USB devices (e.g. microphone, flash drive, web camera, etc) to the extender for the USB 2.0 extension.

WARNING! User Ethernet is also transmitted over the SFP+ interface, so be sure not to create a network loop.

INFO: The HDMI input 1 port cannot accept AV signal when the device is configured as transceiver.

4.5.4. F-series Endpoints - Multiviewer Operation Mode

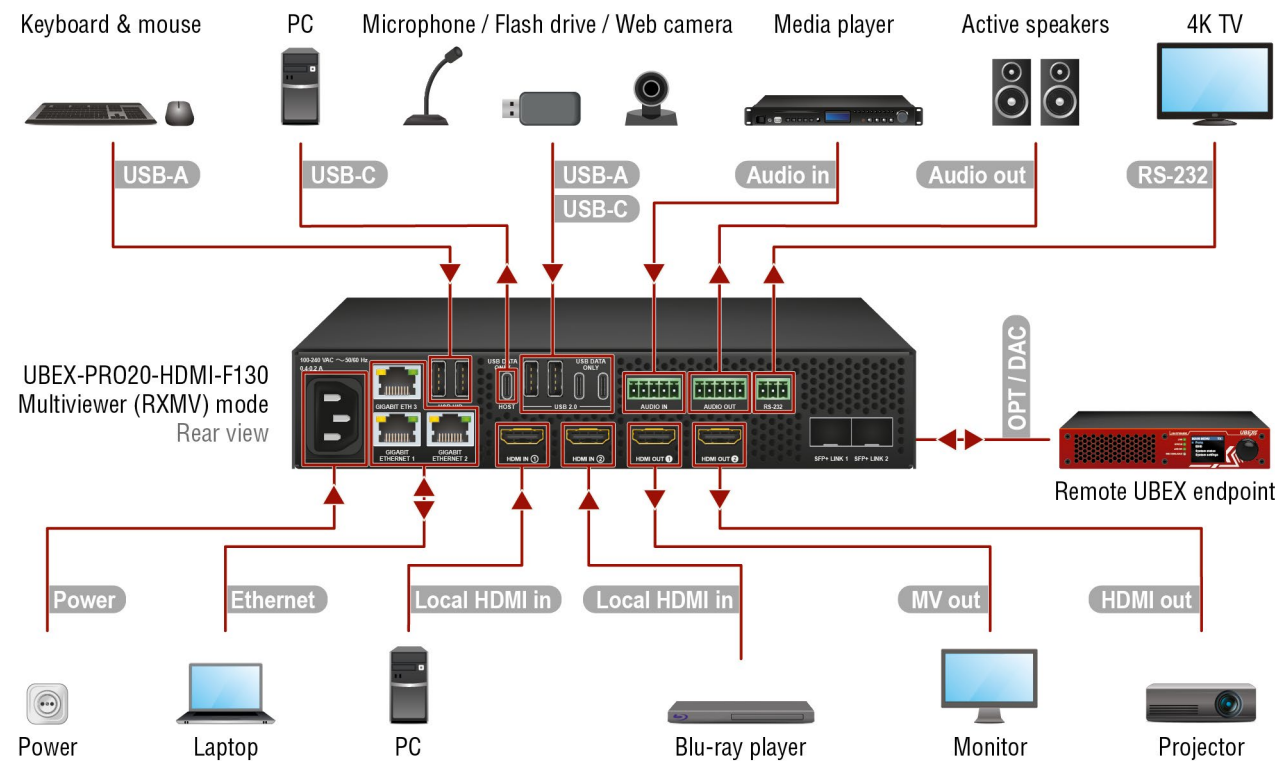

Connections for the F130 model in multiviewer operation mode

Changing the Operation Mode

The operation mode of the UBEX endpoint device can be changed using the following methods:

- via **front panel LCD menu** - see the details in the [Operation Mode](#) section;
- via **Lightware Device Controller (LDC) software** - see the details in the [Status Tab](#) section;
- via **LW3 protocol command** - see the details in the [Set the Operation Mode](#) section.

For all F-series models

OPT DAC	Connect singlemode or multimode (depends on the installed SFP+ modules) fiber optical cables or DAC cables between the two UBEX endpoint devices. The Extender Mode is detected and applied automatically in the device once the connection is established successfully.
Local HDMI in	Connect the local source devices (e.g. PC, Blu-ray player) using the HDMI input 1 and 2 ports by HDMI cables.
MV out	Connect the multiviewer sink device (e.g. monitor) to the HDMI output 1 port by an HDMI cable.
HDMI out	Connect the sink device (e.g. projector) to the HDMI output 2 port by HDMI cable.
Ethernet	Optionally connect the receiver to a LAN in order to control the device.
Power	Connect the power adaptor to the AC input on the multiviewer first, then to the AC power socket.

For F111, F121 and F130 models only

Audio in	Connect an audio source device (e.g. media player) to the audio input connector.
Audio out	Connect an audio sink device (e.g. active speakers) to the audio output connector.
RS-232	Optionally for RS-232 extension: connect the controlled unit (e.g. 4K TV) to the RS-232 port of the device with a serial cable.

For F121 and F130 models only

USB-C	Optionally for USB HID extension: connect the transmitter to the computer by a USB-C cable.
USB-A	Optionally for USB HID extension: connect the USB HID devices to the transmitter (preferably mouse and keyboard).

For F130 model only

USB-A USB-C	USB 2.0 ports: connect the USB devices (e.g. microphone, flash drive, web camera, etc) to the extender for the USB 2.0 extension.
------------------------	---

WARNING! User Ethernet is also transmitted over the SFP+ interface, so be sure not to create a network loop.

INFO: The HDMI input ports can be used as local input ports only when the device is configured as multiviewer.

4.5.5. F110 / F120 Model - USB K+M and Infrared Connections

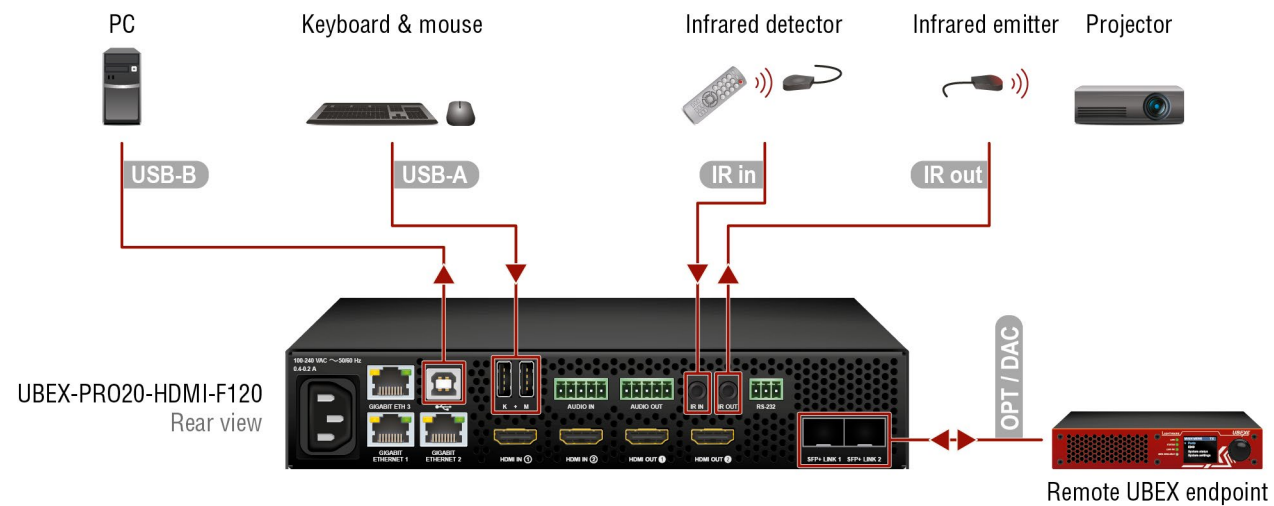

Connections for the F120 model

INFO: The HDMI-, analog audio-, RS-232-, Ethernet-, SFP+ and power-related connections of the F110 and F120 models are the same as the F100 / F111 / F121 / F130 models.

Changing the Mode of the USB HID Ports

The operation mode of the USB HID ports (Local or Remote mode) can be changed using the following methods:

- via **Lightware Device Controller (LDC) software** - see the details in the [USB Tab](#) section;
- via **LW3 protocol command** - see the details in the [Switching the Emulated Port to the Remote Receiver](#) and the [Switching the Local Emulated Port to the Local Receiver](#) sections.

For F110 and F120 models	OPT DAC	Connect singlemode or multimode (depends on the installed SFP+ modules) fiber optical cables or DAC cables between the two UBEX endpoint devices. The Extender Mode is detected and applied automatically in the device once the connection is established successfully.
	IR in	Connect an Infrared detector unit to the IR IN connector for receiving Infrared input signal.
	IR out	Connect an Infrared emitter unit to the IR OUT connector for controlling third-party devices over Infrared signal.
For F120 model only	USB-B	Optionally for USB HID extension: connect the multiviewer to the computer by the USB-B cable.
	USB-A	Optionally for USB HID extension: connect the USB HID devices to the multiviewer (preferably mouse and keyboard).

4.5.6. R-series Endpoints - Transmitter Operation Mode

2xMM-2xDUO and 2xSM-2xDUO

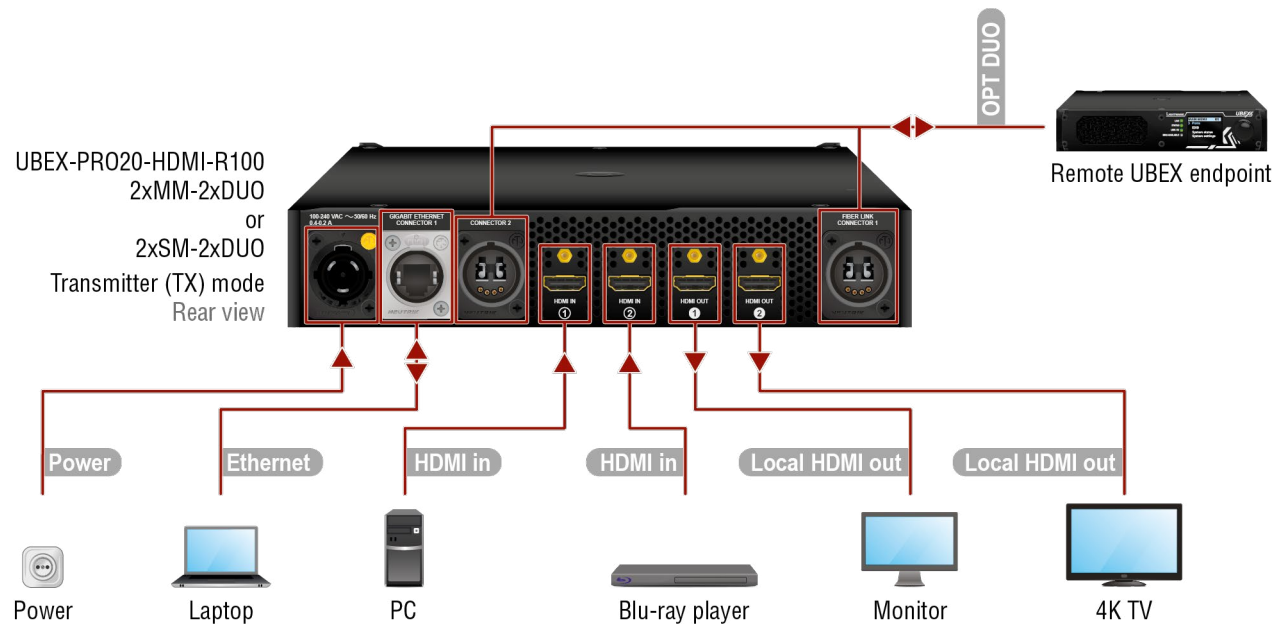

2xMM-QUAD and 2xSM-QUAD



2xSM-BiDi-DUO



For all R-series models	HDMI in	Connect the source devices (e.g. PC, Blu-ray player) using the HDMI input 1 and 2 ports by HDMI cables.
	Local HDMI out	Connect the local sink devices (e.g. monitor, 4K TV) to the HDMI output 1 and 2 ports by HDMI cables. The ports transmit the original streams of the HDMI input ports.
	Ethernet	Optionally connect the transmitter to a LAN in order to control the device.
	Power	Connect the power adaptor to the AC input on the transmitter first, then to the AC power socket.
2xMM-2xDUO	OPT DUO	Connect the device and the remote UBEX endpoint by 2 pcs multimode Neutrik opticalCON DUO or 4 pcs multimode LC fiber optical cables.
2xMM-QUAD	OPT QUAD	Connect the device and the remote UBEX endpoint by a multimode Neutrik opticalCON QUAD fiber optical cable.
2xSM-2xDUO	OPT DUO	Connect the device and the remote UBEX endpoint by 2 pcs singlemode Neutrik opticalCON DUO or 4 pcs singlemode LC fiber optical cables.
2xSM-QUAD	OPT QUAD	Connect the device and the remote UBEX endpoint by a singlemode Neutrik opticalCON QUAD fiber optical cable.
2xSM-BiDi-DUO	OPT BiDi DUO	Connect the device and the remote UBEX endpoint by a singlemode Neutrik opticalCON DUO BiDi or 2 pcs singlemode LC fiber optical cables. The connector does not support the Neutrik opticalCON crossed fiber wiring (A-A; B-B) cable. Please use standard cable (A-B) only.

WARNING! User Ethernet is also transmitted over the fiber optical interface, so be sure not to create a network loop.

ATTENTION: An endpoint model can be connected to the same type of endpoint model, for example a 2xMM-2xDUO can be connected to another 2xMM-2xDUO. Or the 2xSM-BiDi-DUO is compatible with any F-series endpoint device which is built with BiDi SFP+ modules.

INFO: The HDMI output ports can be used as local output ports only when the device is configured as transmitter.

Changing the Operation Mode

The operation mode of the UBEX endpoint device can be changed using the following methods:

- via front panel LCD menu - see the details in the [Operation Mode](#) section;
- via **Lightware Device Controller (LDC) software** - see the details in the [Status Tab](#) section;
- via **LW3 protocol command** - see the details in the [Set the Operation Mode](#) section.

4.5.7. R-series Endpoints - Receiver Operation Mode

2xMM-2xDUO and 2xSM-2xDUO

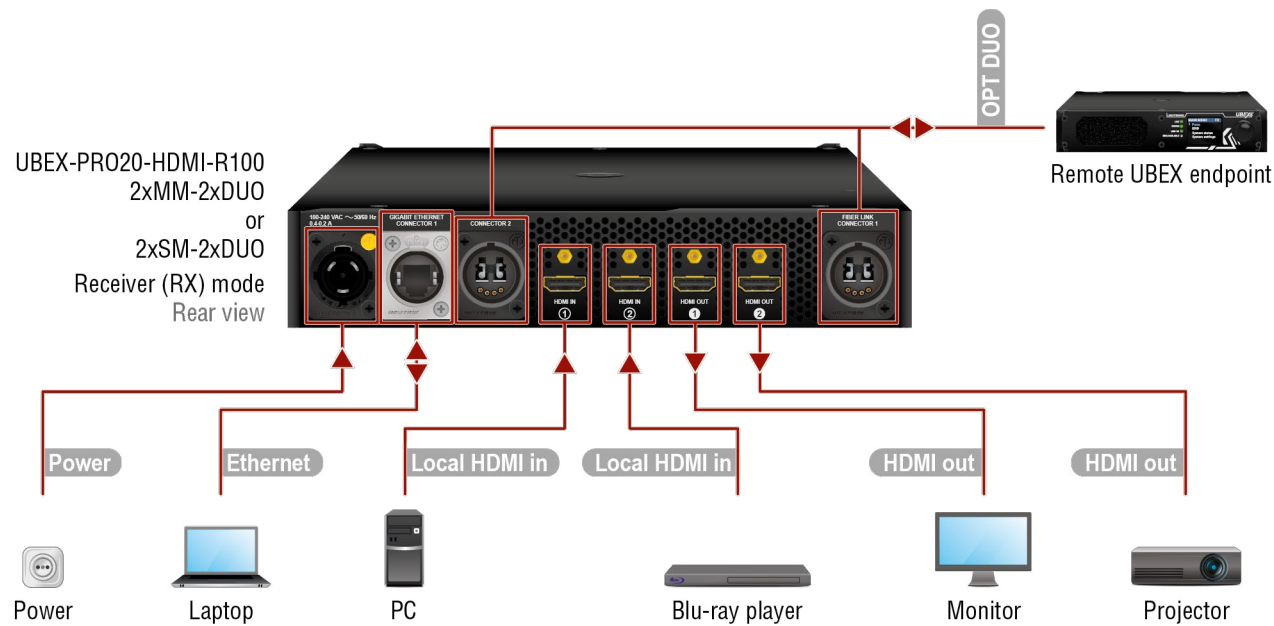

2xMM-QUAD and 2xSM-QUAD



2xSM-BiDi-DUO



For all R-series models	Local HDMI in	Connect the local source devices (e.g. PC, Blu-ray player) using the HDMI input 1 and 2 ports by HDMI cables.
	HDMI out	Connect the sink devices (e.g. monitor, projector) to the HDMI output 1 and 2 ports by HDMI cables.
	Ethernet	Optionally connect the receiver to a LAN in order to control the device.
	Power	Connect the power adaptor to the AC input on the receiver first, then to the AC power socket.
2xMM-2xDUO	OPT DUO	Connect the device and the remote UBEX endpoint by 2 pcs multimode Neutrik opticalCON DUO or 4 pcs multimode LC fiber optical cables.
2xMM-QUAD	OPT QUAD	Connect the device and the remote UBEX endpoint by a multimode Neutrik opticalCON QUAD fiber optical cable.
2xSM-2xDUO	OPT DUO	Connect the device and the remote UBEX endpoint by 2 pcs singlemode Neutrik opticalCON DUO or 4 pcs singlemode LC fiber optical cables.
2xSM-QUAD	OPT QUAD	Connect the device and the remote UBEX endpoint by a singlemode Neutrik opticalCON QUAD fiber optical cable.
2xSM-BiDi-DUO	OPT BiDi DUO	Connect the device and the remote UBEX endpoint by a singlemode Neutrik opticalCON DUO BiDi or 2 pcs singlemode LC fiber optical cables. The connector does not support the Neutrik opticalCON crossed fiber wiring (A-A; B-B) cable. Please use standard cable (A-B) only.

WARNING! User Ethernet is also transmitted over the fiber optical interface, so be sure not to create a network loop.

ATTENTION: An endpoint model can be connected to the same type of endpoint model, for example a 2xMM-2xDUO can be connected to another 2xMM-2xDUO. Or the 2xSM-BiDi-DUO is compatible with any F-series endpoint device which is built with BiDi SFP+ modules.

INFO: The HDMI input ports can be used as local input ports only when the device is configured as receiver.

Changing the Operation Mode

The operation mode of the UBEX endpoint device can be changed using the following methods:

- via front panel LCD menu - see the details in the [Operation Mode](#) section;
- via **Lightware Device Controller (LDC) software** - see the details in the [Status Tab](#) section;
- via **LW3 protocol command** - see the details in the [Set the Operation Mode](#) section.

4.5.8. R-series Endpoints - Transceiver Operation Mode

2xMM-2xDUO and 2xSM-2xDUO

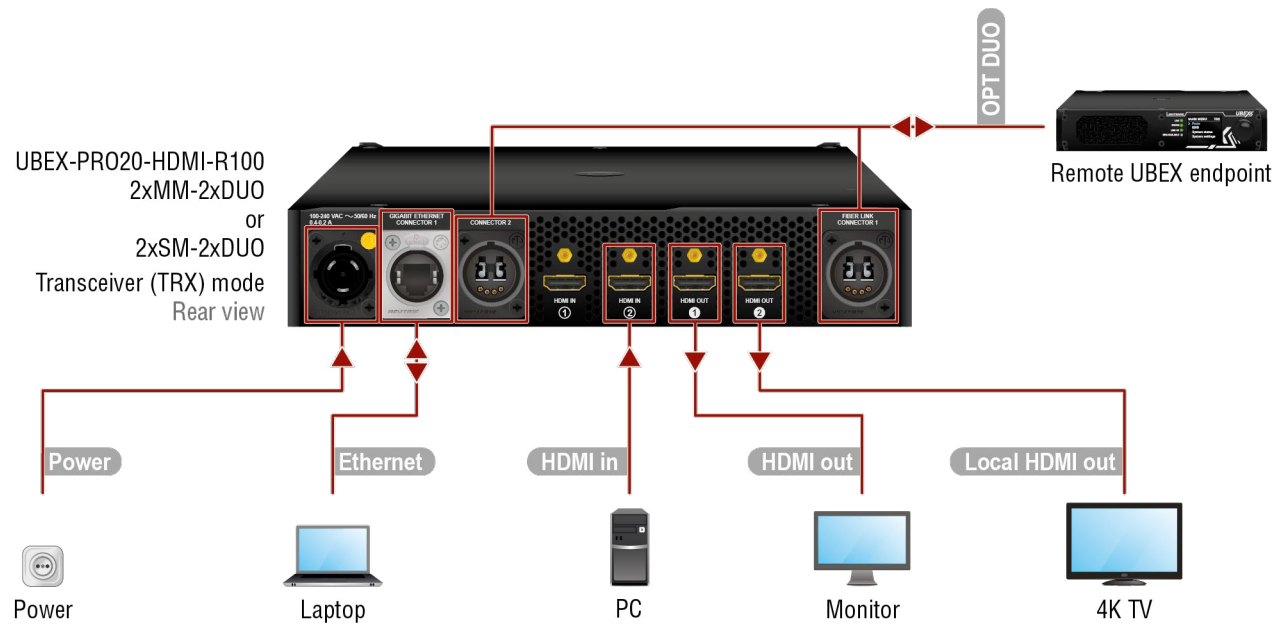

2xMM-QUAD and 2xSM-QUAD



2xSM-BiDi-DUO



For all R-series models	HDMI in	Connect and the source device (e.g. PC) using the HDMI input 2 port by an HDMI cable.
	HDMI out	Connect a sink device (e.g. monitor) to the HDMI output 1 port by an HDMI cable.
	Local HDMI out	Connect a local sink device (e.g. 4K TV) to the HDMI output 2 port by an HDMI cable. The port transmit the original stream of the HDMI in 2 port.
	Ethernet	Optionally connect the transceiver to a LAN in order to control the device.
	Power	Connect the power adaptor to the AC input on the transceiver first, then to the AC power socket.
2xMM-2xDUO	OPT DUO	Connect the device and the remote UBEX endpoint by 2 pcs multimode Neutrik opticalCON DUO or 4 pcs multimode LC fiber optical cables.
2xMM-QUAD	OPT QUAD	Connect the device and the remote UBEX endpoint by a multimode Neutrik opticalCON QUAD fiber optical cable.
2xSM-2xDUO	OPT DUO	Connect the device and the remote UBEX endpoint by 2 pcs singlemode Neutrik opticalCON DUO or 4 pcs singlemode LC fiber optical cables.
2xSM-QUAD	OPT QUAD	Connect the device and the remote UBEX endpoint by a singlemode Neutrik opticalCON QUAD fiber optical cable.
2xSM-BiDi-DUO	OPT BiDi DUO	Connect the device and the remote UBEX endpoint by a singlemode Neutrik opticalCON DUO BiDi or 2 pcs singlemode LC fiber optical cables. The connector does not support the Neutrik opticalCON crossed fiber wiring (A-A; B-B) cable. Please use standard cable (A-B) only.

WARNING! User Ethernet is also transmitted over the fiber optical interface, so be sure not to create a network loop.

ATTENTION: An endpoint model can be connected to the same type of endpoint model, for example a 2xMM-2xDUO can be connected to another 2xMM-2xDUO. Or the 2xSM-BiDi-DUO is compatible with any F-series endpoint device which is built with BiDi SFP+ modules.

INFO: The HDMI input 1 port cannot accept AV signal when the device is configured as transceiver.

Changing the Operation Mode

The operation mode of the UBEX endpoint device can be changed using the following methods:

- via **front panel LCD menu** - see the details in the [Operation Mode](#) section;
- via **Lightware Device Controller (LDC) software** - see the details in the [Status Tab](#) section;
- via **LW3 protocol command** - see the details in the [Set the Operation Mode](#) section.

4.5.9. R-series Endpoints - Multiviewer Operation Mode

2xMM-2xDUO and 2xSM-2xDUO

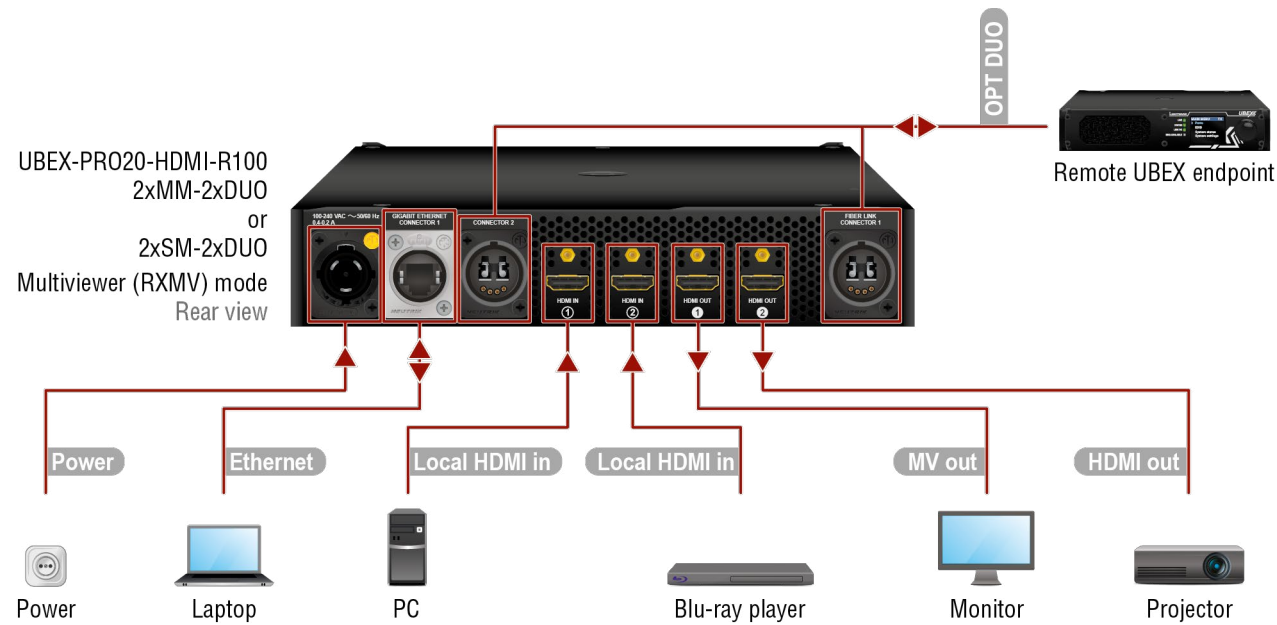

2xMM-QUAD and 2xSM-QUAD



2xSM-BiDi-DUO



For all R-series models	
Local HDMI in	Connect the local source devices (e.g. PC, Blu-ray player) using the HDMI input 1 and 2 ports by HDMI cables.
MV out	Connect the multiviewer sink device (e.g. monitor) to the HDMI output 1 port by an HDMI cable.
HDMI out	Connect the sink device (e.g. projector) to the HDMI output 2 port by an HDMI cable.
Ethernet	Optionally connect the receiver to a LAN in order to control the device.
Power	Connect the power adaptor to the AC input on the receiver first, then to the AC power socket.
2xMM-2xDUO	OPT DUO: Connect the device and the remote UBEX endpoint by 2 pcs multimode Neutrik opticalCON DUO or 4 pcs multimode LC fiber optical cables.
2xMM-QUAD	OPT QUAD: Connect the device and the remote UBEX endpoint by a multimode Neutrik opticalCON QUAD fiber optical cable.
2xSM-2xDUO	OPT DUO: Connect the device and the remote UBEX endpoint by 2 pcs singlemode Neutrik opticalCON DUO or 4 pcs singlemode LC fiber optical cables.
2xSM-QUAD	OPT QUAD: Connect the device and the remote UBEX endpoint by a singlemode Neutrik opticalCON QUAD fiber optical cable.
2xSM-BiDi-DUO	OPT BiDi DUO: Connect the device and the remote UBEX endpoint by a singlemode Neutrik opticalCON DUO BiDi or 2 pcs singlemode LC fiber optical cables. The connector does not support the Neutrik opticalCON crossed fiber wiring (A-A; B-B) cable. Please use standard cable (A-B) only.

WARNING! User Ethernet is also transmitted over the fiber optical interface, so be sure not to create a network loop.

ATTENTION: An endpoint model can be connected to the same type of endpoint model, for example a 2xMM-2xDUO can be connected to another 2xMM-2xDUO. Or the 2xSM-BiDi-DUO is compatible with any F-series endpoint device that is built with BiDi SFP+ modules.

INFO: The HDMI input ports can be used as local input ports only when the device is configured as receiver.

Changing the Operation Mode

The operation mode of the UBEX endpoint device can be changed using the following methods:

- via **front panel LCD menu** - see the details in the [Operation Mode](#) section;
- via **Lightware Device Controller (LDC) software** - see the details in the [Status Tab](#) section;
- via **LW3 protocol command** - see the details in the [Set the Operation Mode](#) section.

4.6. SFP+ Slot Connection

INFO: The SFP+ slots support the hot swap connection - the endpoint devices do not need to be powered off before inserting or removing SFP+ modules or DAC cables.

4.6.1. Installation of SFP+ Modules

UBEX endpoint devices use SFP+ modules for the fiber optical connections. The optical modules can be changed based on the current application of the extender: it can be singlemode or multimode, or BiDi modules, up to 10 GbE signal transmission.

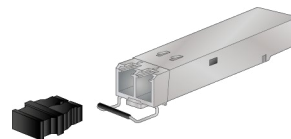

INFO: It is recommended to install 2x 10 GbE SFP+ modules per endpoint in the case of HDMI 2.0 (4K@60 Hz 4:4:4) signal transmission.

Inserting and Cabling of SFP+ Modules

- Step 1.** Put up on the handle bar.
- Step 2.** Connect the module to the to one of the SFP+ port slot.
- Step 3.** Connect the LC connectors / RJ45 Ethernet cables to the SFP+ modules.

INFO: The SFP+ modules have a side that clips to the connector on the port of the switch, and is designed to prevent the module from being inserted the wrong way into the port. Do NOT force the module into the port.

Removing SFP+ Modules

- Step 1.** Disconnect the LC connectors / RJ45 Ethernet cables from the SFP+ module.
- Step 2.** Pull down on the handle bar.
- Step 3.** Gently slide out the SFP+ module from the slot.

4.6.2. Installation of DAC Cables

UBEX endpoint devices can be connected via DAC (Direct Attach Copper) cables as well. The cable type must support 10 GbE signal transmission.

INFO: It is recommended to install 2x 10 GbE DAC cables in the case of HDMI 2.0 (4K@60 Hz 4:4:4) signal transmission.



Inserting the DAC Cables

- Step 1.** Push the plug of the DAC cable to one of the SFP+ port slot of the local endpoint to stop.
- Step 2.** Push the other plug of the DAC cable to one of the SFP+ port slot of remote endpoint to stop.

Removing the DAC Cables

Pull the handle bar of the plug and gently slide out the cable from the slot.

4.7. Fiber Optical Cable Connections

The section describes how to connect the fiber optical cables between two SFP+ modules or between two Neutrik opticalCON connectors in case of F and R-series endpoint devices.

4.7.1. Connection between SFP+ Modules

Affected models:

- UBEX-PRO20-HDMI-F100
- UBEX-PRO20-HDMI-F110
- UBEX-PRO20-HDMI-F111
- UBEX-PRO20-HDMI-F120
- UBEX-PRO20-HDMI-F121
- UBEX-PRO20-HDMI-F130

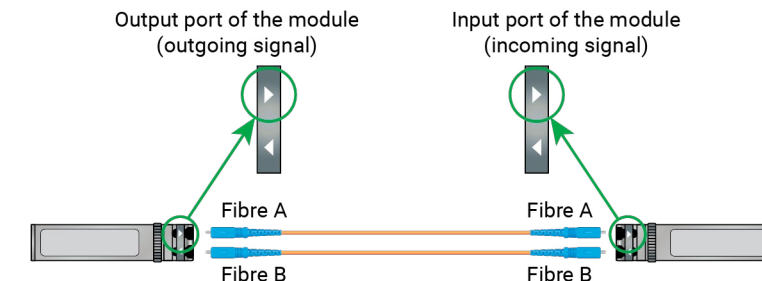

Connect multimode or singlemode fiber optical cables with LC simplex connectors to the SFP+ modules like in the illustration on the right.

ATTENTION: Always check the direction of the optical signal. The TX port of the module is highlighted with an arrow pointing outward from the device, the RX port of the module is highlighted with another arrow pointing inward to the device.

4.7.2. Connection between BiDi (Bidirectional) SFP+ Modules

Affected models:

- UBEX-PRO20-HDMI-F100
- UBEX-PRO20-HDMI-F110
- UBEX-PRO20-HDMI-F111
- UBEX-PRO20-HDMI-F120
- UBEX-PRO20-HDMI-F121
- UBEX-PRO20-HDMI-F130

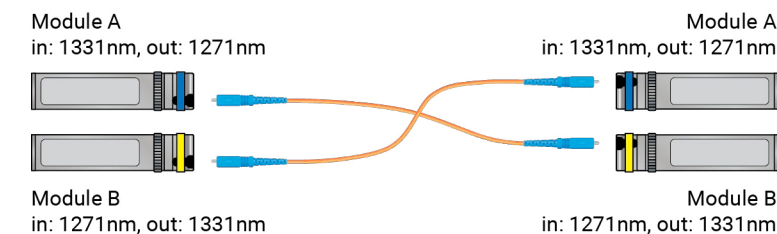

Connect multimode or singlemode fiber optical cables with LC simplex connectors to the BiDi SFP+ modules like in the illustration on the right.

ATTENTION: The Module A must be connected to the Module B. Always check the **wavelength** of the BiDi modules. If the wavelengths are different, the cabling might be also different and the modules shall be connected **across**.

4.7.3. Connection between Neutrik opticalCON DUO Connectors

Affected models:

- UBEX-PRO20-HDMI-R100 2xMM-2xDUO
- UBEX-PRO20-HDMI-R100 2xSM-2xDUO

Connect multimode or singlemode fiber optical cables with LC simplex connectors to the Neutrik opticalCON DUO connectors like in the illustration on the right.

ATTENTION: Always check the direction of the optical signal. **The Port A must be connected to the Port B.**

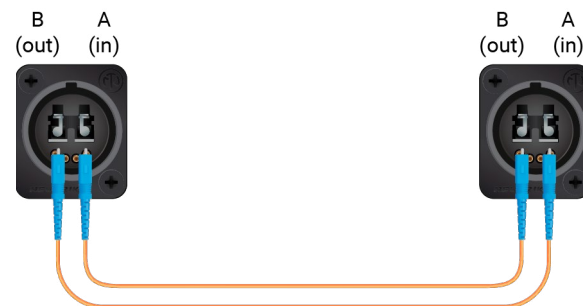

4.7.4. Connection between Neutrik opticalCON DUO BiDi Connectors

Affected model:

- UBEX-PRO20-HDMI-R100 2xSM-BiDi-DUO

Connect multimode or singlemode fiber optical cables with LC simplex connectors to the Neutrik opticalCON DUO connectors like in the illustration on the right.

ATTENTION: Always check the direction of the optical signal. **The Port A must be connected to the Port B.**

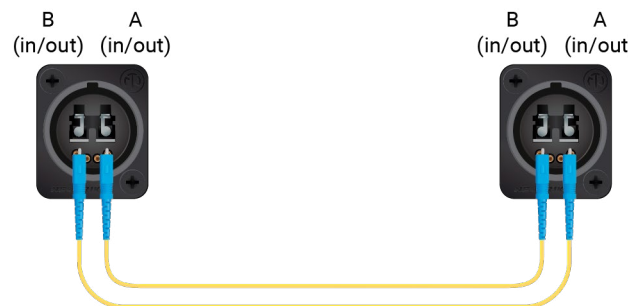

4.8. Copper Cable Connections

The section describes how to connect the CATx copper Ethernet cables **between two SFP+ to RJ45 modules** in case of F-series endpoint devices.

Affected models:

- UBEX-PRO20-HDMI-F100
- UBEX-PRO20-HDMI-F110
- UBEX-PRO20-HDMI-F111
- UBEX-PRO20-HDMI-F120
- UBEX-PRO20-HDMI-F121
- UBEX-PRO20-HDMI-F130

Connect CAT6A or CAT7 (AWG24 or higher category) 10G Ethernet cable to the SFP+ to RJ45 modules.

ATTENTION: Always apply **equal length** copper cables for both SFP+ to RJ45 modules in case of 20G signal transmission. Different cable lengths may cause data package loss.

INFO: In case of SFP+ to RJ45 module installation, the endpoint device sets the **cooling fans** to (minimum) **2500 rpm** automatically.

TIPS AND TRICKS: AWG number shows the quality of the copper cable. The number is smaller, the quality of the cable is better and its resistance is even smaller. Smaller resistance makes possible applying longer cable.

4.9. Connection between F-series and R-series Endpoints

The UBEX F-series endpoint devices are built with SFP+ ports, the R-series devices are built with Neutrik opticalCON DUO and QUAD fiber optical connections. This section is about how to establish connection between an F and R-series endpoint device over the different type of connectors.

4.9.1. SFP+ to Neutrik opticalCON DUO

This method works between the following endpoint models:

F-series endpoint model		R-series endpoint model
UBEX-PRO20-HDMI-F100	↔	UBEX-PRO20-HDMI-R100 2xMM-2xDUO
UBEX-PRO20-HDMI-F110		
UBEX-PRO20-HDMI-F111		
UBEX-PRO20-HDMI-F120		UBEX-PRO20-HDMI-R100 2xSM-2xDUO
UBEX-PRO20-HDMI-F121		
UBEX-PRO20-HDMI-F130		

Connecting Steps

- Step 1.** Insert 2 pcs of 10GbE singlemode/multimode SFP+ transceiver modules to the SFP+ slots of the F100 / F110 / F111 / F120 / F121 / F130 endpoint device.
- Step 2.** You need 2 pcs singlemode/multimode Neutrik opticalCON DUO series connectors and 2 pcs singlemode/multimode fiber optical patch cables with LC duplex connectors. Connect the SFP+ modules and the back of the Neutrik opticalCON DUO connector by the patch cables (a standard LC duplex connector can be found on the back of the Neutrik opticalCON DUO connector).

TIPS AND TRICKS: Extra Neutrik connectors can be assembled to a blank 1U high rack shelf which can make easier the mounting of the connectors and the cabling.



Step 3. Establish connection between the additional Neutrik opticalCON DUO connectors and the R100 endpoint device using 2 pcs of singlemode/multimode Neutrik opticalCON DUO series cables. The following figure shows the correct cabling layout of optical connectors on the R100 endpoint device:

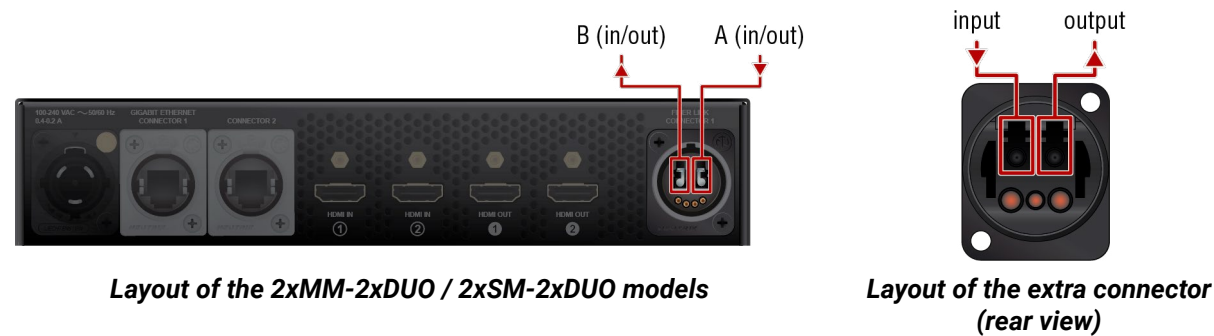

Layout of the 2xMM-2xDUO / 2xSM-2xDUO models

Layout of the extra connector (rear view)

ATTENTION: Always be sure that the fiber optical mode of the entire fiber optical equipment (SFP+ modules, LC patch cables, Neutrik connectors, and cables) and R100 endpoint device is the same. Connecting to the 2xMM-2xDUO model requires **multimode** equipment, connecting to the 2xSM-2xDUO model requires **singlemode** equipment.

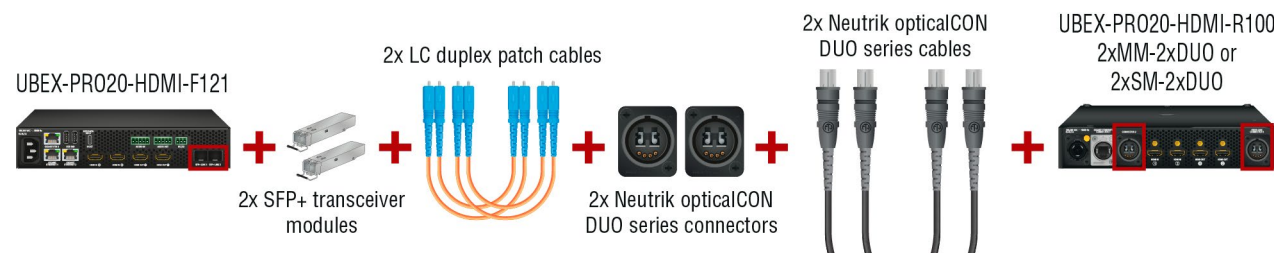

Required fiber optical equipment for connecting an F120 and an R100 DUO endpoint device

INFO: This method does not work in the case of using **DAC cables** in the F-series endpoint device.

4.9.2. SFP+ to Neutrik opticalCON QUAD

This method works between the following endpoint models:

F-series endpoint model		R-series endpoint model
UBEX-PRO20-HDMI-F100	↔	UBEX-PRO20-HDMI-R100 2xMM-QUAD
UBEX-PRO20-HDMI-F110		
UBEX-PRO20-HDMI-F111		
UBEX-PRO20-HDMI-F120		
UBEX-PRO20-HDMI-F121		
UBEX-PRO20-HDMI-F130		UBEX-PRO20-HDMI-R100 2xSM-QUAD

Connecting Steps

- Step 1.** Insert 2 pcs of 10GbE singlemode/multimode SFP+ transceiver modules to the SFP+ slots of the F100 / F110 / F111 / F120 / F121 / F130 endpoint device.
- Step 2.** You need a singlemode/multimode Neutrik opticalCON QUAD series connector and 2 pcs singlemode/multimode fiber optical patch cables with LC duplex connectors. Connect the SFP+ modules and the back of the Neutrik opticalCON QUAD connector by the patch cables (2 pcs of standard LC duplex connectors can be found on the back of the Neutrik opticalCON QUAD connector).



TIPS AND TRICKS: Extra Neutrik connectors can be assembled to a blank 1U high rack shelf which can make the mounting of the connection and the cabling easier.

Step 3. Establish connection between the additional Neutrik opticalCON QUAD connector and the R100 endpoint device using a singlemode/multimode Neutrik opticalCON QUAD series cable. The following figure shows the correct cabling layout of the extra QUAD optical connector (the rear side of the extra connector can be seen on the right).

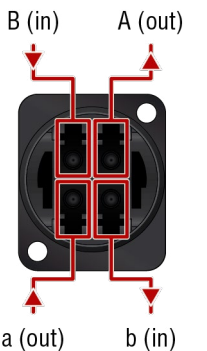

ATTENTION: Always be sure that the fiber optical mode of the entire fiber optical equipment (SFP+ modules, LC patch cables, Neutrik connectors, and cables) and R100 endpoint device is the same. Connecting to the **2xMM-QUAD** model requires **multimode** equipment, connecting to the **2xSM-QUAD** model requires **singlemode** equipment.

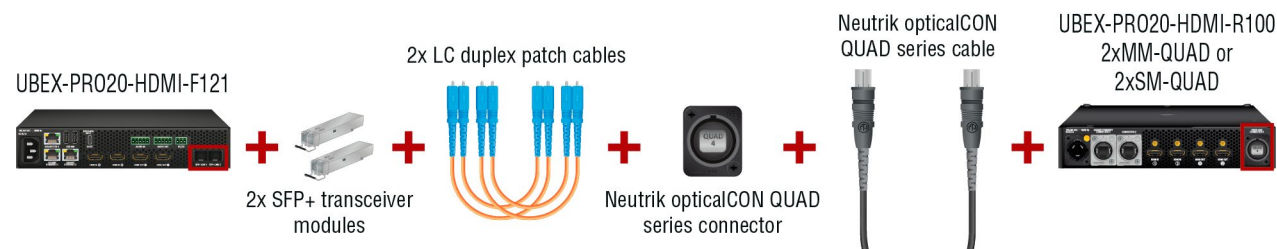

Required fiber optical equipment for connecting an F120 and an R100 QUAD endpoint device

INFO: This method does not work in the case of using **DAC cables** in the F-series endpoint device.

4.9.3. SFP+ BiDi to Neutrik opticalCON DUO BiDi

This method works between the following endpoint models:

F-series endpoint model	R-series endpoint model
UBEX-PRO20-HDMI-F100	 UBEX-PRO20-HDMI-R100 2xSM-BiDi-DUO
UBEX-PRO20-HDMI-F110	
UBEX-PRO20-HDMI-F111	
UBEX-PRO20-HDMI-F120	
UBEX-PRO20-HDMI-F121	
UBEX-PRO20-HDMI-F130	

Connecting Steps

- Step 1.** Insert 2 pcs of 10GbE singlemode SFP+ BiDi transceiver modules to the SFP+ slots of the F100 / F110 / F111 / F120 / F121 / F130 endpoint device.
- Step 2.** You need a singlemode/multimode Neutrik opticalCON DUO BiDi connector and 2 pcs singlemode/multimode fiber optical patch cables with LC simplex connectors. Connect the SFP+ modules and the back of the Neutrik opticalCON DUO connector by the patch cables (a standard LC duplex connector can be found on the back of the Neutrik opticalCON DUO connector).



TIPS AND TRICKS: Extra Neutrik connectors can be assembled to a blank 1U high rack shelf which can make the mounting of the connection and the cabling easier.

Step 3. Establish connection between the additional Neutrik opticalCON DUO connector and the R100 endpoint device using a singlemode/multimode Neutrik opticalCON DUO BiDi cable. The following figure shows the correct cabling layout of optical connectors on the R100 endpoint device:

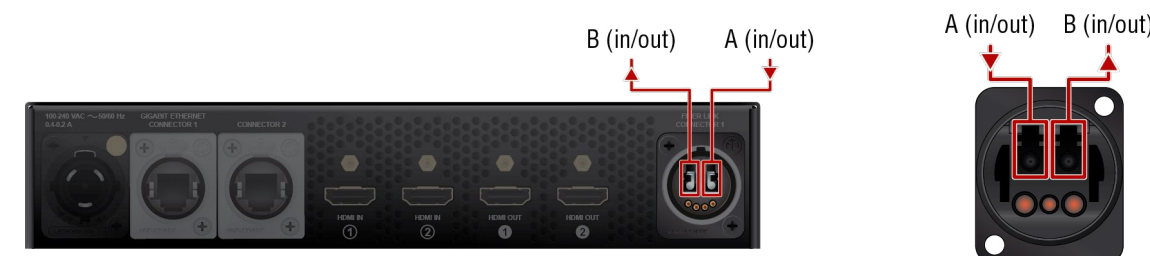

Layout of the 2xSM-BiDi DUO model (rear view)

Layout of the extra connector (rear view)

SFP+ modules behind the Neutrik opticalCON DUO connector		
Channel	Type of the SFP+ module	Wavelength
A	Finisar FTLX2072D327	input: 1331 nm; output: 1271 nm
B	Finisar FTLX2072D333	input: 1271 nm; output: 1331 nm

ATTENTION: The 2xSM-BiDi-DUO model does not support the Neutrik opticalCON DUO crossed fiber wiring (A-A; B-B) cables. Please **use standard (A-B)** cables only.

ATTENTION: Always be sure that the fiber optical mode of the entire fiber optical equipment (SFP+ modules, LC patch cables, Neutrik connectors, and cables) and R100 endpoint device is the same. Connecting to the **2xSM-BiDi-DUO** model requires **singlemode** equipment.

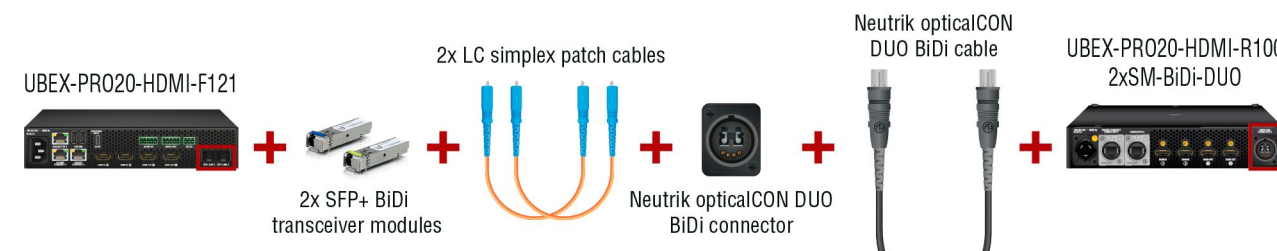

Required fiber optical equipment for connecting an F120 and an R100 2xSM-BiDi-DUO endpoint device

INFO: This method does not work in the case of using **DAC cables** in the F-series endpoint device.

4.10. Startup of the System

The following section describes the startup of the UBEX extender system step-by-step from the beginning to the displayed video on the sink devices.

ATTENTION: Before powering on the system, please check the [Connections](#) section to be sure all installation steps are met with the connection requirements.

4.10.1. Switch on the Devices

Power on the UBEX endpoints, the source, and the sink devices connected to the extenders.

INFO: After the booting procedure of the UBEX extenders, the last configuration is loaded automatically.

4.10.2. Configure the Operation Mode

All endpoint devices are manufactured as transmitter (TX) by default. Set up the **operation mode** for the endpoints to be used as receivers or transceivers with the **Front panel LCD menu**. See the details in the [Operation Mode](#) section.

4.10.3. Establish the Connection with the UBEX Extenders

Establish the connection between one of the UBEX extenders and the controller device via LAN network. It is highly recommended to connect one of the extenders due to the following reasons:

- The two UBEX endpoints are visible for each other in the case of correct SFP+ link connection.
- User Ethernet is also transmitted over the SFP+ interface, so be sure not to create a network loop.

Network Settings

Check the network settings of the UBEX extenders. You can find the factory default settings of the endpoint in the [Factory Default Settings](#) section. The network settings can be changed using two different methods:

- via **LCD menu** - see the details in the [Network](#) section.
- via **LDC software**, in the **Device discovery window** - see the details in the [Establishing the Connection](#) section.

Lightware Device Controller Software

All required settings can be done by control software, the Lightware Device Controller (LDC). See all the details about it in the [Software Control - Lightware Device Controller](#) chapter.

Discovering the Device

Step 1. Open the LDC software. The **Device discovery** window will launch automatically to discover all available Lightware devices on the network where the controller device is connected to.

Step 2. Select the endpoint device that you want to connect to and click on the green **Connect** button.

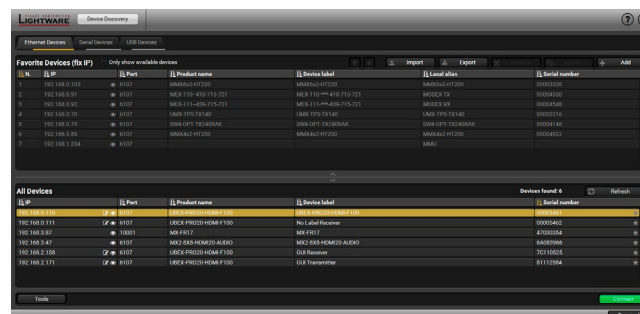

4.10.4. Check the Signal Status

The **Crosspoint** menu in the LDC software displays all important information about the incoming, transmitting, and outgoing HDMI signals. For more detailed information, see the [Video Crosspoint Menu](#) section.

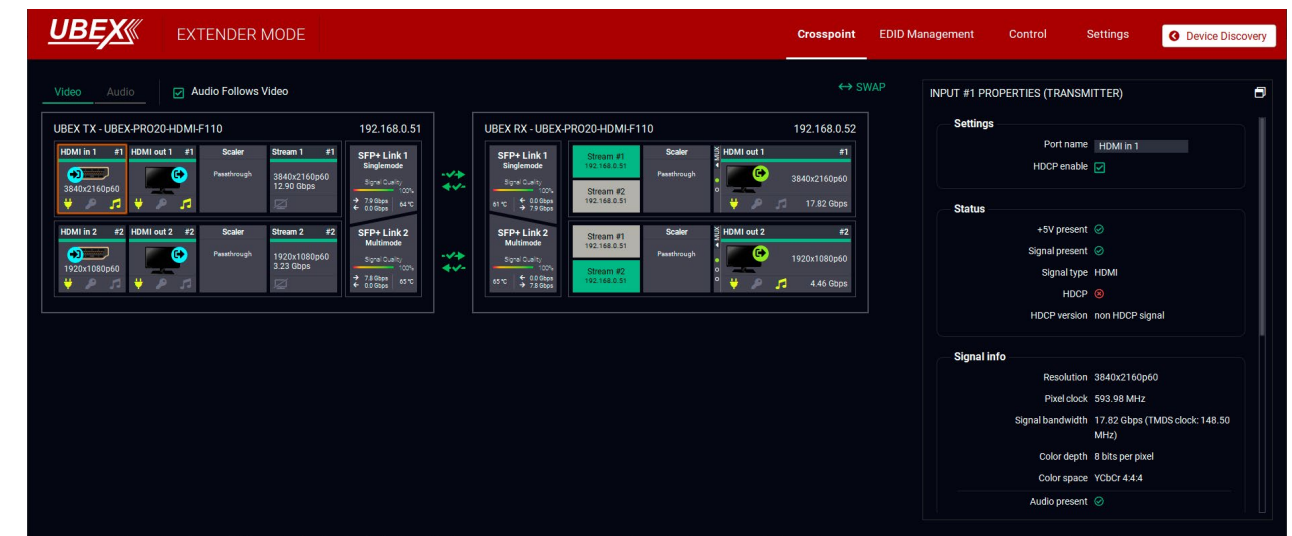

The video crosspoint menu in the LDC software for TX-RX pair

Transmitter (UBEX TX) Side

- Step 1.** Check the HDMI signal status on the **HDMI in 1 and 2 input ports** - if the **signal status indicator** is green, the signal is present; if it is grey, there is no incoming signal on the port.
- Step 2.** Check the HDMI signal status on the **HDMI out 1 and 2 local output ports** - if the **signal status indicator** is green, the signal is present and sink device is connected; if it is grey, there is no transmitted signal on the port.
- Step 3.** Check the video streams in the **Stream 1 and 2 panels** - if the **signal status indicator** is green, the signal is present; if it is grey, there is no incoming signal on the port. Also check the **enable status** of the stream on the stream settings panel.

Receiver (UBEX RX) Side

- Step 1.** Check the **Stream switcher** - the desired stream is switched to the HDMI output port.
- Step 2.** Check the HDMI signal status on the **HDMI out 1 and 2 output ports** - if the **signal status indicator** is green, the signal is present and sink device is connected; if it is grey, there is no transmitted signal on the port.

Transceiver (UBEX TRX) Side

- Step 1.** Check the HDMI signal status on the **HDMI in 2 input port** - if the **signal status indicator** is green, the signal is present; if it is grey, there is no incoming signal on the port.
- Step 2.** Check the HDMI signal status on the **HDMI out 1 output port** - if the **signal status indicator** is green, the signal is present and sink device is connected; if it is grey, there is no transmitted signal on the port.

SFP+ Links

Check the connection status of the SFP+ links:

- **Green arrows** mean connection is established and TCP/IP packages are transmitted successfully.
- **Amber arrows** mean connection is established but error happened during the transmission of the TCP/IP packages - check the SFP+ connection.
- **Red arrows** mean no connection is established between the endpoint devices.

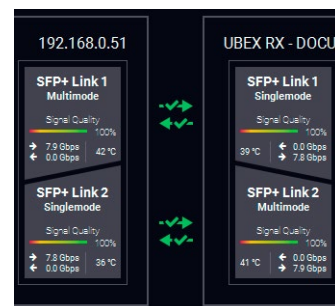

4.10.5. Set the Source MUX Settings

DEFINITION: The source multiplexer (**Source MUX**) makes routing several different source signals to the HDMI output ports available. The setting is available only on the output ports of the receiver and transceiver operation modes. Different types of sources are available for the different output ports.

Click on the left side of the output port tile to access the MUX settings. The available options are the following:

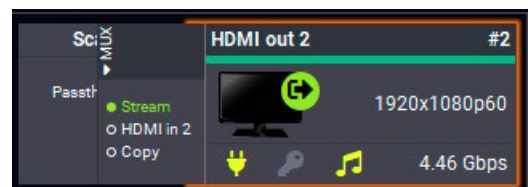

Receiver (UBEX RX) Side

For HDMI out 1

- **Stream** - The source signal is the stream received **via the SFP+ links** from the remote endpoint device;
- **HDMI in 1** - The source signal is the stream received **via the local HDMI in 1** port.

For HDMI out 2

- **Stream** - The source signal is the stream received **via the SFP+ links** from the remote endpoint device;
- **HDMI in 2** - The source signal is the stream received **via the local HDMI in 2** port.
- **Copy** - The receiver is able to **copy the signal of the HDMI out 1** port. This is the **COPY** function.

Transceiver (UBEX TRX) Side

For HDMI out 2

- **HDMI in 2** - The source signal is the stream received **via the local HDMI in 2** port.
- **Copy** - The receiver is able to **copy the signal of the HDMI out 1** port. This is the **COPY** function.

4.10.6. Set the HDCP Settings

Check the HDCP settings both on the input and output ports. For more details about the HDCP technology see the [HDCP Management](#) section.

- Open the HDMI in 1 and 2 port properties panel on the transmitter or transceiver side and check the **HDCP enable** setting. Put a tick to enable HDCP capability on the port.
- Open the HDMI out 1 and 2 local output port properties panels on the transmitter or transceiver side and check the **HDCP mode** setting.
- Open the HDMI out 1 and 2 output port properties panels on the receiver or transceiver side and check the **HDCP mode** setting.

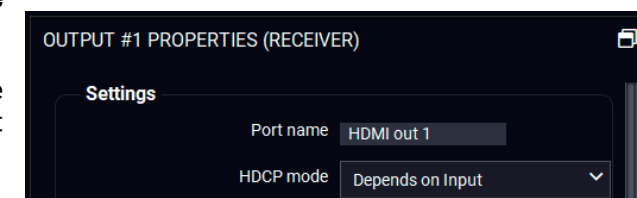
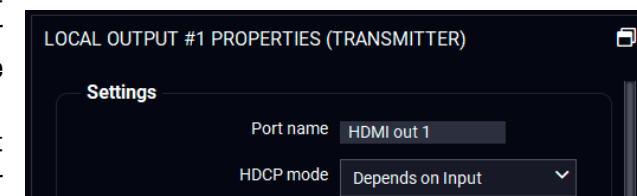
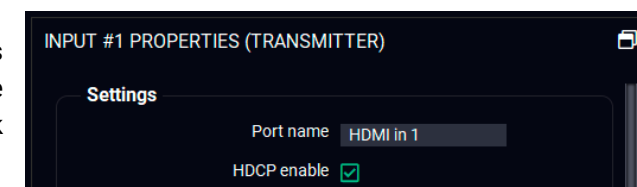

INFO: UBEX extenders always authenticate the highest version of HDCP-encryption and cannot force the lower version.

4.10.7. Emulate the Correct EDID

Emulate the right EDID to the HDMI input ports of the transmitter/transceiver. The EDID must be set according to the desired resolution / refresh rate of the stream.

INFO: You can find detailed information about the EDID Management menu of the LDC software in the [EDID Management Menu](#) section; about the technology in general, please read the [EDID Management](#) section.

Navigate to the **EDID Management** menu in the LDC software. Select the **Emulated** EDIDs on the right side panel, and select **Factory** EDIDs on the left side panel. See the entire list of the pre-installed factory EDIDs in the [Factory EDID List](#) section.

Example**For HDMI in 1**

In our example the incoming signal on the HDMI in 1 port is 4K UHD 60 Hz (3840x2160p@60Hz 4:4:4).

Select the F137 memory address on the left side and also select the E1 EDID memory slot on the Emulated side. Click on the **Transfer** button (the arrow in the middle) to emulate the selected EDID.

For HDMI in 2

In our example the HDMI in 2 port receives 1080p60 Hz signal (1920x1080p@60Hz).

Select the F48 memory track on the left side and also select the E2 EDID memory slot on the Emulated side. Click on the **Transfer** button (the arrow in the middle) to emulate the selected EDID.

Memory	Manufac.	Resolution	Audio	Monitor Name	Memory	Manufac.	Resolution	Audio	Monitor Name	Sour...
F121	LWR	1440x1080p59.91Hz	2chLPCM	H1440x1080p60	E1 (HDMI in 1)	LWR	3840x2160p60.00Hz	2chLPCM	HUHDp60_444	F137
F122	LWR	2560x2048p59.98Hz	2chLPCM	H2560x2048p60	E2 (HDMI in 2)	LWR	1920x1080p60.00Hz	2chLPCM,8chLP...	Univ_HDMI_ALL	F48
F123	LWR	1280x800p59.91Hz	2chLPCM	H1280x800p60						
F124	LWR	1440x900p59.90Hz	2chLPCM	H1440x900p60						
F125	LWR	1366x768p60.00Hz	2chLPCM	H1366x768p60						
F126	LWR	1600x900p59.98Hz	2chLPCM	H1600x900p60						
F127	LWR	2048x1080p60.00Hz	2chLPCM	H2048x1080p60						
F128	LWR	2560x1080p60.00Hz	2chLPCM	H2560x1080p60						
F129	LWR	3440x1440p24.99Hz	2chLPCM	H3440x1440p25						
F130	LWR	3440x1440p29.99Hz	2chLPCM	H3440x1440p30						
F131	LWR	4096x2160p25.00Hz	2chLPCM	H4096x2160p25						
F132	LWR	4096x2160p30.00Hz	2chLPCM	H4096x2160p30						
F133	LWR	4096x2160p60.00Hz	2chLPCM	4Kp60_420						
F134	LWR	3440x1440p23.99Hz	2chLPCM	H3440x1440p24						
F135	LWR	4096x2160p24.00Hz	2chLPCM	H4096x2160p24						
F136	LWR	3840x2400p29.99Hz	2chLPCM	H3840x2400p30						
F137	LWR	3840x2160p60.00Hz	2chLPCM	HUHDp60_444						
F138	LWR	3840x2160p50.00Hz	2chLPCM	HUHDp50_444						
F139	LWR	3840x2160p60.00Hz	2chLPCM	H2_UHD_PCM						
F140	LWR	3840x2160p60.00Hz	2chLPCM,8chLPCM,DD...	H2_UHD_ALL						
F141	LWR	4096x2160p60.00Hz	2chLPCM	H4Kp60_444						
F142	LWR	4096x2160p50.00Hz	2chLPCM	H4Kp50_444						
F143	LWR	4096x2160p60.00Hz	2chLPCM	H2_4K_PCM						
F144	LWR	4096x2160p60.00Hz	2chLPCM,8chLPCM,DD...	H2_4K_ALL						
F146	LWR	3840x2160p60.00Hz	2chLPCM	H2_UHD_HDR						
F147	LWR	3840x2160p60.00Hz	2chLPCM	H2_UHD_RB_PCM						
F148	LWR	3840x2160p60.00Hz	2chLPCM,8chLPCM,DD...	H2_UHD_RB_ALL						

EDID Management menu in the LDC

TIPS AND TRICKS: If there is no pre-installed factory EDID in the list that can fit your system, a new EDID can be created via the EDID Creator wizard. See more details about it in the [Creating an EDID - Easy EDID Creator](#) section.

4.10.8. Set the Scalers

Set up the scaler on the HDMI output ports of the receiver for the best user experience. The forced resolution and refresh rate are recommended to fit the supported resolution / refresh rate of the sink device.

DIFFERENCE: The receiver is built with scaler function on both HDMI output ports and the transceiver is built with scaler function on the HDMI in 2 port **from firmware version v2.1.0**. These ports have FRC and CSC functions only in case of previous firmware versions.

DIFFERENCE: The transmitter is built with scaler function on both HDMI input ports **from firmware version v2.4.1**. HDMI in 2 port has FRC and CSC functions only in case of previous firmware versions.

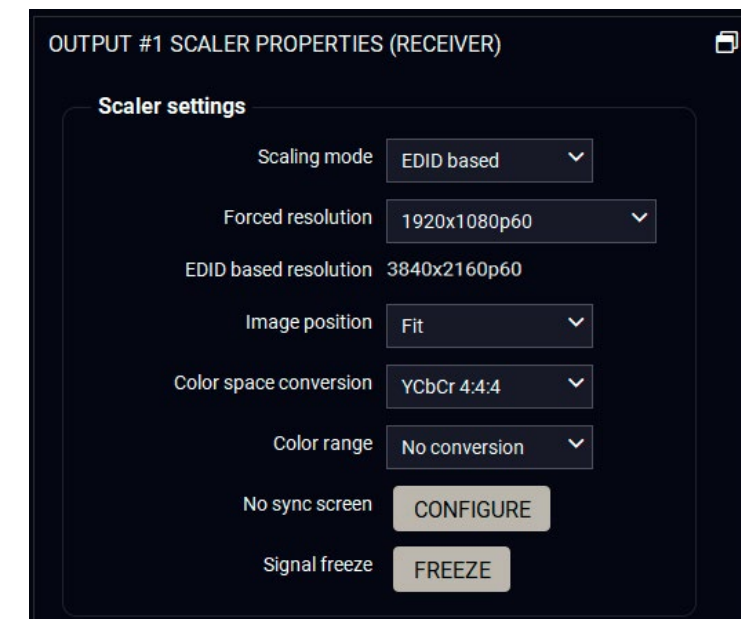
**Scaler - Example**

In our example the sink device is a 4K-ready monitor and we have to display a 4K60 Hz video on it. The signal is transmitted on the HDMI out 1 port of the UBEX receiver.

Navigate to the **Crosspoint menu - Video tab** and select the **Scaler** panel on the receiver side. Set the Scaling Mode setting to **EDID based**, which means the receiver reads out the EDID of the sink device and scales the image to that. In our example it is **3840x2160p60**. Set the Image position to **Fit**, the Color space conversion to **YCbCr 4:4:4**.

INFO: For the **multiviewer installation** you can find a detailed tutorial in the [Multiviewer Designer - Tutorial](#) section.

TIPS AND TRICKS: The stream and the connected display device can be identified by using the [Identify Stream / Identify Display](#) feature. It generates 10 test colors on the display device for 10 seconds.

4.10.9. Set the Audio Streams

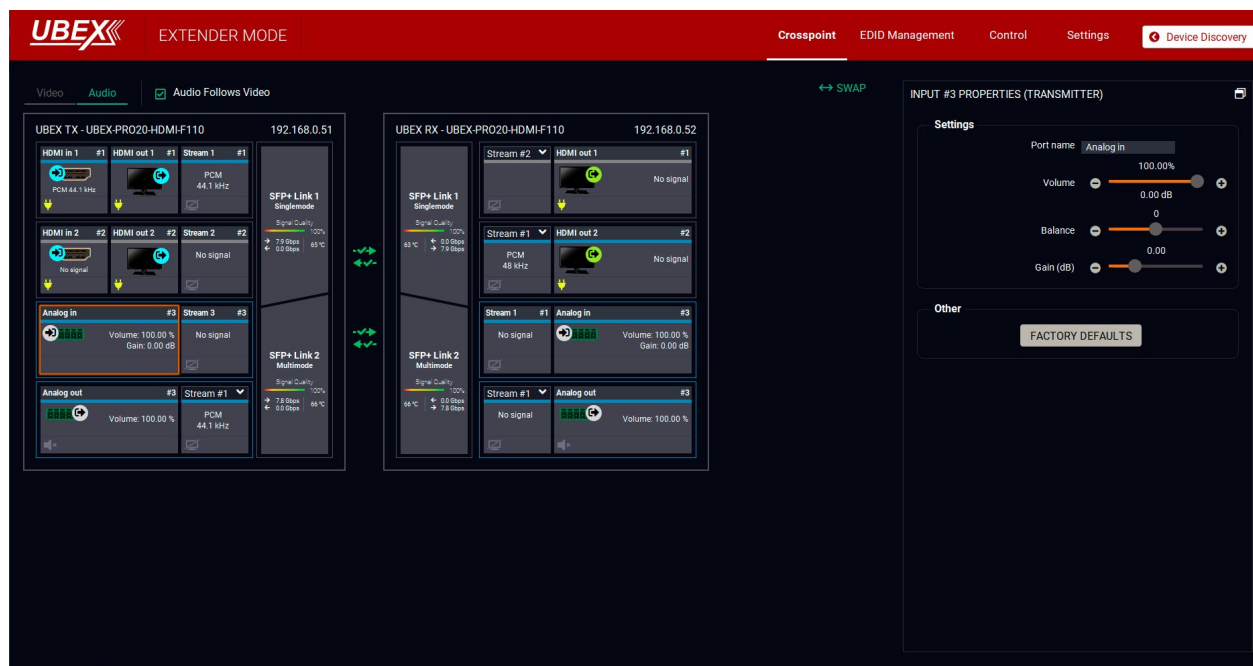

The audio crosspoint menu in the LDC software for an F111 TX-RX pair

Crosspoint Settings

Set up the audio crosspoint settings. Digital and analog audio source streams are also selectable in case of UBEX-PRO20-HDMI-F110, -F111, -F120, F121 and-F130 endpoint devices. All audio streams can be selected to all outputs.

See more details about the audio crosspoint settings in LDC in the [Audio Crosspoint Menu](#) section.

ATTENTION: The audio crosspoint settings always follow the source MUX settings of the video layer and the MUX settings cannot be set in the audio layer.

DIFFERENCE: HBR audio formats are supported from LDC version **v2.5.8b2** and endpoint firmware version **v2.0.0** only. If the embedded audio signal is HBR and an **HBR audio not supported** error message is received during the new crosspoint setting, please update the control software to the latest one. See more information about the updating procedure in the [Install and Update](#) section.

Analog Audio Settings

Set the volume and the balance for the analog audio input and output ports. You can also set the gain for input port. The output can be muted or unmuted.

See more details about these settings in the [Properties Windows - Audio Layer](#) section.

4.10.10. Checkpoints for the Seamless Switching

UBEX series extenders provide seamless switching (clean cut) technology, which is the capability to deliver consistent performance and reliability. The advantage of the technology is that various environments with different video sources and displays will not impact signal loss. *#seamless*

For the best available user experience, please check the following settings being completed to fulfill the requirements of the seamless switching:

- **Emulate the correct EDID:** emulate the right EDID to the HDMI input ports of the transmitter/transceiver. The EDID must be set according to the desired resolution / refresh rate of the stream. For example, emulate the F135 factory EDID track (4096x2160@24Hz 2chLPCM) for a 4096x2160@24Hz resolution.
- **Set the scaler:** set the scaler on the output ports of the receiver or transceiver. The forced resolution and refresh rate are recommended to fit the supported resolution / refresh rate of the sink device. For example, if the preferred resolution of the sink device is 3840x2160@60Hz, apply the following settings in the scaler:
 - Scaling mode: **Forced resolution** or **EDID based**
 - Forced resolution: 3840x2160p60
 - Image position: Fit
 - Timing mode: **Free run**
- **Set the HDCP:** check the HDCP settings both on the input and output ports.
 - Inputs: tick the HDCP enable setting to **enable**.
 - Outputs: if the types of the sink devices are different, set the HDCP mode to **Forced HDCP 2.2 Type 1** (the sink device must support the HDCP 2.2 Type 1).
- **Set the color space:** set the color space (RGB / YCbCr) and the sampling rate (4:4:4 / 4:2:2) to the same value for all sink devices in case of the color space of the signal sources being different.
- **Set the color range:** if the color ranges of the signal source devices are different, this setting helps adjusting between the different types. Lightware recommends the following settings for the color range:
 - If the color range of the signal source devices are the same: set to **No conversion** (default).
 - If the color range of the signal source devices are different: set to **Full range** or **Limited range**, depending on the received source signals.
- **Set the color depth:** if the color depth of the signal source and sink devices are different, this setting helps adjusting between the different types. Lightware recommends the following settings for the color depth:
 - If the color depth of the source and sink devices are the same: set to **Passthrough** (default).
 - If the color depth of the source and sink devices are different: set both side to a fixed value: **8 bpc / 10 bpc / 12 bpc**.

5

UBEX Concept

The following chapter describes the features of the device with a few real-life examples. The topics that are described:

▶ Startup of the System	58
▶ Video Interface	63
▶ Multiviewer Mode	70
▶ Multiviewer Designer - Tutorial	73
▶ Audio Interface	76
▶ Ethernet Control Interface	82
▶ Serial Interface	83
▶ Infrared Interface	83
▶ USB K+M Interface (F120 and F121 Models)	84
▶ USB KVM / USB 2.0 Interface (F130 Model)	85
▶ SFP+ Interface	87
▶ Redundant 10G Link Channels	87
▶ Further Built-in Features	87
▶ Software Control Modes	88

5.1. Video Interface

5.1.1. Transmitter Mode

Port Diagram

The port diagram is valid for the following UBEX endpoint models:

- UBEX-PRO20-HDMI-F100; -F110; -F111; -F120; -F121; -F130
- UBEX-PRO20-HDMI-R100 series

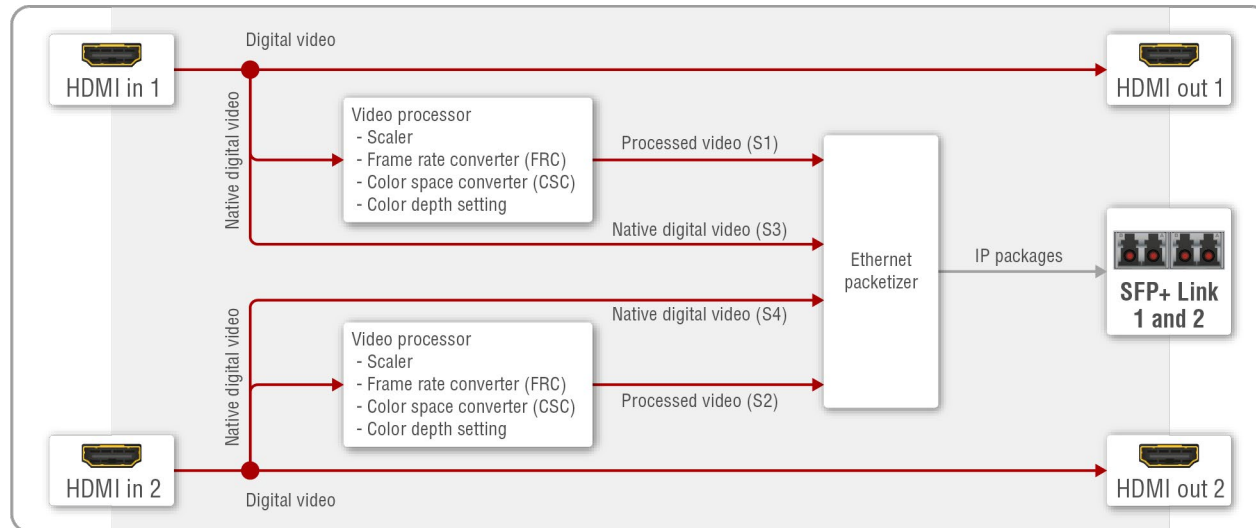

Video port diagram of the F-series and R-series transmitter

HDMI Input Modes

The transmitter can receive HDMI video streams from two HDMI 2.0 input ports. The signals can be up to 4K@60 Hz 4:4:4 in the case of both inputs.

The video streams of the HDMI inputs can be processed in the video processors. The processor of the HDMI in 1 and 2 have **video scaler**, **frame rate converter (FRC)**, **color space converter (CSC)** and **color depth setting** functions.

DIFFERENCE: The transmitter is built with scaler function on both HDMI input ports from firmware version v2.4.1. The HDMI in 2 port has FRC and CSC functions only in case of previous firmware versions.

The scaler settings are available in the LCD menu (see the details in the [TX I1 and TX I2 Ports](#) section) and in the LDC software (see the details in the [Scaler Panel - Input Side \(TX/TRX Modes\)](#) section).

DIFFERENCE: The scaler supports up to **10 bit/channel** color space conversion from firmware package v3.3.0.

The native AV streams (e.g. with 12 bit/channel (deep color) support) can also be transmitted, altogether four streams are switchable on the remote UBEX extender. Please check the 20G bandwidth limitation before the transmission. Find more help for the calculation in the [Bandwidth Requirements of the Resolutions](#) section.

HDMI Output Modes

The HDMI output ports of the transmitter are HDMI loop-back ports and can be used as local HDMI outputs. The HDMI output 1 transmits the signal of the HDMI input 1 port, the HDMI output 2 transmits the signal of the HDMI input 2 port.

Fiber Optical Interface

After the Ethernet packetizing, the two video streams are transmitted to the remote endpoint device via the SFP+ / fiber optical ports.

Summary Tables

	HDMI INPUTS			
	HDMI input 1		HDMI input 2	
	Processed stream	Native stream	Processed stream	Native stream
Accepted signal	up to 4K@60 4:4:4		up to 4K@60 4:4:4	
Scaler	✓	-	✓	-
Frame rate converter (FRC)	✓	-	✓	-
Color space converter (CSC)	✓	-	✓	-
Color depth setting	✓	-	✓	-

	HDMI OUTPUTS	
	HDMI output 1	HDMI output 2
	Output signal	up to 4K@60 4:4:4
Signal source	HDMI input 1	HDMI input 2

2x 4K60 Transmission

The UBEX transmitter is built with 2 pcs of HDMI 2.0 input ports that are capable of receiving 2x 4K60 4:4:4 video streams from the source devices. The two streams together require more than 20 Gbps on the SFP+ links, so this is the bottleneck of the transmission on the fiber optical link. UBEX endpoints offer several settings and AV signal adjustments, that make it possible to transmit 2x 4K60 signal on 20G:

- Color space conversion (CSC):** The built-in color space converter (CSC) helps keeping the resolution of the stream at the expense of the picture quality. If 4:4:4 color sampling generates one unit bandwidth, then in case of 4:2:2 the bandwidth will be 66% of it; in case of 4:2:0, it is halved.
- Color depth setting:** The color depth of the stream can be set on both HDMI input ports. HDMI 2.0 signal in YCbCr color space has 12 bit/channel color depth (over 68 billion possible colors) by default, but it can be converted to 8 bit/channel (16 million possible colors) or 10 bit/channel (1 billion possible colors).

See more details about the bandwidth calculation of the UBEX extenders and more useful tips & tricks in the [Bandwidth Requirements of the Resolutions](#) section.

5.1.2. Receiver Mode

Port Diagram

The port diagram is valid for the following UBEX endpoint models:

- UBEX-PRO20-HDMI-F100; -F110; -F111; -F120; -F121; -F130
- UBEX-PRO20-HDMI-R100 series

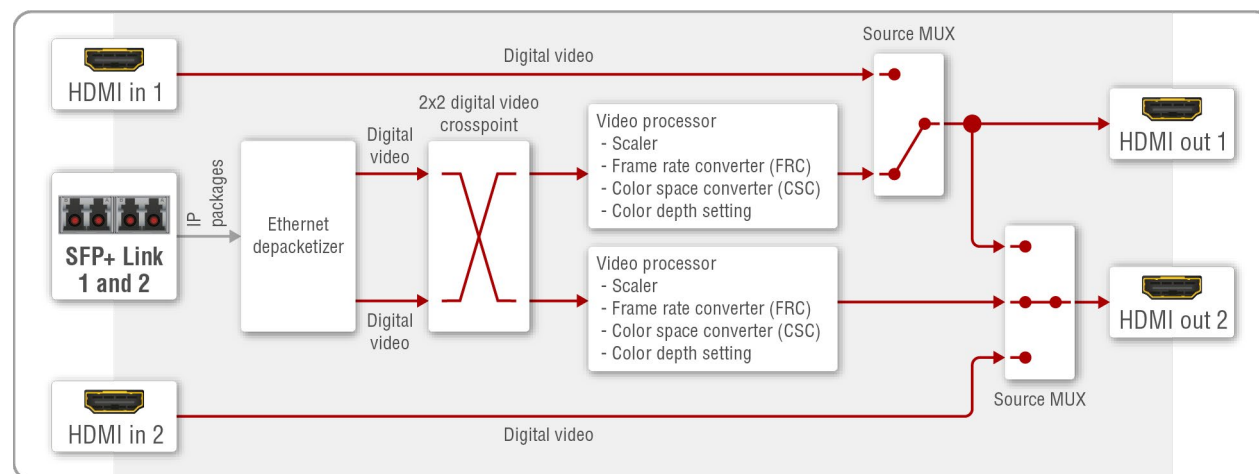

Video port diagram of the F-series and R-series receiver

Fiber Optical Interface

The receiver can receive two HDMI video streams via the SFP+ / fiber optical input ports (SFP+ Link 1 and 2).

HDMI Output Modes

The receiver can transmit HDMI video streams on two HDMI 2.0 output ports. The signal can be up to 4K@60 Hz 4:4:4 in the case of both outputs. The streams received from the remote endpoint device can be routed to any HDMI outputs of receiver, e.g. the stream from the TX - HDMI in 1 can be switched to the RX - HDMI out 1 or 2, or both ones either.

The streams can be processed in the video processors. The processor of the HDMI out 1 and 2 have **video scaler, frame rate converter (FRC), color space converter (CSC)** and **color depth setting** functions.

DIFFERENCE: The receiver is built with scaler function on both HDMI output ports **from firmware version v2.1.0**. The HDMI out 2 port has FRC and CSC functions only in case of previous firmware versions.

The scaler, frame rate converter, and color space converter settings are available in the LCD menu (see the details in the [Stream Output](#) section) and in the LDC software (see the details in the [Scaler Panel - Output Side \(RX/TRX Modes\)](#) section).

Source Multiplexer (MUX)

The source multiplexer (**Source MUX**) makes routing several different source signals to the HDMI output ports available. The type of sources is different for the two outputs.

HDMI out 1

- Able to accept signal up to 4K@60 4:4:4 resolution **via the SFP+ links** from the remote endpoint device;
- Able to accept signal up to 4K@60 4:4:4 resolution **via the local HDMI in 1 port**.

HDMI out 2

- Able to accept signal up to 4K@60 4:4:4 resolution **via the SFP+ links** from the remote endpoint device;
- Able to accept signal up to 4K@60 4:4:4 resolution **via the local HDMI in 2 port**;
- Able to **copy the signal of the HDMI out 1 port** up to 4K@60 4:4:4 resolution. This is the **COPY** function.

HDMI Input Modes

The HDMI input ports of the receiver operate as local HDMI inputs. The stream cannot be affected by any video processing.

Summary Tables

HDMI INPUTS		
	HDMI input 1	HDMI input 2
Accepted signal	up to 4K@60 4:4:4	up to 4K@60 4:4:4
Signal sink	HDMI output 1	HDMI output 2

HDMI OUTPUTS						
	HDMI output 1		HDMI output 2			
	Source MUX			Source MUX		
Signal source	Selected input port of the remote device	Local HDMI input 1	Selected input port of the remote device	Local HDMI input 2	Copy of the HDMI output 1	
Scaler	✓	-	✓	-	-	
Frame rate converter (FRC)	✓	-	✓	-	-	
Color space converter (CSC)	✓	-	✓	-	-	
Color depth setting	✓	-	✓	-	-	

5.1.3. Transceiver Mode

Port Diagram

The port diagram is valid for the following UBEX endpoint models:

- UBEX-PRO20-HDMI-F100; -F110; -F111; -F120; -F121; -F130
- UBEX-PRO20-HDMI-R100 series

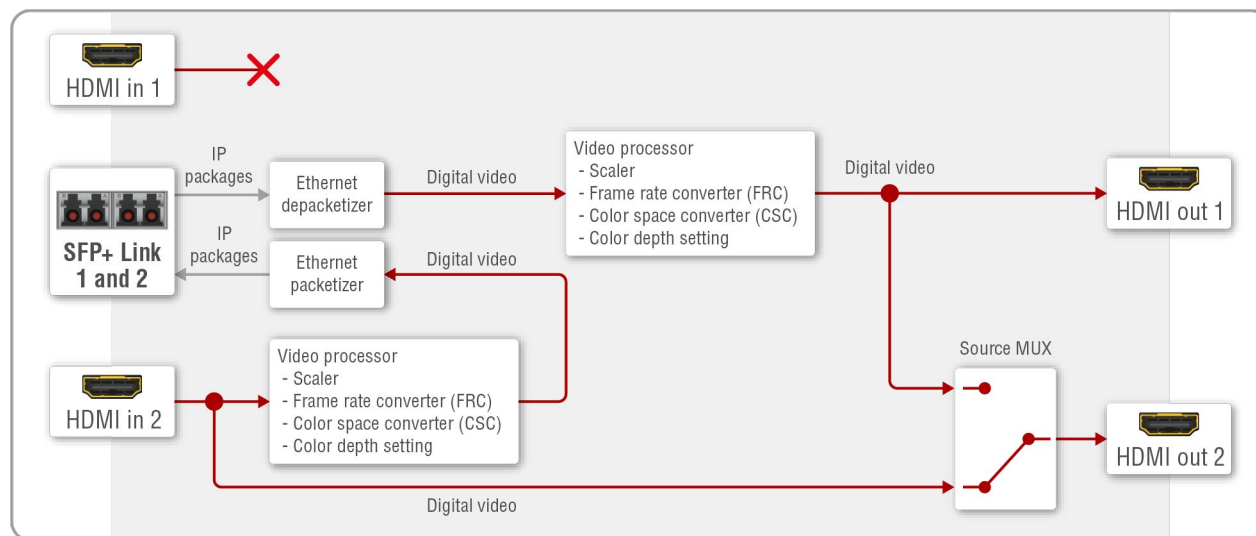

Video port diagram of the F-series and R-series transceiver

Fiber Optical Interface

The transceiver is able to send and receive HDMI video streams together at the same time over the fiber optical links.

HDMI Input Modes

The transceiver can receive one HDMI video stream from the HDMI in 2 input port. The signal can be up to 4K@60 Hz 4:4:4. The video stream can be processed in the video processor. The processor of the HDMI in 2 has **video scaler**, **frame rate converter (FRC)**, **color space converter (CSC)** and **color depth setting** functions. The video processor settings are available in the LCD menu (see the details in the [L \(Local\) TRX I2 Port](#) section) and in the LDC software (see the details in the [Stream Properties Panels \(TX/TRX Modes\)](#) section).

ATTENTION: The HDMI in 1 input port cannot accept video signal.

DIFFERENCE: The transceiver is built with scaler function on HDMI input 2 port from **firmware version v2.1.0**. The port has FRC and CSC functions only in case of previous firmware versions.

HDMI Output Modes

The transceiver can transmit HDMI video streams on two HDMI 2.0 output ports. The signal can be up to 4K@60 Hz 4:4:4 in the case of both outputs.

The HDMI out 1 transmits the HDMI signal coming from the remote UBEX endpoint. The video stream can be processed in the video processor (it contains **scaler**, **frame rate converter (FRC)**, **color space converter (CSC)** and **color depth setting** functions). The video processor settings are available in the LCD menu (see the details in the [L \(Local\) TRX O1 Port](#) section) and in the LDC software (see the details in the [Scaler Panel - Output Side \(RX/TRX Modes\)](#) section).

In default state, the HDMI out 2 transmits the HDMI signal coming from the HDMI in 1 input port so it operates as a local output port. The stream cannot be affected by any video processing.

Source Multiplexer (MUX)

The source multiplexer (**Source MUX**) makes routing several different source signals to the HDMI output 2 port available.

HDMI out 2

- Able to accept signal up to 4K@60 4:4:4 resolution **via the local HDMI in 2** port;
- Able to **copy the signal of the HDMI out 1** port up to 4K@60 4:4:4 resolution. This is the **COPY** function.

Summary Tables

HDMI INPUTS		
	HDMI input 1	HDMI input 2
Accepted signal	⊖	up to 4K@60 4:4:4
Scaler	-	✓
Frame rate converter (FRC)	-	✓
Color space converter (CSC)	-	✓
Color depth setting	-	✓

HDMI OUTPUTS			
	HDMI output 1	HDMI output 2	
Output signal	up to 4K@60 4:4:4	up to 4K@60 4:4:4	
Signal source	Input port of the remote device	Source MUX	
		HDMI input 2	Copy of the HDMI output 1
Scaler	✓	-	-
Frame rate converter (FRC)	✓	-	-
Color space converter (CSC)	✓	-	-
Color depth setting	✓	-	-

2x 4K60 Transmission

The UBEX transceiver is built with a HDMI 2.0 input port and a HDMI 2.0 output port as well that are capable of transmitting 2x 4K60 4:4:4 video streams. The two streams together require more than 20 Gbps on the SFP+ links, so this is the bottleneck of the transmission on the fiber optical link. UBEX endpoints offer several settings and AV signal adjustments, that make it possible to transmit 2x 4K60 signal on 20G:

- **Color space conversion (CSC):** The built-in color space converter (CSC) helps keeping the resolution of the stream at the expense of the picture quality. If 4:4:4 color sampling generates one unit bandwidth, then in case of 4:2:2 the bandwidth will be 66% of it; in case of 4:2:0, it is halved.
- **Color depth setting:** The color depth of the stream can be set on both HDMI input ports. HDMI 2.0 signal in YCbCr color space has 12 bit/channel color depth (over 68 billion possible colors) by default, but it can be converted to 8 bit/channel (16 million possible colors) or 10 bit/channel (1 billion possible colors).



See more details about the bandwidth calculation of the UBEX extenders and more useful tips & tricks in the [Bandwidth Requirements of the Resolutions](#) section.

5.1.4. Bandwidth Limitation

The UBEX endpoints can transmit two video streams at the same time up to 20 Gbps bandwidth. When the bandwidth limit is exceeded, the priority of the streams is the following:



Transmitter Side

The stream of the HDMI in 1 has the higher priority and the stream of the HDMI in 2 will not be transmitted until the bandwidth limit problem is solved (the parameters of the video are still received by the receiver). In that case the stream tile of the disabled stream becomes amber in the LDC software.

Transmitter side	HDMI in 1		HDMI in 2	
	Status	Stream tile (LDC)	Status	Stream tile (LDC)
	Enabled		Disabled	



Receiver Side

The switched stream of the HDMI out 1 has the higher priority and the stream of the HDMI out 2 is going to be disabled (the parameters of the video are still received). In that case the stream tile of the disabled stream becomes amber in the LDC software.

Receiver side	HDMI out 1		HDMI out 2	
	Status	Stream tile (LDC)	Status	Stream tile (LDC)
	Enabled		Disabled	

Transceiver Side

Thanks to the 20G full-duplex SFP+ interface, the transceiver has no bandwidth limitation on the input and output sides either. The device is able to receive and transmit 2x 4K60 Hz 4:4:4 24bit streams on both HDMI ports.

Transceiver side	HDMI in 2		HDMI out 1	
	Status	Stream tile (LDC)	Status	Stream tile (LDC)
	Enabled		Enabled	

INFO: You can find the bandwidth requirements of each resolution in the [Bandwidth Requirements of the Resolutions](#) section.

5.1.5. HDMI Signal Transmission - Example for TX-RX Pair

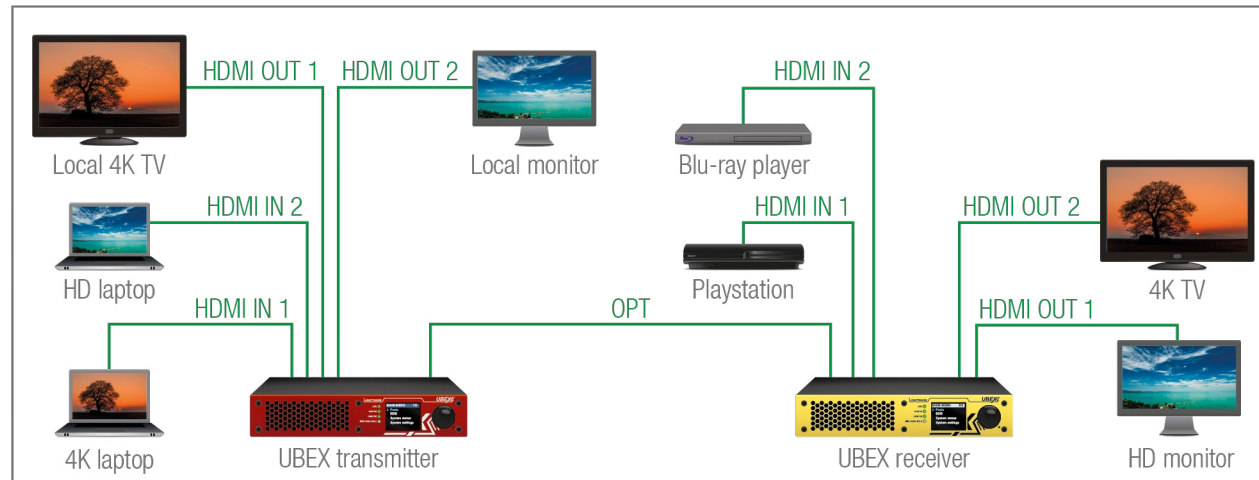

The Concept

Two source devices are connected to the UBEX transmitter: a 4K laptop built with a 4K graphic card (output signal: 4K60) and an HD laptop (output signal: 1080p60). Two sink devices are also connected to the local output ports of the transmitter: a local 4K TV and a local monitor.

The two streams from the 4K laptop and the HD laptop are transmitted to the UBEX receiver via the fiber optical line.

Two local source devices are connected to the UBEX receiver: a Playstation and a Blu-ray player. The signals can only be transmitted over the output ports of the receiver.

The receiver is able to copy the signal of the HDMI out 1 to the HDMI out 2. If any signal modification (scaling, color space changing, etc) has been applied, the modified stream will be copied.

The receiver transmits the selected streams toward two sink devices: a 4K TV and a full HD (1080p) monitor.

Available Crosspoint Settings

			Destinations			
			Transmitter		Receiver	
			HDMI out 1 Local 4K TV	HDMI out 2 Local monitor	HDMI out 1 HD monitor	HDMI out 2 4K TV
Sources	Transmitter	HDMI in 1 4K laptop	✓	-	✓	✓
		HDMI in 2 HD laptop	-	✓	✓	✓
	Receiver	HDMI in 1 Playstation	-	-	✓	-
		HDMI in 2 Blu-ray player	-	-	-	✓
		Copy of the HDMI out 1	-	-	-	✓

The local output ports of the transmitter are fixed: the HDMI out 1 transmits the HDMI in 1 stream, the HDMI out 2 transmits the HDMI in 2 stream.

The streams coming from the transmitter can be switched between the two output ports of the receiver. For example, the HDMI in 1 stream can be switched to the HDMI out 1 and out 2 as well.

Scaling Options

If the stream of the 4K laptop is switched to the HD monitor on the HDMI out 1, it cannot display the high-resolution video. The solution is that the stream transmitted on the HDMI out 1 can be scaled for the sink device, which supports lower resolutions only. For example, the 4K60 video is scaled to 1080p60 and the stream can be displayed on the HD monitor as well.

The scaler is available on the receiver and transmitter side as well. The stream of the HDMI in 1 can be re-scaled and the transmitter transmits the optimized stream toward the receiver.

Lightware Device Controller (LDC)

The crosspoint settings are available in the LCD menu of the device (see the details in the [RX O1 and RX O2 Ports](#) section) and in the LDC software (see the details in the [Video Crosspoint Menu](#) section).

5.1.6. HDMI Signal Transmission - Example for TRX-TRX Pair

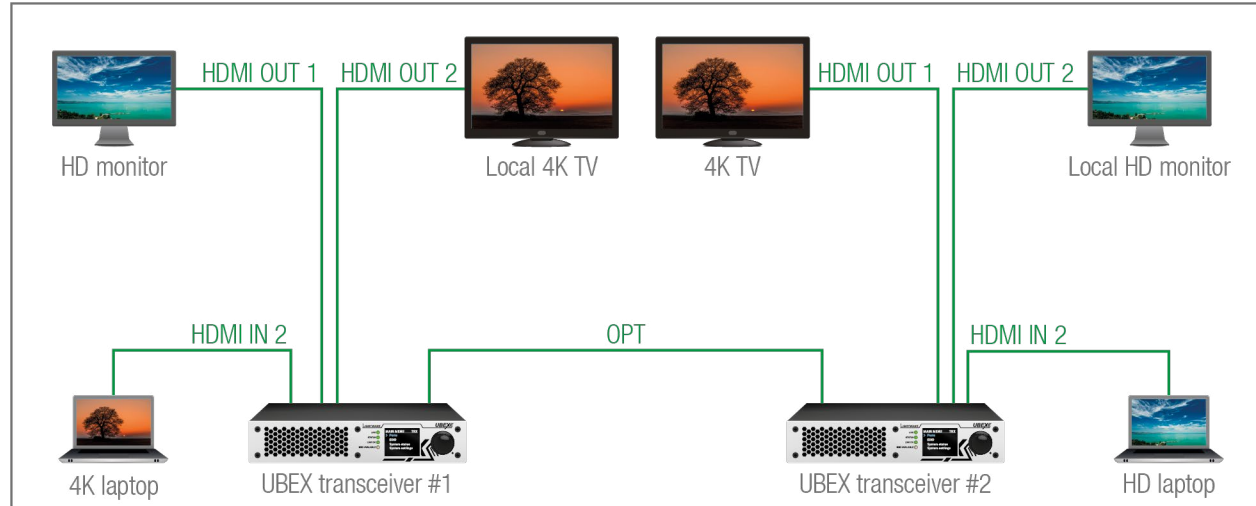

The Concept

Two source devices are installed in the system: a 4K laptop connected the TRX #1, and a HD laptop connected to the TRX #2. The stream of the 4K laptop is sent to the HDMI out 1 port of the TRX #2 (4K TV) and also transmitted to the local output port of the TRX #1 (Local 4K TV). The stream of the HD laptop is sent to the HDMI out 1 port of the TRX #1 (HD monitor) and also transmitted to the local output port of the TRX #2 (Local HD monitor).

Available HDMI Signal Routing

			Destinations			
			Transceiver #1		Transceiver #2	
			HDMI out 1 HD monitor	HDMI out 2 Local 4K TV	HDMI out 1 4K TV	HDMI out 2 Local HD monitor
Sources	TRX #1	HDMI in 2 4K laptop	-	✓	✓	-
		Copy of HDMI out 1	-	✓	-	-
	TRX #2	HDMI in 2 HD laptop	✓	-	-	✓
		Copy of HDMI out 1	-	-	-	✓

Explanation

The input of the Transceiver #1 is displayed on the local HDMI output (HDMI out 2) and the output of the Transceiver #2 (HDMI out 1), and the input of the Transceiver #2 is displayed on the local HDMI output (HDMI out 2) and the output of the Transceiver #1 (HDMI out 1).

The transceivers are able to copy the signal of the HDMI out 1 to the HDMI out 2. If any signal modification (scaling, color space changing, etc) has been applied, the modified stream will be copied.

5.1.7. Timing Modes

Technical Background

UBEX receivers and transceivers provide two different timing modes on the HDMI outputs:

- **Free run:** the receiver generates nominal clock frequency, which is not bonded to the source. It means TBC (time base correction) is applied in the stream, which may cause frame repetition/drop between minimum 1 and maximum 2 frames value. **The seamless stream switching is available in this mode only.**
- **Source locked:** time stamps are transmitted with the stream from the source, and the receiver can generate accurate clock frequency; in this way the latency within one frame (up to 16 lines) can be guaranteed. This mode is ideal for the video walls where the extra low latency is the most important requirement.

ATTENTION: Seamless switching is available only if the timing mode is set to **free run**.

The setting is available in the LDC software (see the details in the [Local HDMI Input Ports \(RX Mode\)](#) section) and by LW3 protocol commands (see the details in the [Timing Mode Setting](#) section).

Application of Timing Mode Settings - Example

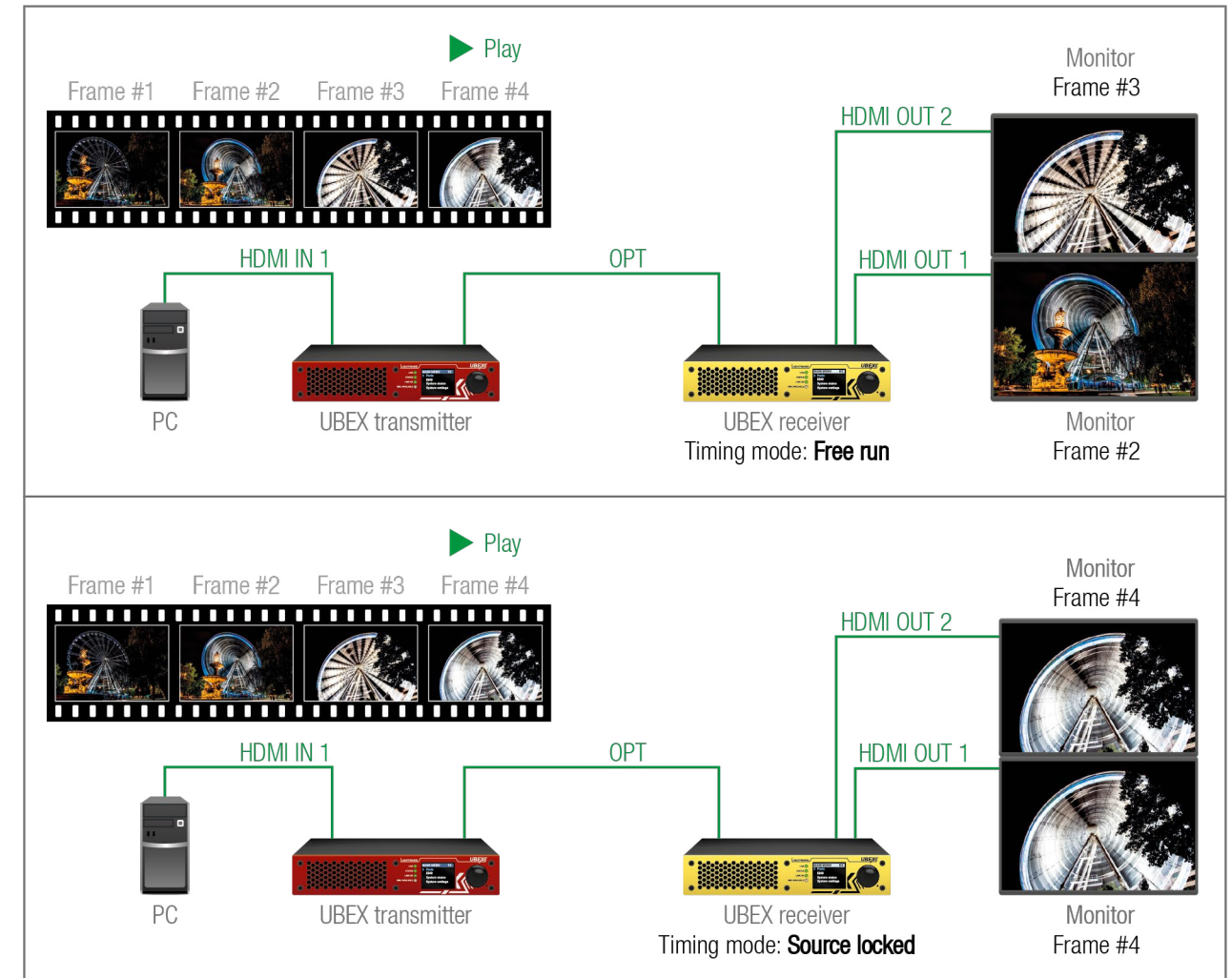

The Concept

The two PCs play the same content and the playing time is in the same moment (Frame #4) in both cases.

The HDMI output ports of the upper UBEX receiver are set to **free run**. The differences between the actual content of the connected monitors might be noticeable.

The HDMI output ports of the lower UBEX receiver are set to **source locked** so the video stream is generated in the receiver, which does not engage any delay compared to the original stream.

5.1.8. The Difference between the Image Positions of the Scaler

The following section helps to understand how the image position settings of the scaler works. Three different image positions are available: **stretch**, **fit** and **center**.

DIFFERENCE: The receiver is built with scaler function on both HDMI output ports and the transceiver is built with scaler function on the HDMI in 2 port **from firmware version v2.1.0**. The HDMI out 2 port has FRC and CSC functions only in case of previous firmware versions.

DIFFERENCE: The transmitter is built with scaler function on both HDMI input ports **from firmware version v2.4.1**. The HDMI in 2 port has FRC and CSC functions only in case of previous firmware versions.

The aspect ratio of the original stream and the sink device are different in the following examples.

Stretch

The aspect ratio of the stream is distorted because it is adjusted to the aspect ratio of the sink.



Fit

The picture is adjusted to the resolution of the sink and the aspect ratio of the stream is kept, thus the whole picture will be displayed without cropping. The scaler fills the extra image part with black pixels.



Center

The scaler crops the center part of the stream with the resolution of the sink.



5.2. Multiviewer Mode

DIFFERENCE: The multiviewer operation mode for the endpoint devices is available only from the firmware package v3.2.0. `#multiviewer #rxmv`

ATTENTION: The multiviewer mode has no Lightware Device Controller (LDC) software support in Extender application mode. The multiviewer feature can be configured and managed with full support by **LW3 protocol commands**.

UBEX multiviewer is a special operation mode of the endpoint device where video signals from different sources can be displayed on one single sink device ordered by various layouts.

5.2.1. Activation of the Multiviewer Mode

Multiviewer is an operation mode of the endpoint device like transmitter, receiver or transceiver. It can be turn on by two methods:

- Front panel LCD menu;
- LW3 protocol commands.

Front Panel LCD Menu Operation

- Step 1.** Navigate to the **System settings / Operation mode** submenu using the jog dial control knob.
- Step 2.** Select the **Switch mode...** option.
- Step 3.** Select the **Multiviewer** mode.
- Step 4.** Confirm the selection, press the **Yes**.
- Step 5.** Wait until the device resets and reboots. After booting up, the unit works in the selected mode.

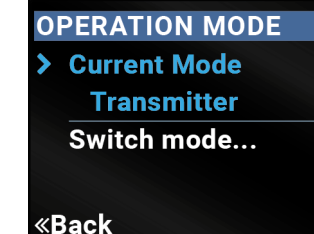

ATTENTION: This operation requires to **reboot** the endpoint device.

LW3 Protocol Command

- Step 1.** Connect to the MMU using a terminal application (e.g. Putty) or use the built-in Terminal of the LDC software / Built-in web. See more details in the [Instructions for the Terminal Application Usage](#) and the [Terminal Window](#) section.
- Step 2.** Type the following command to change the operation mode to multiviewer:

▶ `CALL /SYS/MB.setOperationModeAndReset=<operation_mode>`

Example:

▶ `CALL /SYS/MB.setOperationModeAndReset=Multiviewer`

ATTENTION: This operation requires to **reboot** the endpoint device.

5.2.2. Definitions

The multiviewer mode brings several new definitions in the user manual. This section is dedicated to clear up all of them.

- **Multiviewer:** the multiview video content means several tiles placed on a canvas where one tile contains one video stream.
- **Canvas:** the surface where the tiles are located. Its resolution is usually the same as the resolution of the sink device, but it can be different. In case of UBEX multiviewer, the canvas with the tile(s) cannot be scaled or manipulated on the multiviewer side, but streams can be processed several different way on the transmitter/transceiver side.
- **Tile:** the tile contains the video content on the canvas. Up to four tiles can be placed on the canvas in the UBEX multiviewer system. The resolution of the tile must be smaller than the resolution of the canvas. One tile contains one video stream. In case of UBEX multiviewer, the resolution of the stream and the size of the tile must be the same.

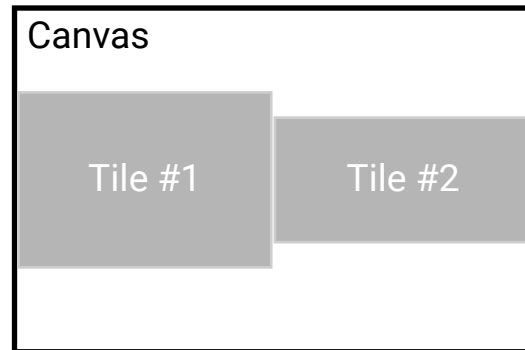

Multiview Layouts

- **Picture-by-picture multiview:** layout of two equally wide tiles which are placed side-by-side, the tiles can overlap each other and the video format of the tiles can be different. The empty spaces of the canvas will be filled by black pixels.
- **Picture-in-picture multiview:** layout of two or more tiles which overlap each other. The size of the foreground tile is always smaller than the background tile's one. There is no pillarbox and letterbox around the foreground tile, its Active and Content have the same resolution. The empty spaces of the canvas will be filled by black pixels.

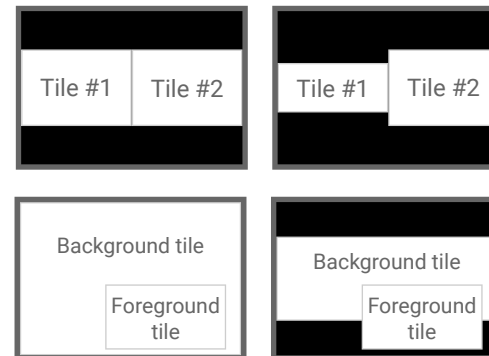

5.2.3. Description

UBEX multiviewer is a special operation mode of the endpoint device where video signals from different sources can be displayed on one single sink device ordered by various layouts. The key features of the UBEX multiviewer are the following:

- Handles **up to 2 different sources** so usually **up to 2 tiles** are placed the canvas;
- The Active and the Content of the tiles have the same sizes, which means **neither Pillarbox nor Letterbox are defined** in the UBEX multiviewer system;
- **Picture-by-picture** and **picture-in-picture** layouts are supported;
- Tiles can **overlap** each other;
- Tiles must be placed within the canvas area, **extending beyond the canvas is not supported**;
- Multiviewer supports **RGB color space only**;
- In case of HDCP authentication problem of a tile, the whole canvas area will be filled with black pixels;
- **Audio streams** can be switched **independently** in the Audio layer.

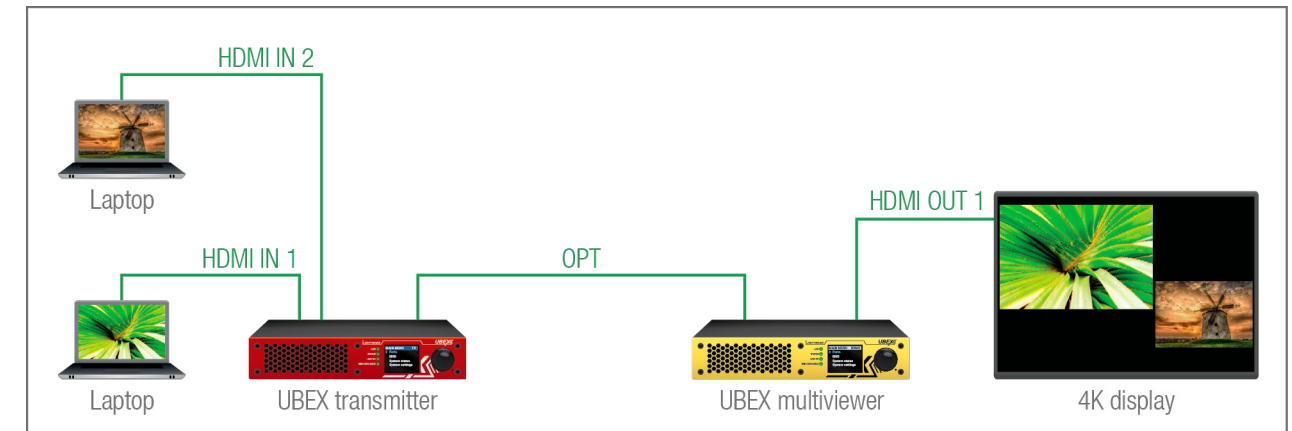

Installation example for the multiviewer feature

5.2.4. Port Diagram

The port diagram is valid for the following UBEX endpoint models:

- UBEX-PRO20-HDMI-F100; -F110; -F111; -F120; -F121; -F130
- UBEX-PRO20-HDMI-R100 series

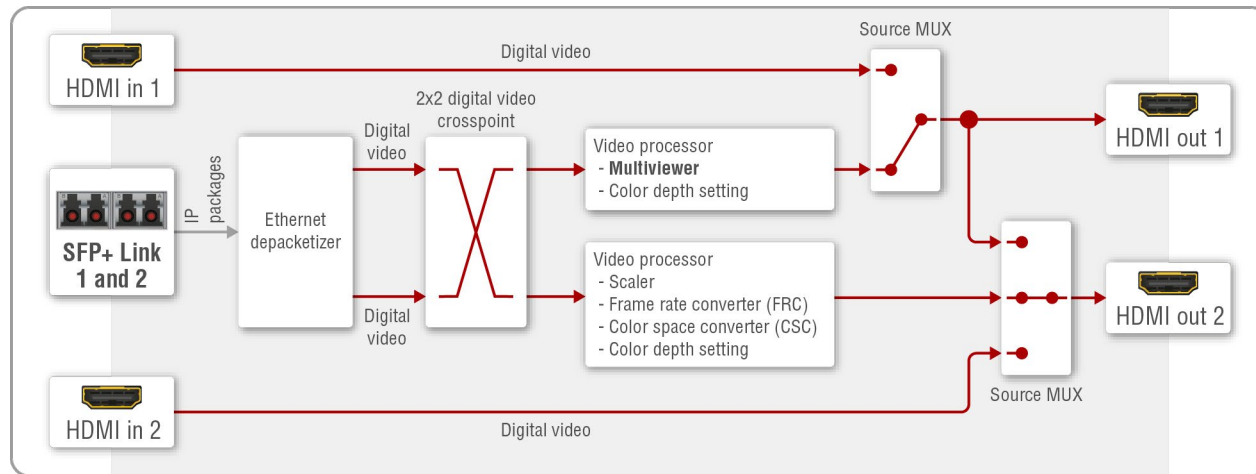

Video port diagram of the F-series and R-series multiviewer

Fiber Optical Interface

The multiviewer can receive **up to five** HDMI video streams via the fiber optical input ports **up to 20 Gbps bandwidth**.

HDMI Output Modes

The multiviewer can transmit HDMI video streams on two HDMI 2.0 output ports. The signal can be up to 4K@60 Hz 4:4:4 in the case of both outputs.

ATTENTION: Multiviewer supports **RGB color space only**.

HDMI Out 1

Up to four video streams can be received from the remote endpoint devices, which can be routed to the HDMI output 1 port and organized into various layouts.

The canvas (including all tile streams) can be processed in the video processor that has **color depth setting** function.

The multiviewer functions and the color depth setting are available by LW3 protocol commands only, see more details in the [Multiviewer Configuration](#) section.

HDMI Out 2

The stream received from the remote endpoint device can be routed to the HDMI output 2.

The streams can be processed in the video processors. The processor of the HDMI 2 has **video scaler**, **frame rate converter (FRC)**, **color space converter (CSC)** and **color depth setting** functions.

Source Multiplexer (MUX)

The source multiplexer (**Source MUX**) makes routing several different source signals to the HDMI output ports available. The type of sources is different for the two outputs.

HDMI out 1

- Able to accept up to four signals **via the SFP+ links** from up to four remote endpoint device;
- Able to accept signal up to 4K@60 4:4:4 resolution **via the local HDMI in 1** port.

HDMI out 2

- Able to accept signal up to 4K@60 4:4:4 resolution **via the SFP+ links** from the remote endpoint device;
- Able to accept signal up to 4K@60 4:4:4 resolution **via the local HDMI in 2** port;
- Able to **copy the signal of the HDMI out 1** port up to 4K@60 4:4:4 resolution. This is the **COPY** function.

HDMI Input Modes

The HDMI input ports of the multiviewer operate as local HDMI inputs. The stream cannot be affected by any video processing.

Summary Tables

HDMI INPUTS		
	HDMI input 1	HDMI input 2
Accepted signal	up to 4K@60 4:4:4	up to 4K@60 4:4:4
Signal sink	HDMI output 1	HDMI output 2

HDMI OUTPUTS					
	HDMI output 1		HDMI output 2		
Output signal	up to 4K@60 4:4:4		up to 4K@60 4:4:4		
Signal source	Source MUX		Source MUX		
	Multiviewer input streams (up to four sources)	Local HDMI input 1	Selected input port of the remote device	Local HDMI input 2	Copy of the HDMI output 1
Scaler	-	-	✓	-	-
Frame rate converter (FRC)	-	-	✓	-	-
Color space converter (CSC)	-	-	✓	-	-
Color depth setting	✓	-	✓	-	-

5.2.5. Options and Features

The following options and features are available in the UBEX multiviewer system via LW3 protocol commands.

INFO: At recent stage of development the multiviewer features and settings are available by LW3 protocol commands only.

Canvas size / resolution



The resolution of the canvas is equal to the resolution of the sink device.

Available:

- via LW3 protocol command - [Setting the Resolution of the Canvas](#)

Tile position



The position of the tile inside the canvas can be set. The top left corner of the tile is the starter pixel, the required parameters are the horizontal and vertical pixels.

Tiles must be placed within the canvas area, extending beyond the canvas is not supported.

Available:

- via LW3 protocol command - [Tile Position Setting](#)

Enable/disable the tile

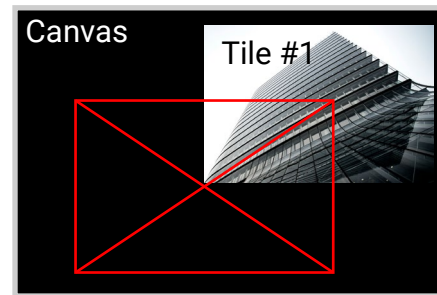

The desired tile can be muted and switched on again anytime.

Available:

- via LW3 protocol command - [Enabling/Disabling the Tile](#)

Tile size / resolution



The tile size and the resolution of the input stream must be the same.

Tiles must be placed within the canvas area, extending beyond the canvas is not supported.

Available:

- via LW3 protocol command - [Tile Size Setting](#)

Layer order



The setting is for re-prioritization of the tile layouts which can use in case of the tiles overlap each other. The priority of the tiles determines which is in front.

Available:

- via LW3 protocol command - [Layer Order Setting](#)

Tile opacity

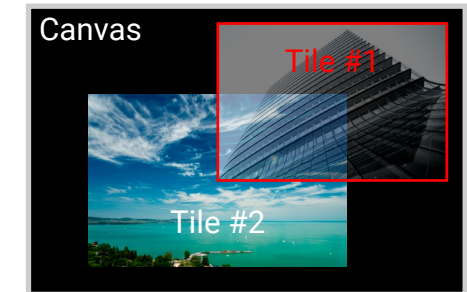

The setting adjusts the opacity of the selected tile. The opacity is in percent, 100% means the stream is not transparent, 0% means the stream is not visible.

Available:

- via LW3 protocol command - [Tile Opacity Setting](#)

5.2.6. Multistream Feature of the Transmitter

DIFFERENCE: The multistream feature for the transmitter is available from **firmware version v3.3.0**.

The transmitter is able to transmit the **processed** and the **native** version of the stream at the same time. There are dedicated stream lines built into the transmitter and the user can decide which one or both together are wanted to be transmitted toward to the sink devices. The feature gives opportunity to decide according to the needs of the user.

The feature brings more audio and video ports to the endpoints in all operation modes, please check the [Input/Output Port Numbering](#) section before set the crosspoint.

ATTENTION: Always check the bandwidth limitation of the endpoints. See the formula to the bandwidth calculation in the [Bandwidth Requirements of the Resolutions](#) section.

5.3. Multiviewer Designer - Tutorial

The following tutorial helps the installation and configuration of the UBEX multiviewer system including useful tips and tricks to optimize your network traffic as well.

5.3.1. Installation

Set the operation mode of the endpoint devices. The source side shall be transmitter (TX), the sink side shall be the multiviewer (RXMV). There are two methods to set the operation mode:

- via **Front panel LCD operation** - see the details in the [Operation Mode](#) section;
- via **LW3 protocol command** - see the details in the [Set the Operation Mode](#) section.

The **HDMI out 1** port can be used for multiviewer purpose.

See more detailed installation steps and notices in the [F-series Endpoints - Multiviewer Operation Mode](#) and the [R-series Endpoints - Multiviewer Operation Mode](#) sections.

5.3.2. Configuration

INFO: At recent stage of development the multiviewer features and settings are available by LW3 protocol commands only. See all related commands in the [Multiviewer Configuration](#) section.

The following steps are required to configure the multiviewer system. The steps are listed in logical order but they can be interchangeable.

Set the Resolution of the Canvas

The resolution of the canvas is equal to the resolution of the sink device. For example if the sink where the multiviewer is designed is a 4K UHD monitor, set the canvas size to 3840x2160p60. The canvas size setting of the multiviewer is available via:

- **LW3 protocol command** - see the details in the [Setting the Resolution of the Canvas](#) section.

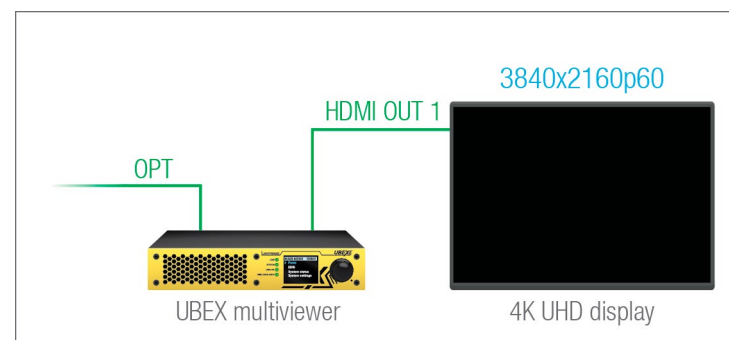

Set the Resolution of the Source Streams

Two source streams can be received on the transmitter side which can be processed by the UBEX transmitter before they are transmitted to the multiviewer.

This example presents a picture-in-picture multiviewer layout where there is a background and a foreground stream on the multiviewer sink. Two source devices are connected to the transmitter: a 4K UHD capable laptop and a FHD laptop with 1920x1080p60 resolution.

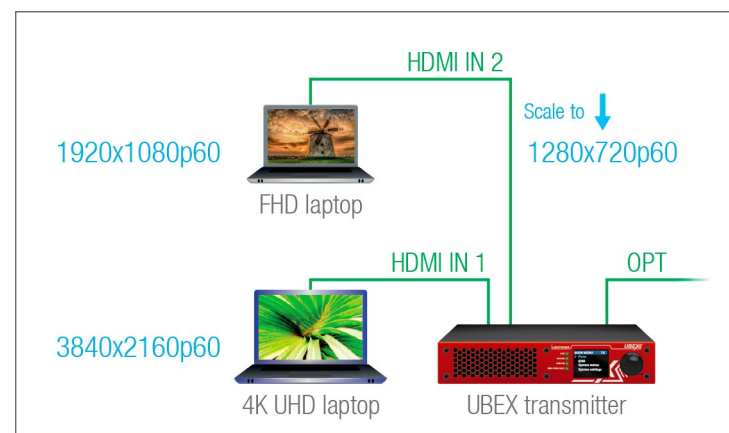

In our example the size of the foreground tile will be 1280x720 so the stream 2 on the HDMI in 2 port needs to be scaled from 1920x1080p60 to 1280x720p60. The scaler setting of the transmitter is available via:

- **Front panel LCD operation** - see the details in the [TX I1 and TX I2 Ports](#) section;
- **Lightware Device Controller (LDC) software** - see the details in the [Scaler Panel - Input Side \(TX/TRX Modes\)](#) section;
- **LW3 protocol command** - see the details in the [Resolution Mode Setting](#) and the [Tile Resolution Setting](#) sections.

Optimize the Source Streams

The 20G connection between the two endpoints is enough to build a basic picture-in-picture multiview like in our example, a 4K UHD background and a 720p foreground streams. If the network traffic needs to be optimized, UBEX transmitter provides adjusting the color depth of the streams, which can result in reduced signal bandwidths

Here are the detailed information of the original streams:

Stream	Resolution and refresh rate	Color sampling	Color depth	Required bandwidth
Stream 1 on HDMI in 1	3840x2160@60Hz	4:4:4	24 bit (8 bit/ch)	12.9 Gbps
Stream 2 on HDMI in 2	1280x720@60Hz	4:4:4	36 bit (12 bit/ch)	2.15 Gbps

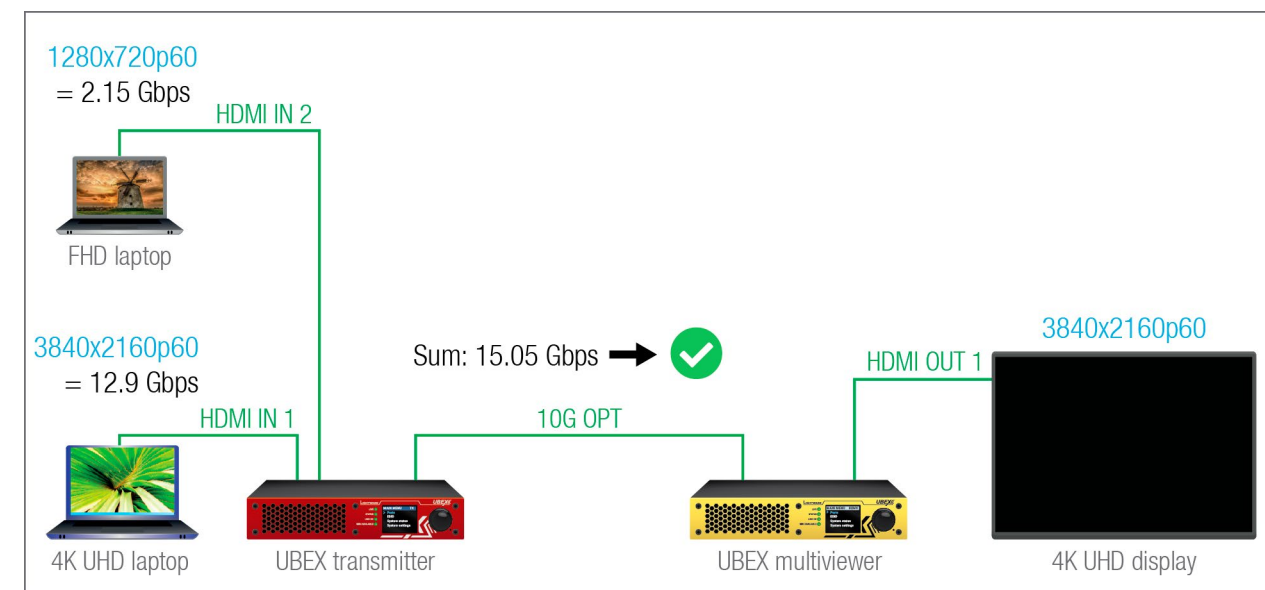

Bandwidth Error

If the bandwidth of the source streams is out of the range, the tiles will not be displayed on the canvas and the tile status will be "BandwidthError".

The actual status of the tile of the multiviewer is available via:

- **LW3 protocol command** - see the details in the [Querying the Status of the Tile](#) section.

Optimization and Signal Processing

The transmitter has a built-in color depth converter on both input ports. The following signal processing can be applied on the streams to reduce the required bandwidth:

Stream	Resolution and refresh rate	Color sampling	Color depth	Required bandwidth
Stream 1 on HDMI in 1	3840x2160@60Hz	4:4:4	24 bit (8 bit/ch)	12.9 Gbps
Stream 2 on HDMI in 2	1280x720@60Hz	4:4:4	24 bit (8 bit/ch)	1.43 Gbps

The color depth converter of the transmitter is available via:

- **Front panel LCD operation** - see the details in the [TX I1 and TX I2 Ports](#) section;
- **Lightware Device Controller (LDC) software** - see the details in the [Scaler Panel - Input Side \(TX/TRX Modes\)](#) section;
- **LW3 protocol command** - see the details in the [Color Depth Setting](#) section.

Crosspoint Settings

ATTENTION: At recent stage of the development the multiviewer mode and the multistream feature has no Lightware Device Controller (LDC) software support. The multiviewer feature can be configured and managed with full support by **LW3 protocol commands**. It affects that not all crosspoint possibility can be accessed in LDC.

Querying the crosspoint settings possibilities is available via:

- **LW3 protocol command** - see the details in the [Query the Video Crosspoint Setting](#) section.

The crosspoint setting of the transmitter is available via:

- **LW3 protocol command** - see the details in the [Switching the Stream](#) section.

Set the Tile Sizes

Two tiles can be placed on the canvas for the two source streams.

ATTENTION: The size of the tiles must be the same as the resolution of the streams.

If the resolution of the tile and the source stream is not equal, the tile will not be displayed on the canvas and the tile status will be "InvalidSize".

The tile size setting of the multiviewer is available via:

- **LW3 protocol command** - see the details in the [Tile Size Setting](#) section.

The actual status of the tile in the multiviewer is available via:

- **LW3 protocol command** - see the details in the [Querying the Status of the Tile](#) section.

Why the foreground tile does not appear on the canvas? It appears but located **behind** the background tile. The layout of the tiles needs to be rearranged - the next section describes the method.

Reorder the Layout of the Tiles

The prioritization of the tiles determines which is in front. The default priority is the #1 is first tile (T1 - this is the background tile in our example), the #2 is the second tile (T2 - this is the foreground tile in our example). The lower number means the front location of the tile so the T2 needs to be set as the #1.

The layout order setting of the multiviewer is available via:

- **LW3 protocol command** - see the details in the [Layer Order Setting](#) section.

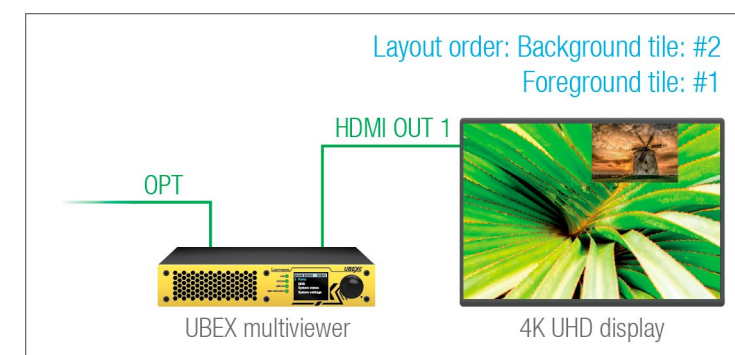
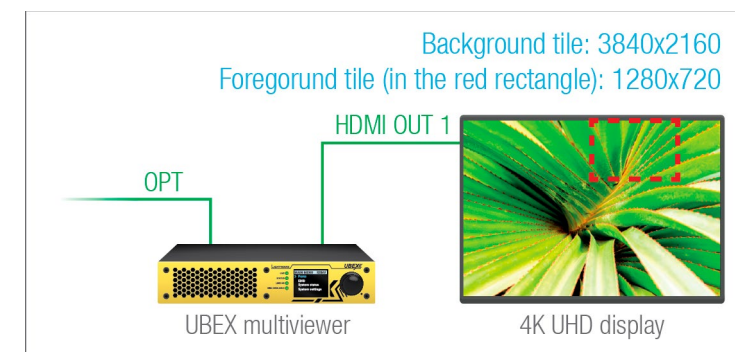

Set the Position of the Tile

The default positions of the tiles is 0,0 and 1920,0. In our example the foreground tile should be located around the lower right area of the canvas so the position of the second tile needs to be changed to 1920,1080.

The formula of the tile position is: horizontal_pixel,vertical_pixel

The tile position setting of the multiviewer is available via:

- **LW3 protocol command** - see the details in the [Tile Position Setting](#) section.

ATTENTION: Tiles must be placed within the canvas area, extending beyond the canvas is not supported. If a part of the tile is located beyond the canvas area, the tile will not be displayed and the tile status will be "InvalidPosition".

The actual status of the tile of the multiviewer is available via:

- **LW3 protocol command** - see the details in the [Querying the Status of the Tile](#) section.

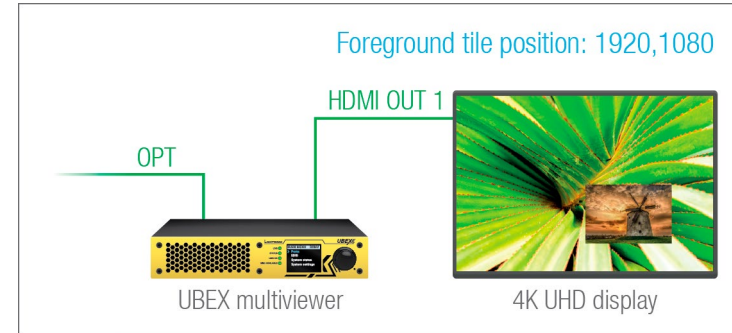

Optionally - Set the Opacity of the Tile

The setting adjusts the opacity of the selected tile. The opacity value is in percent, 100% means the stream is not transparent, 0% means it is not visible.

The tile opacity setting of the multiviewer is available via:

- **LW3 protocol command** - see the details in the [Tile Opacity Setting](#) section.

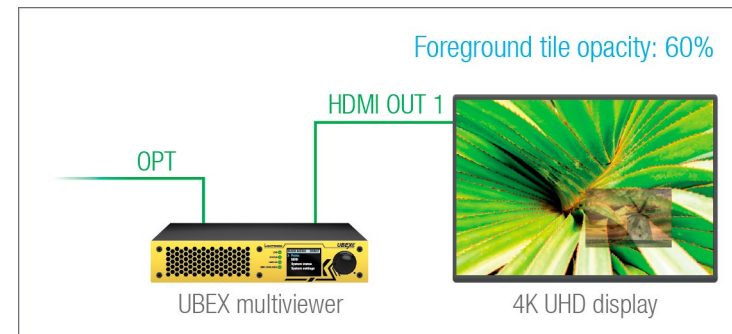

Optionally - Enable or Disable the Tile

Any tile can be disabled or enabled again in the multiviewer system. In our example the background tile is disabled and the foreground tile is enabled.

The enable/disable setting of the tiles of the multiviewer is available via:

- **LW3 protocol command** - see the details in the [Enabling/Disabling the Tile](#) section.

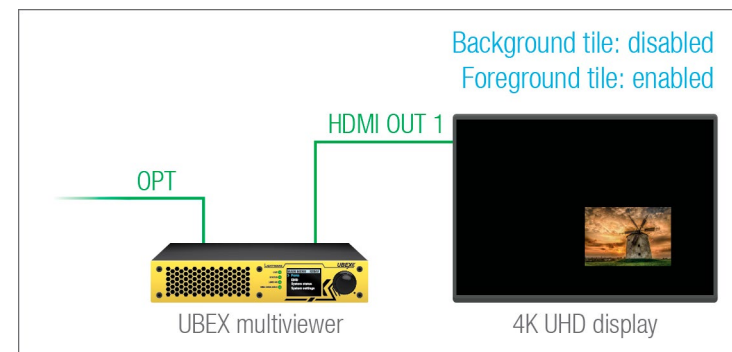

5.4. Audio Interface

5.4.1. Transmitter Mode - F100 / R100 Models

Port Diagram

The port diagram is valid for the following UBEX endpoint model:

- UBEX-PRO20-HDMI-F100
- UBEX-PRO20-HDMI-R100 series

Description

The transmitter receives HDMI audio signals via the two HDMI input ports. The audio streams are transmitted toward the remote endpoint device over the SFP+ links.

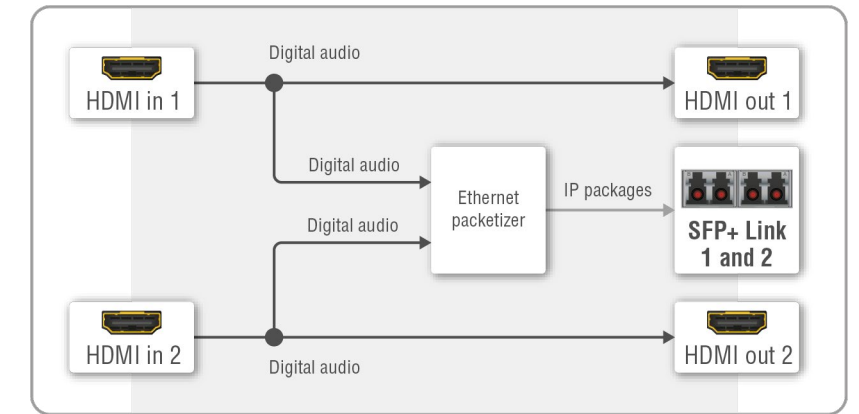

The two source streams can be selected to any output port on the remote endpoint side. The crosspoint setting is available in the transmitter as well.

The HDMI output ports of the transmitter are HDMI loop-back ports and can be used as local HDMI outputs.

5.4.2. Receiver Mode - F100 / R100 Models

Port Diagram

The port diagram is valid for the following UBEX endpoint model:

- UBEX-PRO20-HDMI-F100
- UBEX-PRO20-HDMI-R100 series

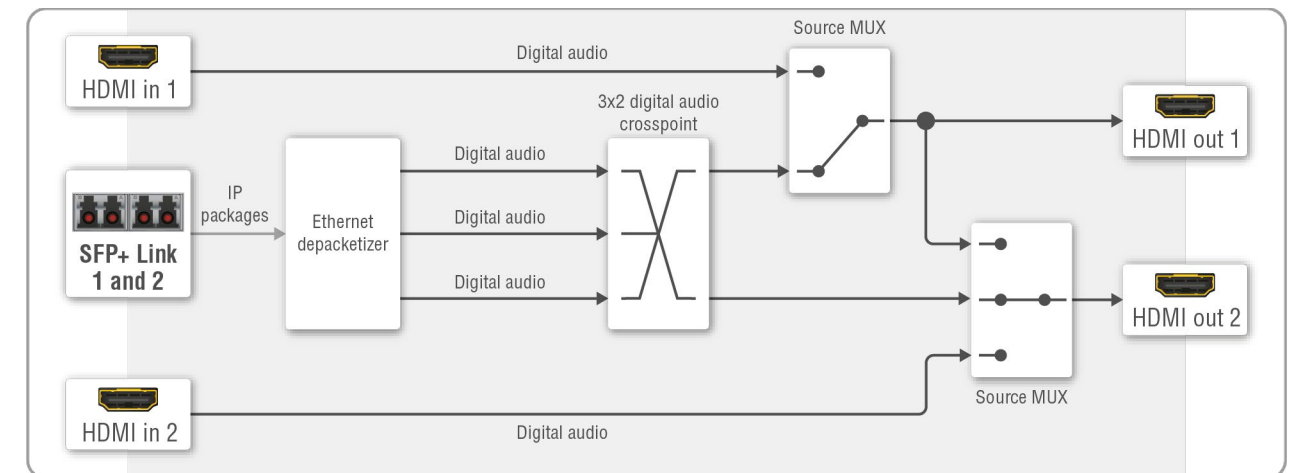

Audio port diagram of the F100/R100 receiver in connection with an F110/F120 endpoint

Description

The receiver can receive two HDMI audio streams via the SFP+ links. The streams can be selected to any HDMI output ports, the crosspoint setting is available in the receiver as well.

Source Multiplexer (MUX)

INFO: The source MUX function can be set on the video side only in the Lightware Device Controller (LDC) software, and using LW3 protocol commands as well.

The source multiplexer (**Source MUX**) makes routing several different source signals to the HDMI output ports available. The type of sources is different by the two outputs.

HDMI out 1

- Able to accept audio signal **via the SFP+ links** from the remote endpoint device;
- Able to accept audio signal **via the local HDMI in 1 port**.

HDMI out 2

- Able to accept audio signal **via the SFP+ links** from the remote endpoint device;
- Able to accept audio signal **via the local HDMI in 2 port**;
- Able to **copy the signal of the HDMI out 1 port**. This is the **COPY** function.

HDMI Input Modes

The HDMI input ports of the receiver operate as local HDMI inputs.

Connection with an F110/F111/F120/F121/F130 Endpoint Device

When the F100/R100 receiver connects to an F110, F111, F120, F121 or F130 endpoint device, the number of audio inputs expands to three due to the analog audio input stream received via the SFP+ links. In this case the digital audio crosspoint changes to 3x2 (3 inputs and 2 outputs).

5.4.3. Transceiver Mode - F100 / R100 Models

Port Diagram

The port diagram is valid for the following UBEX endpoint model:

- UBEX-PRO20-HDMI-F100
- UBEX-PRO20-HDMI-R100 series

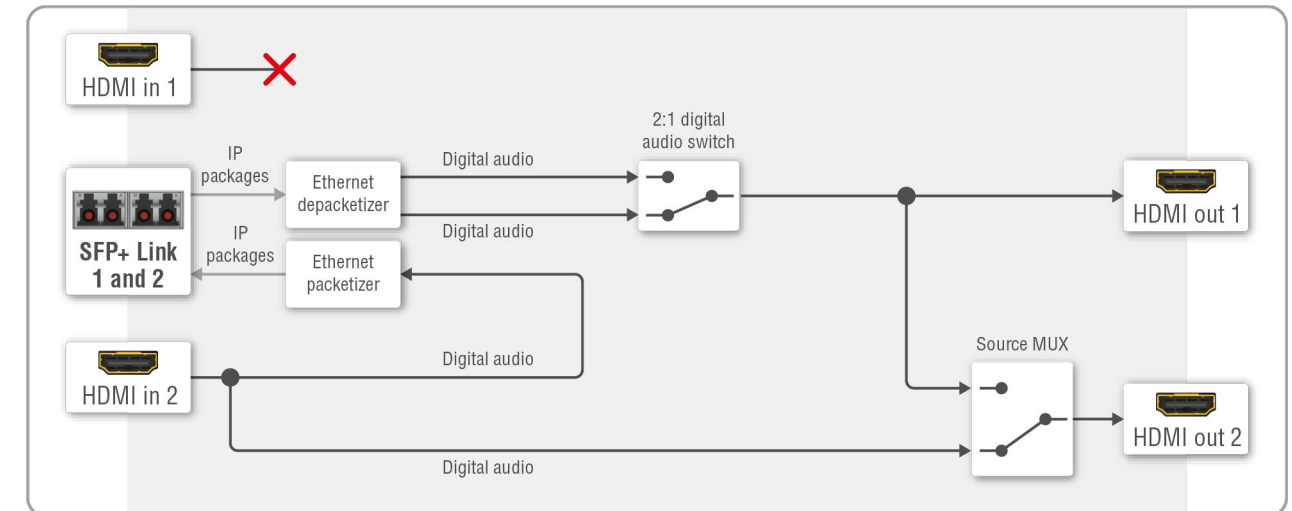

Audio port diagram of the F100/R100 transceiver in connection with an F110/F120 endpoint

Description

The transceiver can receive an HDMI audio stream via the SFP+ links and transmitting on the HDMI out 1 port.

The transceiver receives an HDMI audio signal via the HDMI input 2 port. The audio stream is transmitted toward the remote endpoint device over the SFP+ links.

In default state, the HDMI out 2 transmits the HDMI signal coming from the HDMI in 1 input port so it operates as a local output port.

The HDMI input 1 port of the transceiver cannot accept audio signals due to software limitation.

Source Multiplexer (MUX)

INFO: The source MUX function can be set on the video side only in the Lightware Device Controller (LDC) software, and using LW3 protocol commands as well.

The source multiplexer (**Source MUX**) makes routing several different source signals to the HDMI output 2 port available.

HDMI out 2

- Able to accept audio signal **via the local HDMI in 2 port**;
- Able to **copy the signal of the HDMI out 1 port**. This is the **COPY** function.

Connection with an F110/F111/F120/F121/F130 Endpoint Device

When the F100/R100 transceiver connects to an F110, F111, F120, F121 or F130 endpoint device, the port diagram changes due to the expanded audio possibilities.

The number of audio outputs expands to two due to the analog audio output port on the remote endpoint. The crosspoint setting is available in the local transceiver as well.

5.4.4. Transmitter Mode - F110/F111/F120/F121/F130 Models

Port Diagram

The port diagram is valid for the following UBEX endpoint models:

- UBEX-PRO20-HDMI-F110, -F111, -F120, -F121, -F130

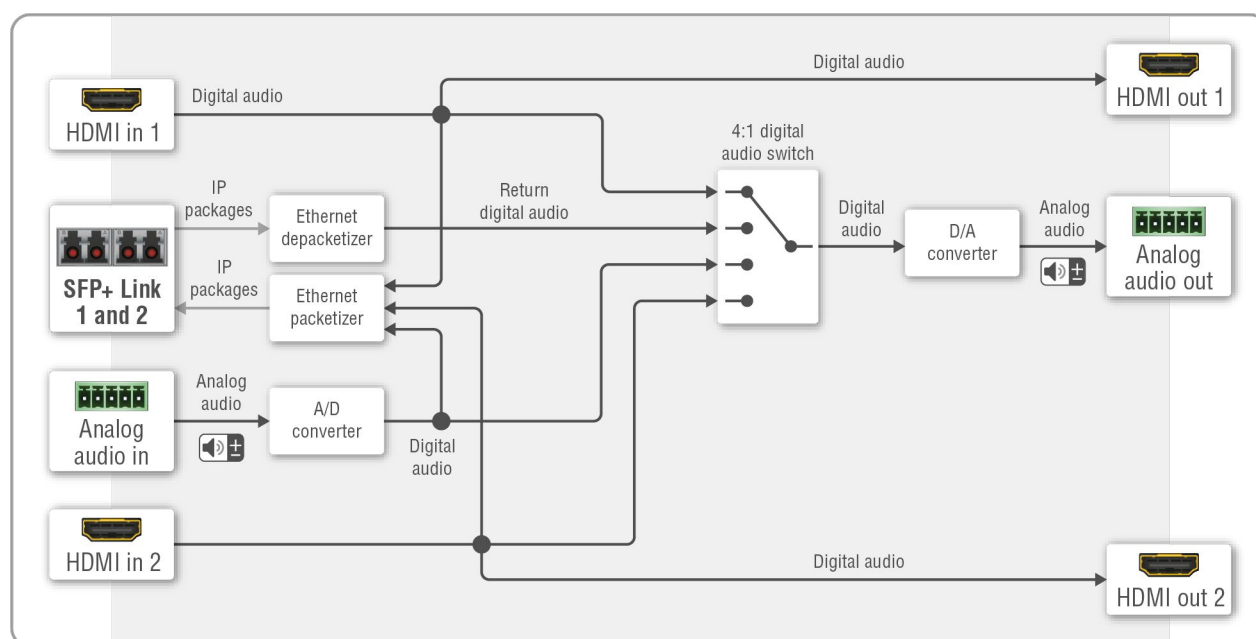

Audio port diagram of the F110 / F111 / F120 / F121 / F130 transmitter

Description

The device is built with a 4:1 digital audio switch, which has four inputs: the de-embedded digital audio streams of the HDMI in 1 and 2; the analog audio of the analog audio input port; and the return audio channel received from remote endpoint device over the SFP+ ports. The selected audio stream can be switched to the analog audio out port after a digital/analog conversion (D/A converter).

The audio streams of the HDMI in 1, HDMI in 2, and the analog audio in ports are transmitted via the SFP+ output ports toward the remote endpoint device.

The HDMI out 1 and 2 ports are local output ports, they transmit the audio streams of the HDMI in 1 and 2 ports directly.

Signal Support of the Analog Audio Output

The UBEX-PRO20-HDMI-F110, -F111, -F120, -F121 and -F130 endpoint models convert the **uncompressed stereo audio** stream to analog audio. The analog audio output port supports **PCM audio format up to 48 kHz**.

ATTENTION: If unsupported audio signal is selected to the analog audio output, the port will be muted automatically. The current status of the port can be queried by an LW3 protocol command, see the details in the [Query the Status of the Analog Audio Output](#) section.

5.4.5. Receiver Mode - F110/F111/F120/F121/F130 Models

Port Diagram

The port diagram is valid for the following UBEX endpoint models:

- UBEX-PRO20-HDMI-F110, -F111, -F120, -F121, -F130

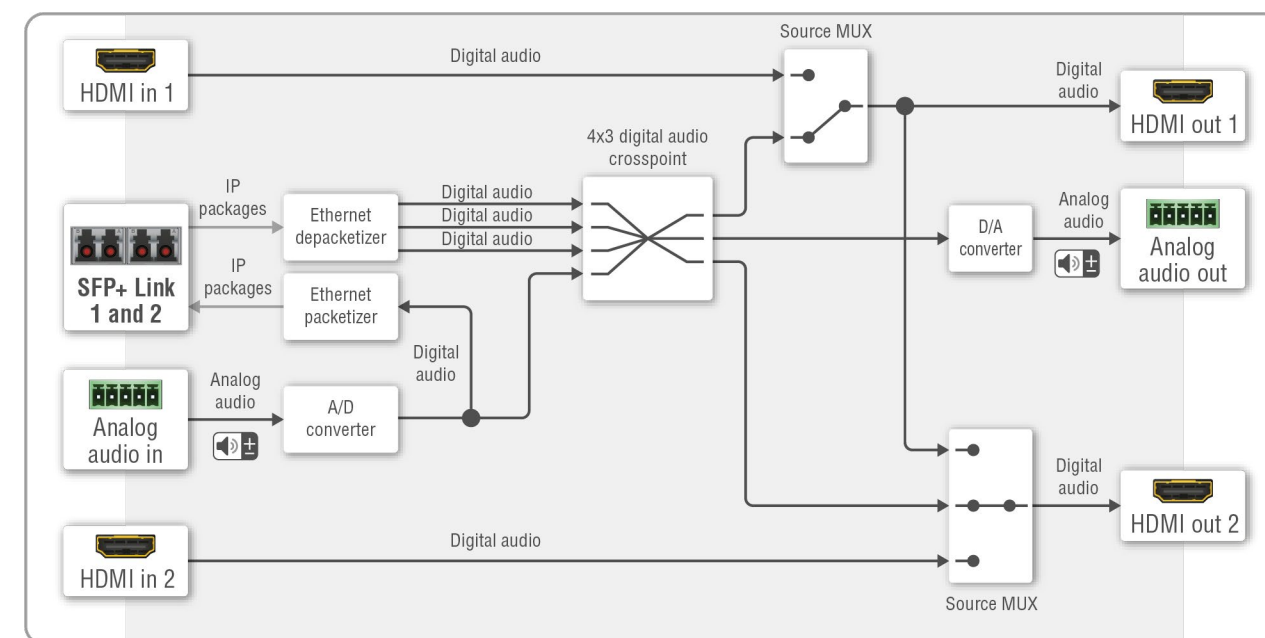

Port diagram of the F110 / F111 / F120 / F121 / F130 receiver

Description

The device is built with a 4x3 digital audio crosspoint, which has four inputs: three digital audio streams are received from the SFP+ links. The fourth input is the stream of the analog audio in port. The audio streams can be selected to the HDMI out 1 and 2, and the analog audio out ports.

The stream of the analog audio in port is transmitted toward the remote endpoint device over the SFP+ links.

The HDMI input ports of the receiver operate as local HDMI inputs.

Source Multiplexer (MUX)

INFO: The source MUX function can be set on the video side only in the Lightware Device Controller (LDC) software, and using LW3 protocol commands as well.

The source multiplexer (**Source MUX**) makes routing several different source signals to the HDMI output ports available. The type of sources is different by the two outputs.

HDMI out 1

- Able to accept audio signal **via the SFP+ links** from the remote endpoint device;
- Able to accept audio signal **via the local HDMI in 1** port.

HDMI out 2

- Able to accept audio signal **via the SFP+ links** from the remote endpoint device;
- Able to accept audio signal resolution **via the local HDMI in 2** port;
- Able to **copy the signal of the HDMI out 1** port. This is the **COPY** function.

HDMI Input Modes

The HDMI input ports of the receiver operate as local HDMI inputs.

Signal Support of the Analog Audio Output

The UBEX-PRO20-HDMI-F110, -F111, -F120, -F121 and -F130 endpoint models convert the **uncompressed stereo audio** stream to analog audio. The analog audio output port supports **PCM audio format up to 48 kHz**.

ATTENTION: If unsupported audio signal is selected to the analog audio output, the port will be muted automatically. The current status of the port can be queried by an LW3 protocol command, see the details in the [Query the Status of the Analog Audio Output](#) section.

5.4.6. Transceiver Mode - F110/F111/F120/F121/F130 Models

Port Diagram

The port diagram is valid for the following UBEX endpoint model:

- UBEX-PRO20-HDMI-F110
- UBEX-PRO20-HDMI-F111
- UBEX-PRO20-HDMI-F120
- UBEX-PRO20-HDMI-F121
- UBEX-PRO20-HDMI-F130

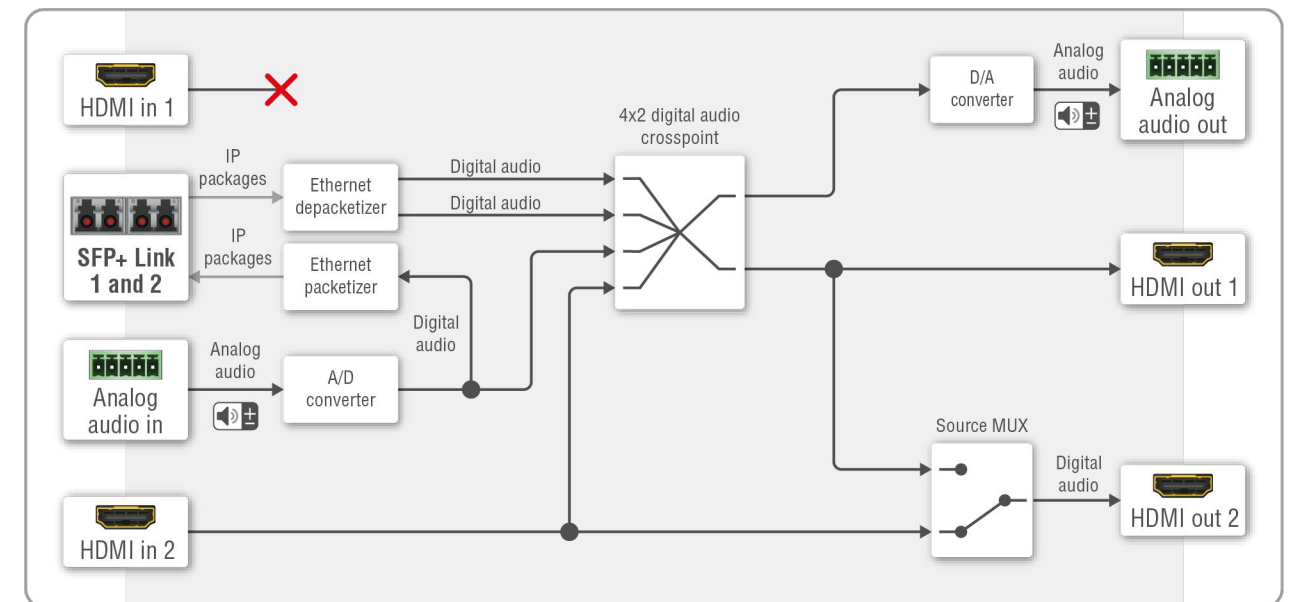

Port diagram of the F110 / F111 / F120 / F121 / F130 transceiver

Description

The device is built with a 4x2 digital audio crosspoint, which has four inputs: two of them are received on the SFP+ links; the stream of the analog audio in, and the stream of the HDMI in 2 port. Any audio can be selected to the HDMI out 1 and the analog audio out ports.

The audio streams of the HDMI in 2 and the analog audio in ports are transmitted via the SFP+ output ports toward the remote endpoint device.

In default state, the HDMI out 2 port is a local output port, it transmits the audio stream of the HDMI in 2 port directly.

The HDMI input 1 port does not accept signal when the device is configured as transceiver.

Source Multiplexer (MUX)

INFO: The source MUX function can be set on the video side only in the Lightware Device Controller (LDC) software, and using LW3 protocol commands as well.

The source multiplexer (**Source MUX**) makes routing several different source signals to the HDMI output 2 port available.

HDMI out 2

- Able to accept audio signal **via the local HDMI in 2 port**;
- Able to **copy the signal of the HDMI out 1 port**. This is the **COPY** function.

Signal Support of the Analog Audio Output

The UBEX-PRO20-HDMI-F110, -F111, -F120, -F121 and -F130 endpoint models convert the **uncompressed stereo audio** stream to analog audio. The analog audio output port supports **PCM audio format up to 48 kHz**.

ATTENTION: If unsupported audio signal is selected to the analog audio output, the port will be muted automatically. The current status of the port can be queried by an LW3 protocol command, see the details in the [Query the Status of the Analog Audio Output](#) section.

5.4.7. Audio Signal Transmission - Example for TX-RX Pair

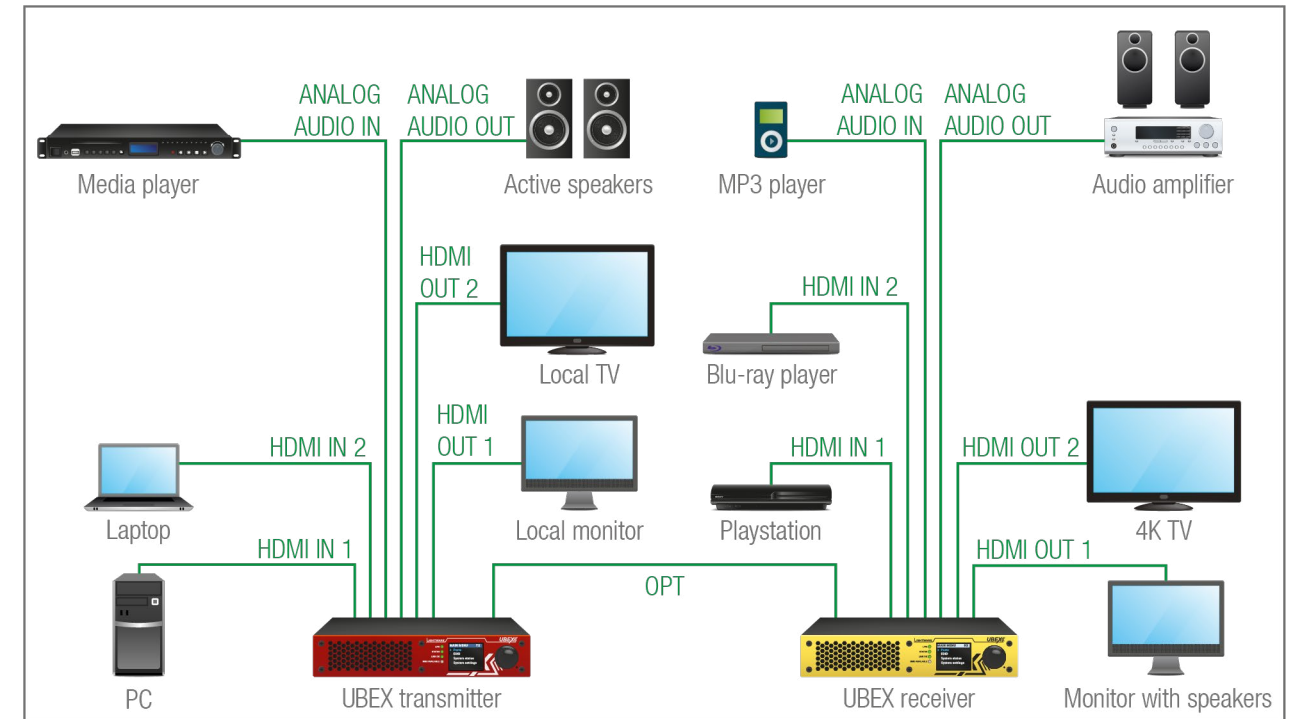

The Concept

Three source devices are connected to the F120 transmitter: a PC and a laptop on the HDMI input ports; and a media player on the analog audio input port. A sink device is also connected to the transmitter: active speakers on the analog audio output port. Local sink devices are plugged into the HDMI out 1 and 2 ports of the transmitter where the transmitted signals can be checked.

The F121 receiver has three sink devices: a monitor with speakers and a 4K TV on the HDMI output ports; and an audio amplifier on the analog audio output port. A source device is also connected to the receiver: an MP3 player on the analog audio input port.

The following chart shows all audio stream selection possibilities:

		Destinations						
		Transmitter			Receiver			
		HDMI out 1 Local TV	HDMI out 2 Local monitor	Analog audio out Active speakers	HDMI out 1 HD monitor	HDMI out 2 4K TV	Analog audio out Audio amplifier	
Sources	Transmitter	HDMI in 1 PC	✓	-	✓	✓	✓	✓
		HDMI in 2 Laptop	-	✓	✓	✓	✓	✓
		Analog audio in Media player	-	-	✓	✓	✓	✓
	Receiver	HDMI in 1 Playstation	-	-	-	✓	-	-
		HDMI in 2 Blu-ray player	-	-	-	-	✓	-
		Analog audio in MP3 player	-	-	✓	✓	✓	✓
		Copy of the HDMI out 1	-	-	-	-	✓	-

Summary: All audio streams of the source devices can be selected to all sink devices except:

- The local HDMI outputs of the transmitter, which are always in sync with the audio signals of the transmitter's inputs;
- The local HDMI inputs of the receiver, which can be always selected to the receiver's outputs.

5.4.8. Audio Signal Transmission - Example for TRX-TRX Pair

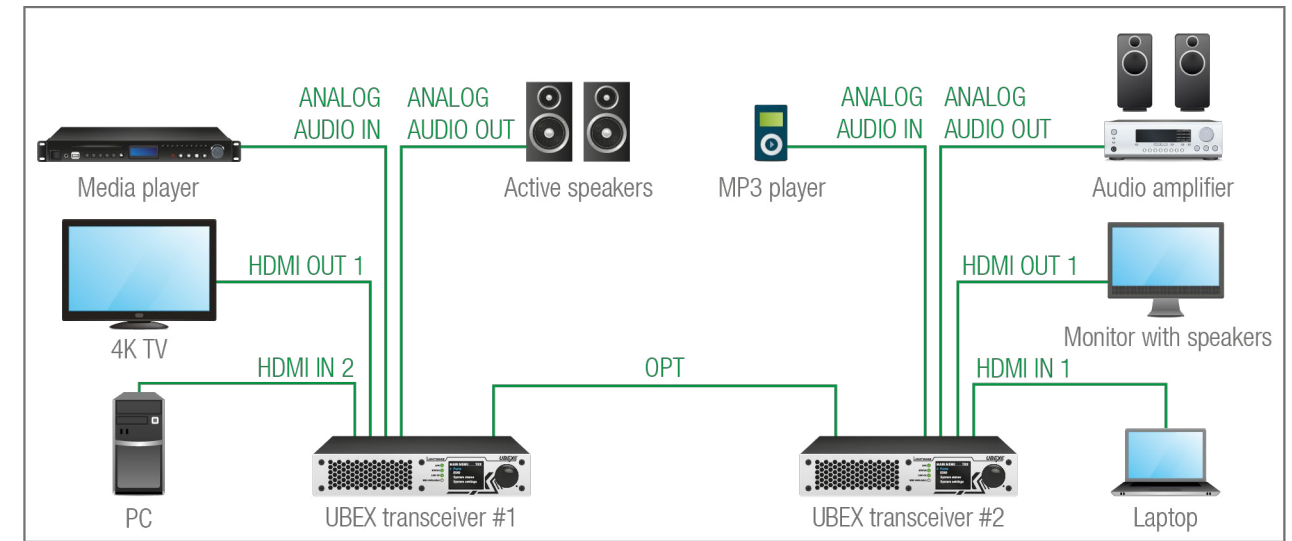

The Concept

Two source devices are connected to the F130 transceiver #1: a PC on the HDMI input 2 port; and a media player on the analog audio input port. Two sink devices are also connected to the endpoint: a 4K TV on the HDMI output 1 port; and active speakers on the analog audio output port.

The configuration of the F130 transceiver is similar. Two source devices are connected: a laptop on the HDMI input 2 port; and an MP3 player on the analog audio input port. Two sink devices are also connected to the endpoint: a monitor with speakers on the HDMI output 1 port; and audio amplifier on the analog audio output port.

The following chart shows all audio stream selection possibilities:

Crosspoint possibilities of the audio streams for UBEX			Sink devices			
			Transceiver #1		Transceiver #2	
			4K TV	Active speakers	Monitor with speakers	Audio amplifier
Sources	TRX #1	PC	✓	✓	✓	✓
		Media player	✓	✓	✓	✓
	TRX #2	Laptop	✓	✓	✓	✓
		MP3 player	✓	✓	✓	✓

Summary: All audio streams of the source devices can be selected to all sink devices except the local HDMI outputs of the transmitter, which can be always selected to the inputs; and the local HDMI inputs of the receiver, which can be always selected to the outputs.

5.5. Ethernet Control Interface

The endpoint device can be controlled via Ethernet port. This interface supports any third-party system controller with LW3 command protocol. The interface can be used to configure the device with Lightware Device Controller and establish the connection to Lightware Device Updater software and perform firmware update.

Two Ethernet connectors provide a wide range of application possibilities:

- Control the device
- Firmware update
- Create a local network
- Daisy chain connection

Port Diagram

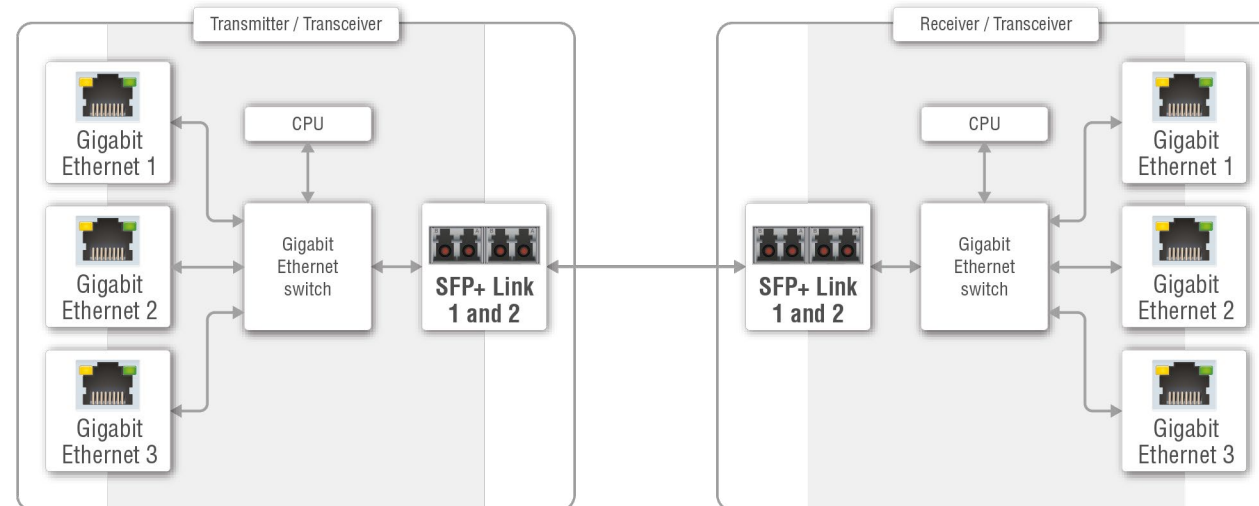

Port diagram of the Ethernet interface for the F110 / F120 / F130 model

Number of the Gigabit Ethernet Ports

The following table shows the number of the Gigabit Ethernet ports by endpoint models.

Endpoint model	Number of Gigabit Ethernet ports
UBEX-PRO20-HDMI-F100	2
UBEX-PRO20-HDMI-F110, -F111, -F120, -F121, -F130	3
UBEX-PRO20-HDMI-R100 2xMM-2xDUO	1
UBEX-PRO20-HDMI-R100 2xSM-2xDUO	1
UBEX-PRO20-HDMI-R100 2xMM-QUAD	2
UBEX-PRO20-HDMI-R100 2xSM-QUAD	2
UBEX-PRO20-HDMI-R100 2xSM-BiDi-DUO	2

Ethernet Interface - Example

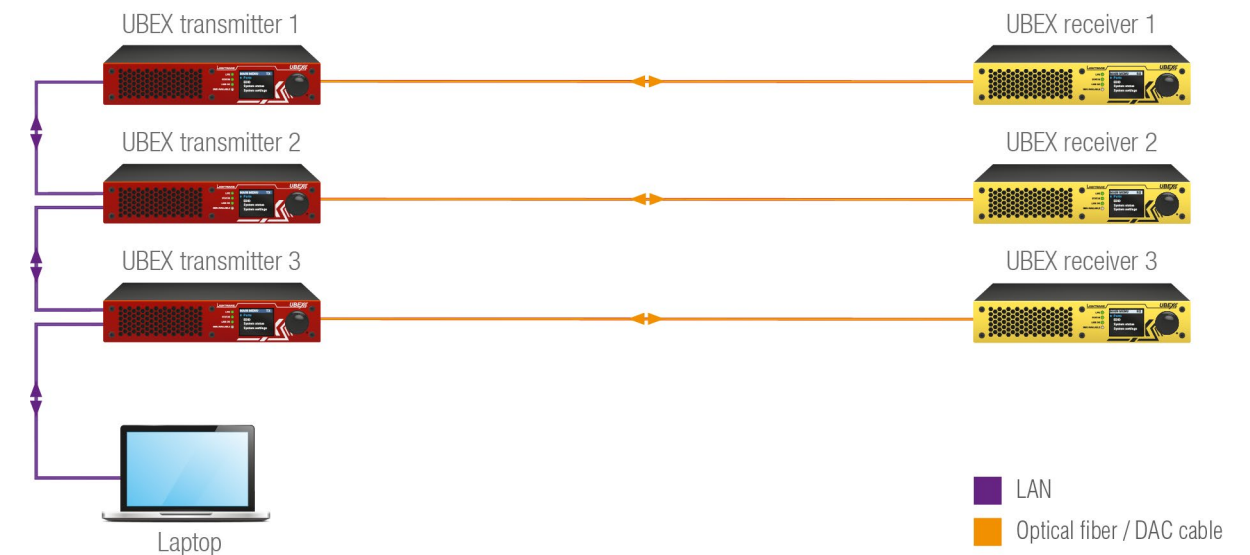

The **transmitters** are connected to each other via LAN, the **receivers** are connected to the **transmitters** via optical fiber or DAC cables.

This way the **laptop** can control the system with Ethernet commands:

- UBEX transmitter (1-3).
- UBEX receiver (1-3).

ATTENTION: When one of the extenders is in firmware update mode, the Ethernet communication will be lost during the update procedure.

5.6. Serial Interface

DIFFERENCE: Only the UBEX-PRO20-HDMI-F110, -F111, -F120, -F121 and -F130 models are built with serial interface port.

5.6.1. Technical Background

Port Diagram

The Concept

The endpoint device uses **command injection**, which means in the practice it works as a TCP/IP -> RS-232 converter so the TCP/IP data signal is converted to RS-232 data. The serial message is sent over the Ethernet interface (via the Gigabit Ethernet 1-3 ports), which addresses the local or the remote RS-232 port. TCP/IP port numbers are defined for the serial ports for this purpose. E.g. the default Command Injection port number of the local RS-232 port is 8001. If data is coming from the SFP+links that is addressed to the port no. 8001, it will be transmitted to the Tx pin of the local RS-232 port.

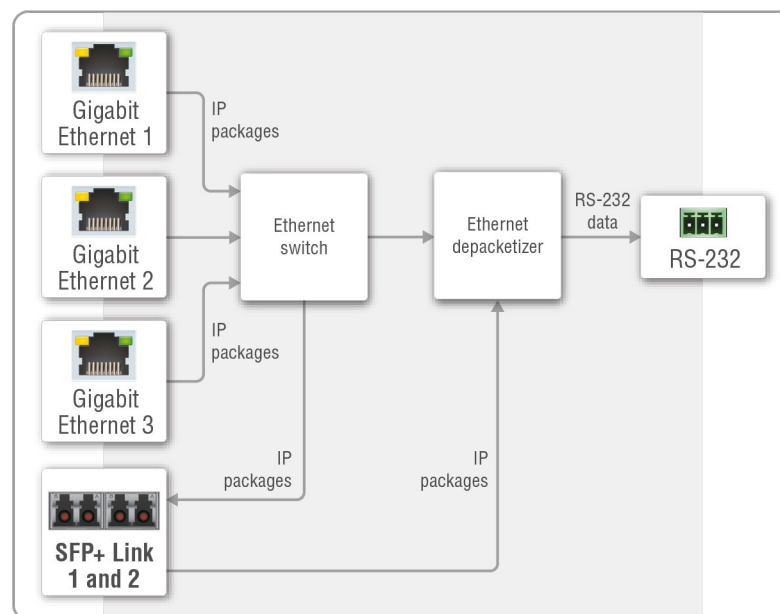

5.6.2. RS-232 Signal Transmission – Example

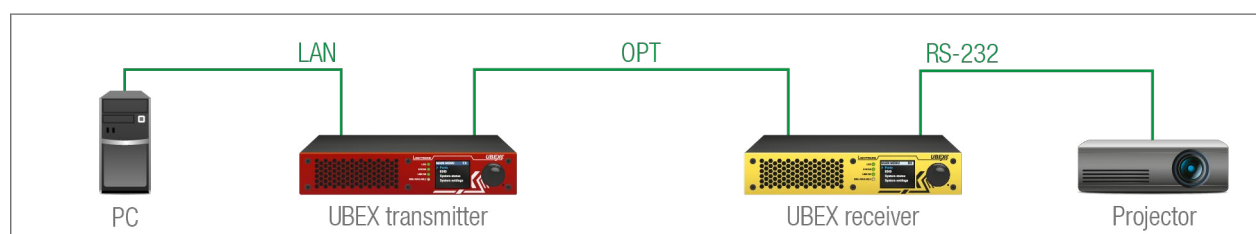

The Concept

The projector that is connected to the UBEX receiver is controlled with RS-232 messages, which are sent from the PC connected to the UBEX transmitter. You can send serial messages in text, hexa, and binary format using two methods:

- **Lightware Device Controller (LDC)** - see the details in the [RS-232 Tab](#) section;
- **LW3 protocol commands** - see the details in the [Message Sending via Communication Ports](#) section.

5.7. Infrared Interface

DIFFERENCE: Only the UBEX-PRO20-HDMI-F110 and F120 models have built with Infrared interface ports.

ATTENTION: The device has no built-in Infrared receiver and transmitter. For the complete usage, attach the supplied IR emitter unit to the IR OUT and the IR detector unit to the IR IN connectors.

5.7.1. Technical Background

Port Diagram

The endpoint device uses **command injection**, which means in the practice it works as a TCP/IP -> Infrared converter, so the TCP/IP data signal is converted to Infrared code. The Infrared code can be received from the IR in port or it is sent over the Ethernet interface (via the Gigabit Ethernet 1-3 ports), which addresses the IR out port of the remote endpoint device. TCP/IP port numbers are defined for the IR output port for this purpose. E.g. the default Command Injection port number of the IR out port is 9002. If data is coming from the SFP+links that is addressed to the port no. 9002, it will be transmitted to the IR output port.

INFO: The modulation of output IR signal can be turned off or on by LW3 protocol command, see the [Enable/Disable Output Signal Modulation](#) section.

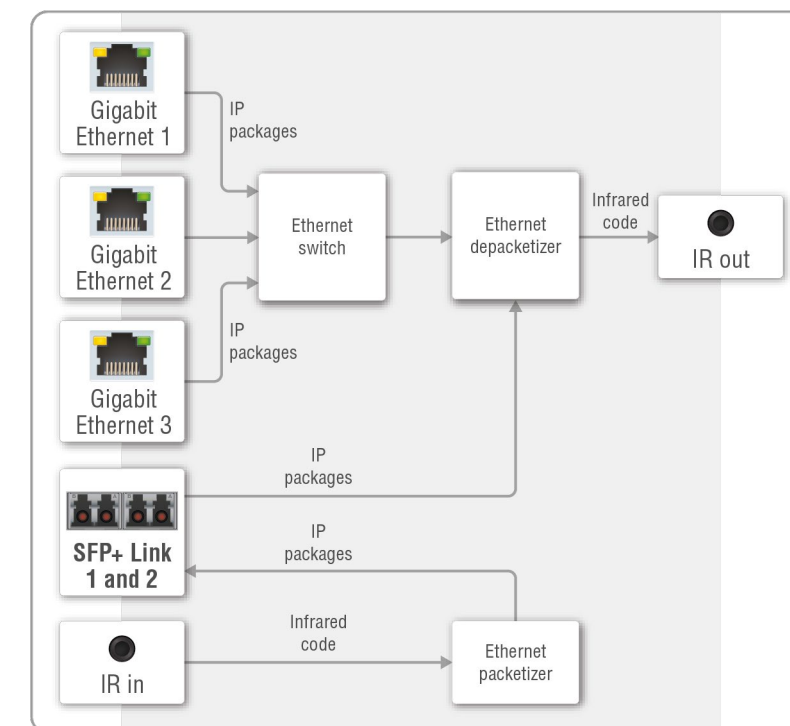

Infrared Message Sending

Infrared message can be sent over the IR output port in two formats:

- Pronto hex message in **little-endian format** using LDC (see the details in the [Infra Tab](#) section) or LW3 protocol command (see the details in the [Sending Hex Codes in Little-endian Format via IR Port](#) section);
- Pronto hex message in **big-endian format** using LW3 protocol command (see the details in the [Sending Hex Codes in Big-endian Format via IR Port](#) section).

5.7.2. Infrared Signal Transmission - Example

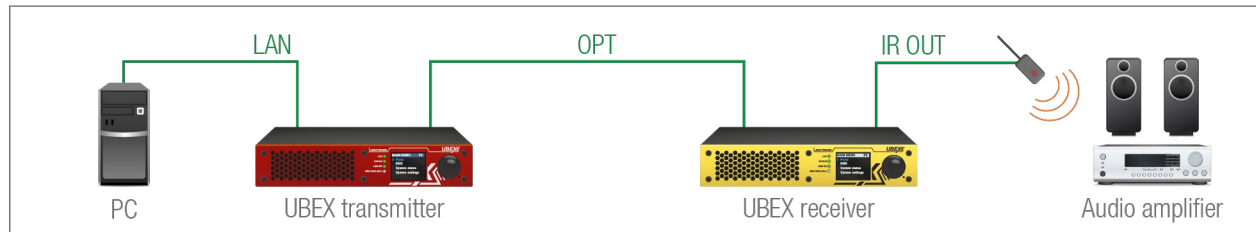

The Concept

The IR code is sent from the PC over LAN, where the message addresses the port number of the IR output port of the receiver. The audio amplifier is controlled remotely by the IR signal.

5.8. USB K+M Interface (F120 and F121 Models)

DIFFERENCE: Only UBEX-PRO20-HDMI-F120 and -F121 models are built with USB K+M ports.

DIFFERENCE: The Host port of the F121 model has USB-C connector, the F120 model is built with USB-B connector.

5.8.1. Technical Background

Port Diagram

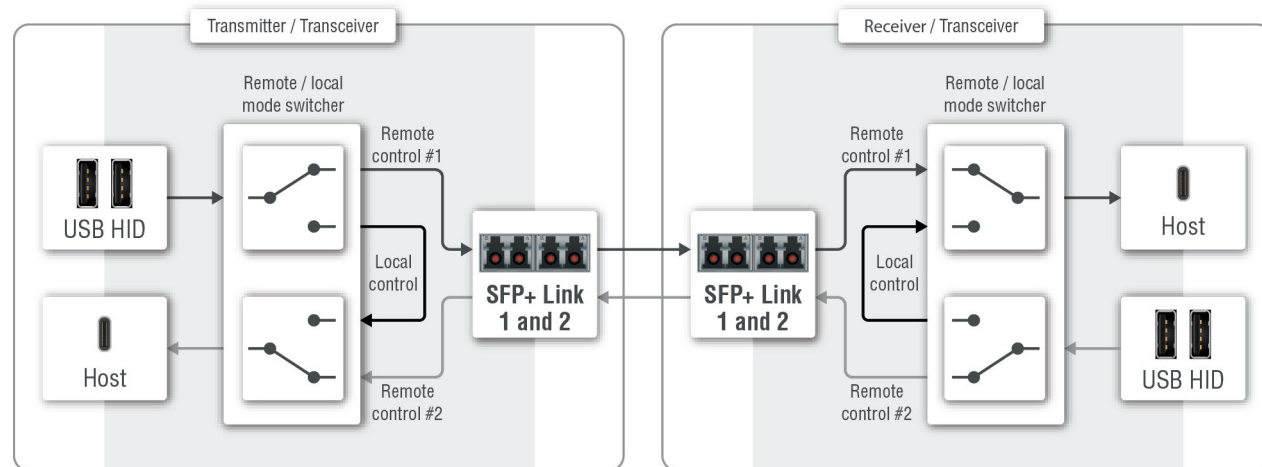

Port diagram of the USB K+M interface for the F120 / F121 model

Two connected F120 devices are able to transfer USB K+M signal via the SFP+ links. Two working methods are available: **remote control** and **local control**. Remote control means the K+M signals are transmitted to the connected device; the local control means the K+M signal affects the controlled device connected locally to the extender.

The USB K+M function supports **emulated (composite) mode only**. It means in the practice the perfect usage of special keyboard/mouse buttons (e.g. multimedia keyboards and touchpads) are not guaranteed because of the limitation of the emulated mode technology. Lightware recommends usage of ordinary keyboards built up to 104/105 keys and ordinary mice.

ATTENTION: Webcameras and other high bandwidth demand devices are **not supported** by the USB ports.

INFO: F120 and F121 models allow to connect **USB HUB** to the USB-A (K+M) ports. It gives an opportunity to make more USB HID device connections. Please note that information about the connected USB HID devices cannot be read out by the extender via the USB HUB.

INFO: Both types of USB ports (USB-A and USB-B) are working in all operation modes (TX, RX and TRX) as well.

5.8.2. USB K+M Extension - Example

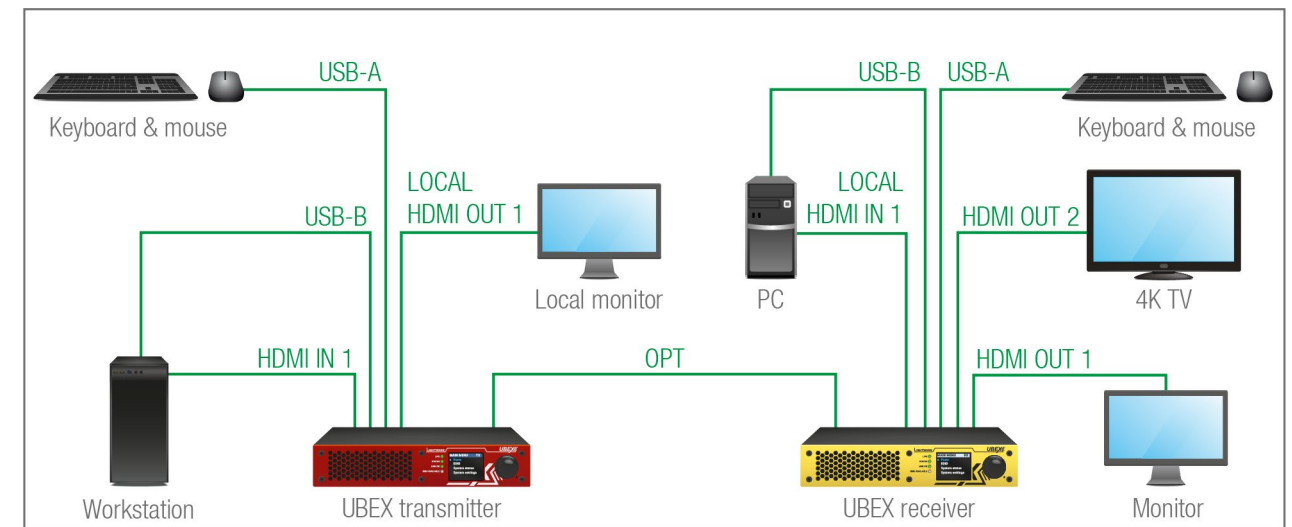

The Concept

A transmitter and a receiver is connected over the SFP+ links. Host (workstation, PC) and controller (keyboards & mice) devices are connected to both extenders.

When the extenders are in remote control mode, the workstation connected to the transmitter can be controlled via the keyboard & mouse connected to the receiver.

When the extenders are in local control mode, the workstation can be controlled via the keyboard and mouse connected to the transmitter; and the PC can be controlled via the keyboard and mouse connected to the receiver - in this case the AV crosspoint is needed to set to the Local HDMI input.

The USB K+M modes can be set using two methods:

- **Lightware Device Controller (LDC)** - see the details in the [USB Tab](#) section;
- **LW3 protocol commands** - see the details in the [USB K+M Settings \(F120 / F121 Models\)](#) section.

5.9. USB KVM / USB 2.0 Interface (F130 Model)

DIFFERENCE: Only UBEX-PRO20-HDMI-F130 model is built with USB KVM and USB 2.0 feature.

5.9.1. Technical Background

Port Diagram

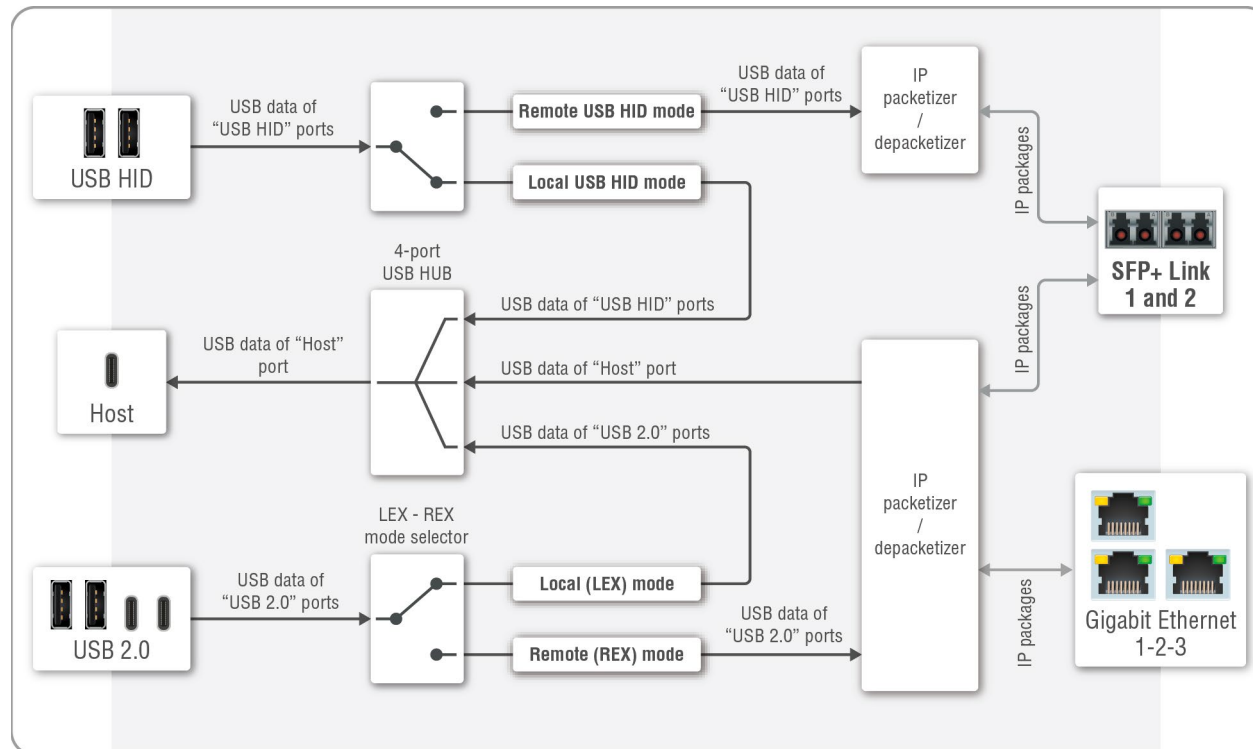

Port diagram of the USB KVM and USB 2.0 feature of the F130 model

Ports

UBEX-PRO20-HDMI-F130 model is built with a **Host** port (USB-C) for the host device (e.g. a computer), two **USB HID** ports (2x USB-A) for the HID devices (e.g. keyboard, mouse, presenter) and four **USB 2.0** ports (2x USB-A; 2x USB-C) for the user's USB 2.0 devices (e.g. mass storage, web camera, microphone, etc).

ATTENTION: USB-C ports receive USB data only, no AV signal transmission is accepted. It supports USB 2.0 standard only.

Operation of USB HID Ports

There are two operation modes of the USB HID ports:

- **Local mode** - the local host device (e.g. a computer) that is connected to the local Host port can be controlled by the local HID devices (e.g. keyboard, mouse, presenter).
- **Remote mode** - the remote host device (e.g. a computer) that is connected to the remote Host port of the connected F130 extender can be controlled by the local HID devices (e.g. keyboard, mouse, presenter). The USB signal is transmitted over the **SFP+ link 1 and 2 only**.

ATTENTION: In case of **remote mode** the USB KVM transmission **always reserves 2 Gbps bandwidth** so the available total bandwidth is **8 Gbps** in case of 1x10G SFP+ connection and **18 Gbps** in case of 2x10G SFP+ connection. See more details about the bandwidth calculation for this model in the [F130 Endpoint Model](#) section.

The operation mode can be set using the following methods:

- **Lightware Device Controller (LDC)** - see the details in the [USB Tab](#) section;
- **LW3 protocol commands** - see the details in the [Switching the Emulated Port to the Remote Receiver](#) and the [Switching the Local Emulated Port to the Local Receiver](#) sections.

Operation of USB 2.0 Ports

There are two operation modes of the USB 2.0 ports:

- **Local (LEX) mode** - the ports are mounted on the connected local host device (e.g. a computer) via the local Host port. The ports appear as extended USB devices like a connected mass storage.
- **Remote (REX) mode** - the ports are mounted on the connected remote host device (e.g. a computer) via **SFP+ link 1 and 2** or the **Gigabit Ethernet 1-2-3** ports.
- **Disabled mode** - the USB 2.0 ports are disabled. In this mode there is no bandwidth reservation, see the attention section below.

ATTENTION: The USB KVM and the USB 2.0 transmission **reserves 2 Gbps bandwidth** also in LEX and REX modes, so the the available total bandwidth is **8 Gbps** in case of 1x10G SFP+ connection and **18 Gbps** in case of 2x10G SFP+ connection. In case of **disabled mode**, this **restriction is ceased** and the available bandwidth is up to 20 Gbps. See more details about the bandwidth calculation for this model in the [F130 Endpoint Model](#) section.

INFO: In case of **remote (REX) mode** the compatible Icron USB devices can be discovered over the SFP+ link and **over the Gigabit Ethernet links** as well. The connected devices can be UBEX extenders or any compatible third-party Icron device.

INFO: The **Host** USB-C port receives **USB data only**, no AV signal transmission is accepted. It supports **USB 2.0 standard only**.

The operation mode can be set using the following method:

- **LW3 protocol commands** - see the details in the [Setting the Operation Mode of the Icron USB 2.0 Module](#) section.

INFO: The operation mode of the USB HID and USB 2.0 ports **can be set separately**.

5.9.2. Pairing the Icron Devices

There are two methods available pairing the Icron USB 2.0 modules:

- by using the **Switchable USB** protocol command - see the details in the [Pairing to a Device](#) section;
- by using **LARA** (Lightware Automation Room Application) modules.

LARA Icron Module

The LARA Icron USB 2.0 module provides discovery and pairing of the Icron devices on the network. User interfaces for computers or touchscreens can be configured and personalized for the easy graphical access to the USB 2.0 features.

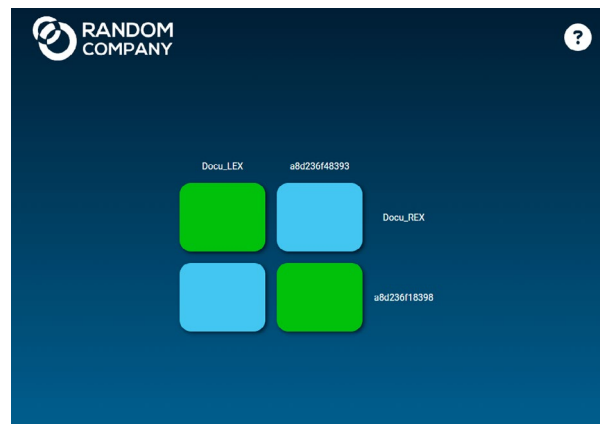

Crosspoint UI of a sample 2x2 Icron USB 2.0 matrix system

LARA is embedded into the firmware package of several Lightware product families:



See the detailed step-by-step descriptions about the configuration of the LARA Icron modules in the LARA user manual: <https://go.lightware.com/lara-pum>

Learn more about LARA in the dedicated homepage on the Lightware website:

<https://www.lightware.com/en/products/Software/lara-software>

5.9.3. USB KVM and USB 2.0 Extension - Example

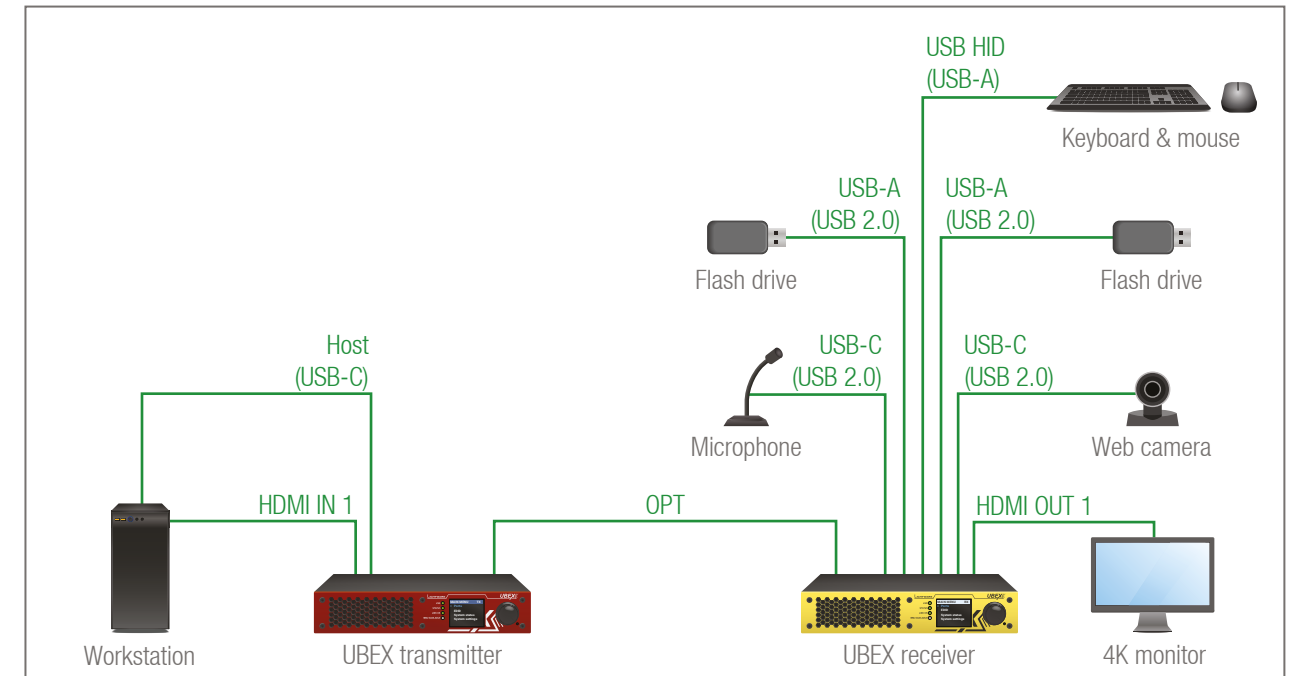

The Concept

A transmitter and a receiver is connected over the SFP+ links. A Host device (workstation) is connected to the transmitter and four USB 2.0 (2x flash drive, microphone, web camera) and controller (keyboards & mouse) devices are connected to the receiver, the AV signal and the USB data signals are transmitted over the SFP+ links.

The settings of the **transmitter** are the following:

- USB HID ports: **Local** mode
- USB 2.0 ports: **Local (LEX)** mode

The settings of the **receiver** are the following:

- USB HID ports: **Remote** mode
- USB 2.0 ports: **Remote (REX)** mode

5.10. SFP+ Interface

DEFINITION: SFP+: the enhanced small form-factor pluggable (SFP+) is an enhanced version of the SFP that supports data rates up to 10 Gbit/s.

The F-series endpoint devices are built with 2x 10 GbE SFP+ ports to transmit the video streams between the receiver and the transmitter, or between two transceivers.

The following methods can be applied to connect the endpoint devices to each other:

- 2x SFP+ transceiver module up to 10Gbps bandwidth/module. The modules can be singlemode or multimode, built with LC duplex connectors or BiDi modules; or SFP+ to RJ45 modules with copper solution. The maximum allowed fiber optical cable length depends on the installed SFP+ modules. Always check the specification of the module.
- 2x 10GbE DAC cable

ATTENTION: Always apply **equal length** copper cables for both SFP+ to RJ45 modules in case of 20G signal transmission. Different cable lengths may cause data package loss. See more information about the applicable cable lengths and types in the [Maximum Cable Extensions](#) section.

INFO: The maximum available bandwidth with the endpoint device is 20 Gbps, which requires 2x 10 GbE SFP+ module or DAC cable to install. If one 10 GbE SFP+ module is installed only, but the signal is 4K@60 Hz (which requires 14 Gbps to transmit), the signal transmission will be disabled. See more details about it in the [Bandwidth Limitation](#) section.

INFO: For more details of the installation steps of SFP+ modules and DAC cables, see the [SFP+ Slot Connection](#) section.

INFO: In case of SFP+ to RJ45 module installation, the endpoint device sets the **cooling fans** to (minimum) **2500 rpm** automatically.

5.11. Redundant 10G Link Channels

The UBEX F-series and R-series endpoint models are built with two equivalent 10 GbE Ethernet channels, which are based on a redundant operating principle. It means both 10 GbE Ethernet connections are able to take the place of the other one in case of a connection loss. For example, if one of the two SFP+ modules is pulled out during the operation, the AV transmission keeps going.

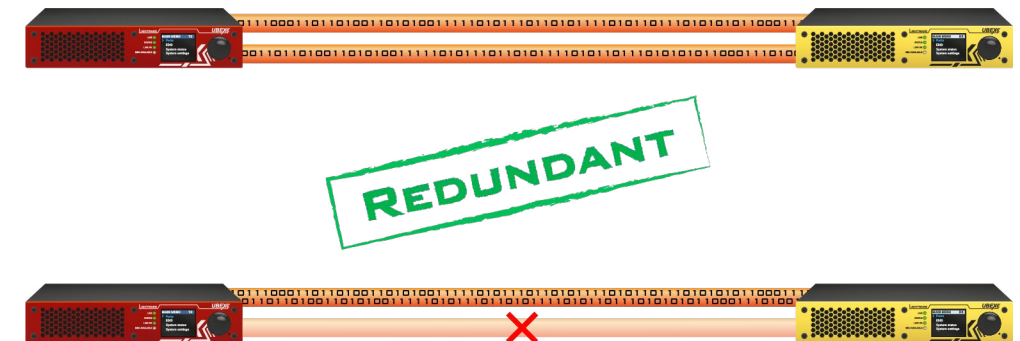

ATTENTION: The optical connection redundancy is available only in case of one or two HDMI signals where the sum of the required bandwidth is not greater than 10 Gb/s. Please check the [Bandwidth Requirements of the Resolutions](#) section for the details.

INFO: If two HDMI signals are transmitted where the sum of the bandwidth is greater than 10 Gb/s, there are limitations in the signal transmission on both the transmitter and the receiver side. See more details about it in the [Bandwidth Limitation](#) section.

INFO: Redundancy is available in case of fiber optical and copper (RJ45) connections as well.

5.12. Further Built-in Features

5.12.1. Device Cloning – Configuration Backup and Restore

The device (configuration) cloning of UBEX series extender is a simple method that eliminates the need to repeatedly configure certain devices to have identical (non-factory) settings. If the devices are installed in the same type of system multiple times, then it is enough to set up only one device to fit the user's needs and then copy those settings to the others, thus saving time and resources.



See more information about the settings in the [Configuration Cloning \(Backup Tab\)](#) section.

ATTENTION: The configuration restore procedure works on the **same type of operation modes only**.

5.12.2. Advanced EDID Management

Factory Preset EDIDs

The factory EDIDs (F1-F148) are factory preprogrammed and cannot be modified. These are the most common signal formats. They are specially provided to force graphic cards to output only the exact pixel resolution and refresh rate.

Universal EDID allows multiple signal formats, including all common VESA defined resolutions. The use of universal EDID is recommended for fast and easy system setup.

Sources and Destinations

The EDID memory consists of four parts:

- **Factory EDID** list shows the pre-programmed EDIDs (F1-F148).
- **Dynamic EDID** list shows the sinks connected to the device's outputs (D1-D4). The unit stores the last display devices' EDID on either output, so there is an EDID shown even if there is no display device attached to the output port at the moment.
- **User memory** locations (U1 – U12) can be used to save custom EDIDs.
- **Emulated EDID** list shows the currently emulated EDID for the inputs (E1-E2). The source column displays the memory location that the current EDID was routed from.

The source reads the EDID from the Emulated EDID memory on the input port. Any EDID from any of the User/Factory/Dynamic EDID lists can be copied to the user memory.

There are two types of emulation: **static** and **dynamic**.

- **Static EDID emulation:** an EDID from the Factory or User EDID list is selected. Thus, the Emulated EDID remains the same until the user emulates another EDID.
- **Dynamic EDID emulation:** it can be enabled by selecting D1-D4 EDID memory. The attached monitor's EDID is copied to the input; if a new monitor is attached to the output, the emulated EDID changes automatically.

See more information about the settings in the [EDID Management Menu](#) section in the LDC software.

5.13. Software Control Modes

User has more possibilities to control the device besides the front panel LCD screen. The following list contains the software control modes:

- **Lightware Device Controller (LDC)** - you can connect to the device via our control software using Ethernet interface and control or configure the device as you wish. For the details, see the [Software Control - Lightware Device Controller](#) chapter.
- **LW3 protocol commands:** you can configure the device by using the full-range command set of LW3 protocol. For more details, see the [Programmers Reference](#) chapter.

6

Software Control - Lightware Device Controller

The device can be controlled by a computer through Ethernet interface with the Lightware Device Controller (LDC). The software can be installed on a Windows PC or macOS. The application and the User Manual can be downloaded from www.lightware.com.

▶ Install and Update	90
▶ Running the LDC	90
▶ Establishing the Connection	91
▶ Video Crosspoint Menu	92
▶ Properties Windows - Video Layer	94
▶ Audio Crosspoint Menu	100
▶ Properties Windows - Audio Layer	101
▶ Diagnostic Tools	102
▶ EDID Management Menu	103
▶ Control Menu	106
▶ Settings Menu	109
▶ Configuration Cloning (Backup Tab)	111
▶ Terminal Window	112

6.1. Install and Update

INFO: After the installation the Windows and the macOS application has the same look and functionality.

Minimum System Requirement

RAM: 1 GB

Minimum display resolution: 1280x720

Installation for Windows OS

Run the installer. If the User Account Control drops a pop-up message, click **Yes**.

During the installation you will be prompted to select the type of the installation: **normal** and the **snapshot** install:

Normal install	Snapshot install
Available for Windows and macOS	Available for Windows
The installer can update only this instance	Cannot be updated
Only one updateable instance can exist for all users	More than one different version can be installed for all users

Comparison of installation types

ATTENTION: Using the Normal install as the default choice is highly recommended.

Installation for macOS

Mount the DMG file by double clicking on it, and drag the LDC icon over the Applications icon to copy the program into the Applications folder. If you want to copy the LDC into another location just drag the icon over the desired folder.

ATTENTION: Please check the **firewall settings** on the macOS device. LDC needs to be added to the exceptions of the blocked software for the proper operation.

Updating of LDC

Step 1. Run the application.

The **Device Discovery** window appears automatically, and the program checks the available updates on Lightware's website and opens the update window if LDC updates are found.

The current and the update version number can be seen at the top of the window, and they are shown in this window even with the snapshot install.

The **Update** window can also be opened by clicking on the **About**  icon and the **Update** button.

Step 2. Set the desired update setting in the **Options** section.

- If you do not want to check for the updates automatically, uncheck **the circle** that contains the green tick.
- If you want to postpone the update, a reminder can be set with different delays from the **drop down list**.
- If the proxy settings traverse the update process, set the proper values, then click on the **OK** button.

Step 3. Click on the **Download update** button to start the updating.

The updates can be checked manually by clicking on the **Check now** button.

6.2. Running the LDC

The common way to start the software is to double-click on the LDC icon. But the LDC can also be run by command line parameters as follows:

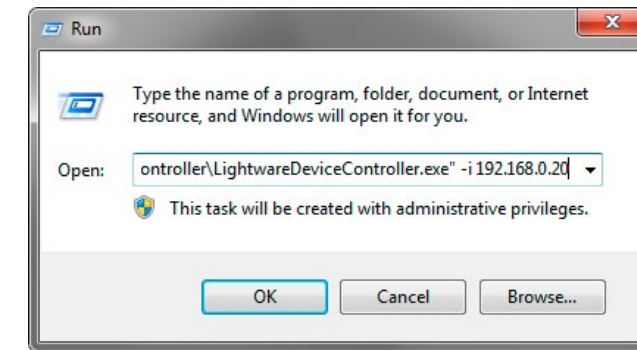

Launching of LDC in a Run window in Windows operating system

Connecting to a Device with Static IP Address

Format: LightwareDeviceController -i <IP_address>:<port>

Example: LightwareDeviceController -i 192.168.0.20:6107

The LDC is connected to a device with the indicated static IP address directly; the Device Discovery window is not displayed. When the port number is not set, the default port is used: 10001 (LW2 protocol - not supported by the UBEX extenders). For LW3 devices, use the **6107** port number.

Adjusting the Zoom

The window can be zoomed to a specific value to fit to the resolution of the desktop (higher/lower). '1' is the default value (100%).

Format: LightwareDeviceController -z <magnifying_value>

Example: LightwareDeviceController -z 1.2

ATTENTION: The last set value is stored and applied when LDC is started without a parameter.

6.3. Establishing the Connection

Step 1. Connect the device to a computer via Ethernet.

Step 2. Run the controller software; device discovery window appears automatically.

Changing the IP Address

To modify IP address settings quickly, it is not necessary to enter the device's settings/network menu, you can set them by clicking on the pencil icon next to the IP address.

You can see the new settings only in this window.

`#network #ipaddress #dhcp #mac`

This will change the IP address settings of the selected device remotely.

DHCP Fix IP

Serial number: 00004148

IP Address: 192.168.0.100

Network mask:

Default gateway:

Identifying the Device

Clicking on the icon makes the four front panel LEDs blink in green for 10 seconds. The feature helps to identify the device itself in the rack shelf. `#identifyme`

Import/Export the List of Favorite Devices

DIFFERENCE: This feature is available only from LDC version v2.5.5.

The list of favorite devices can be exported/imported using the dedicated buttons (saved as *.JSON file). The list can be imported later (in another computer, too), but please note that the current list will be overwritten by the imported list.

Device Discovery Window

Select the device in the Device discovery window and click on the green **Connect** button.

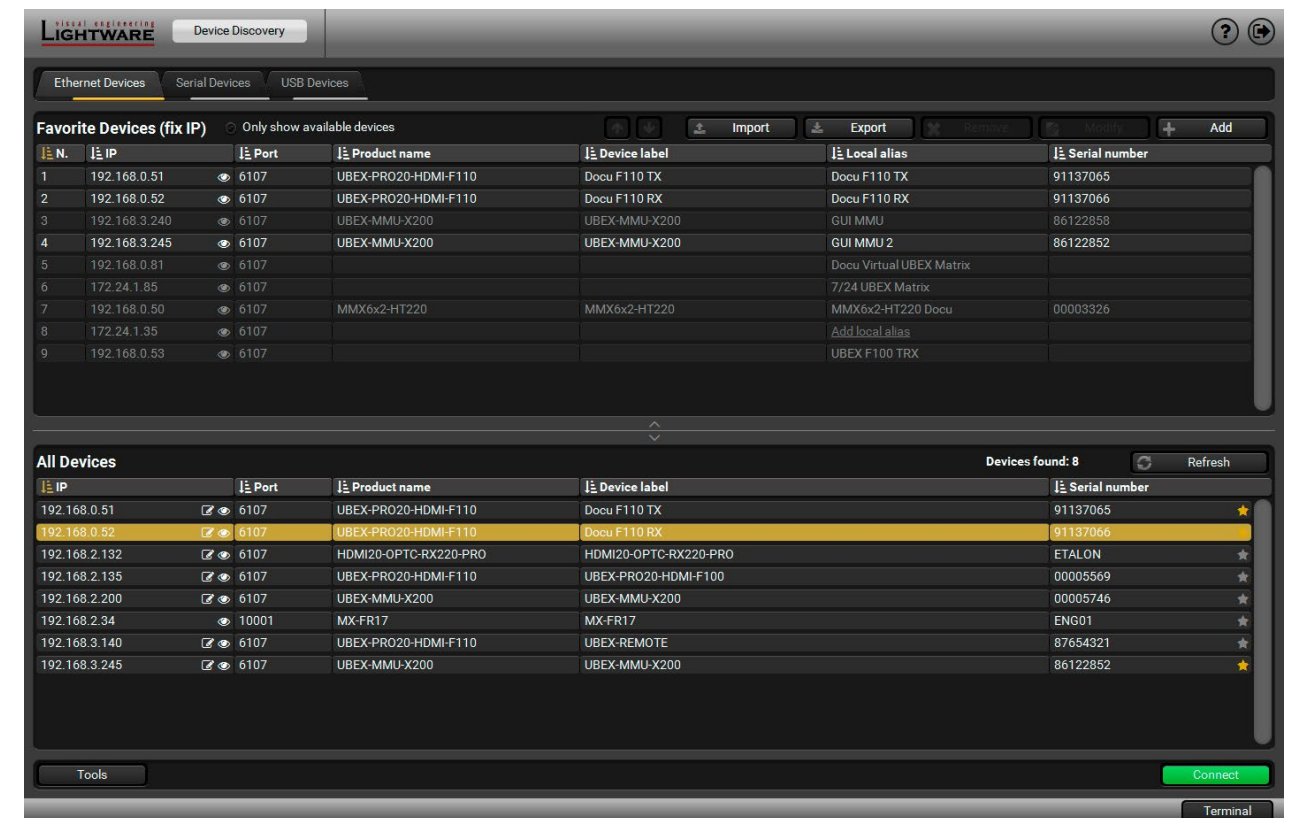

N.	IP	Port	Product name	Device label	Local alias	Serial number
1	192.168.0.51	6107	UBEX-PRO20-HDMI-F110	Docu F110 TX	Docu F110 TX	91137065
2	192.168.0.52	6107	UBEX-PRO20-HDMI-F110	Docu F110 RX	Docu F110 RX	91137066
3	192.168.3.240	6107	UBEX-MMU-X200	UBEX-MMU-X200	GUI MMU	86122858
4	192.168.3.245	6107	UBEX-MMU-X200	UBEX-MMU-X200	GUI MMU 2	86122852
5	192.168.0.81	6107			Docu Virtual UBEX Matrix	
6	172.24.1.85	6107			7/24 UBEX Matrix	
7	192.168.0.50	6107	MMX6x2-HT220	MMX6x2-HT220	MMX6x2-HT220 Docu	00003326
8	172.24.1.35	6107			Add local alias	
9	192.168.0.53	6107			UBEX F100 TRX	

IP	Port	Product name	Device label	Serial number
192.168.0.51	6107	UBEX-PRO20-HDMI-F110	Docu F110 TX	91137065
192.168.0.52	6107	UBEX-PRO20-HDMI-F110	Docu F110 RX	91137066
192.168.2.132	6107	HDMI20-OPTC-RX220-PRO	HDMI20-OPTC-RX220-PRO	ETALON
192.168.2.135	6107	UBEX-PRO20-HDMI-F110	UBEX-PRO20-HDMI-F100	00005569
192.168.2.200	6107	UBEX-MMU-X200	UBEX-MMU-X200	00005746
192.168.2.34	10001	MX-FR17	MX-FR17	ENG01
192.168.3.140	6107	UBEX-PRO20-HDMI-F110	UBEX-REMOTE	87654321
192.168.3.245	6107	UBEX-MMU-X200	UBEX-MMU-X200	86122852

Device discovery window in LDC

Favorite Devices (fix IP)

By clicking on the grey star icon next to the discovered devices, the most used units can be saved to the Favorite devices.

ATTENTION: Only the devices set with static (fix) IP address can be saved as favorite device.

Once the device is set as favorite, the star icon will be highlighted with yellow and the device will be displayed between the Favorite Devices (fix IP) window section.

6.4. Video Crosspoint Menu

6.4.1. Transmitter-Receiver Pair

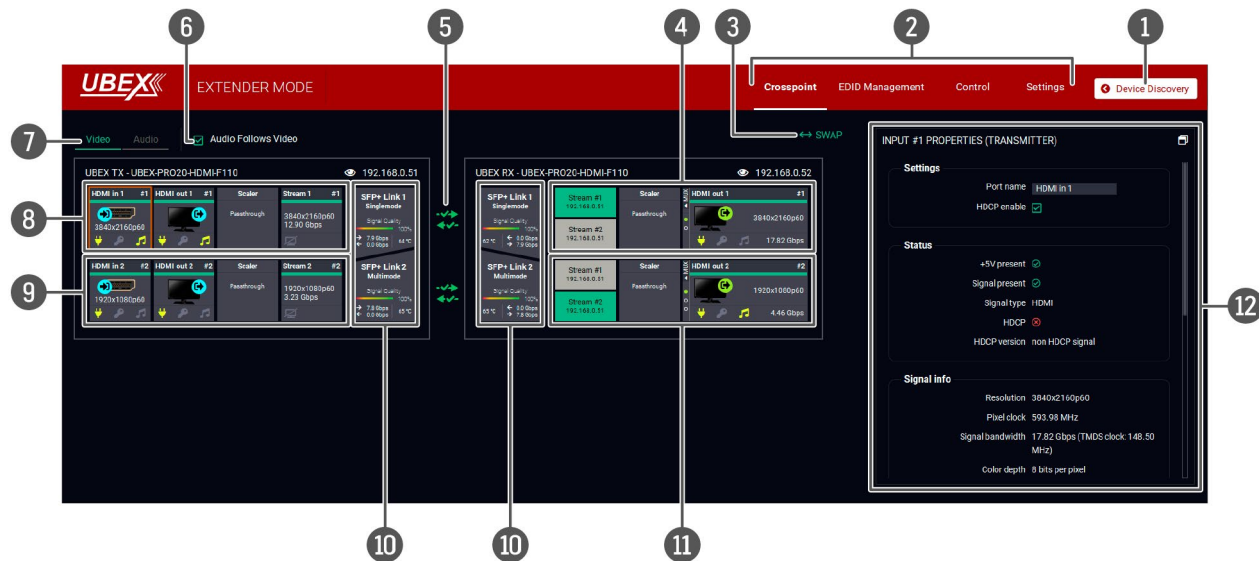

The Concept

The Crosspoint menu displays the UBEX **Transmitter** (left side) and the **Receiver** (in the middle) connected to each other. Clicking on a port or feature panel, the **Properties** of the selected item appears on the right side.

Legend of the Video Crosspoint Menu

- 1 **Device Discovery** Clicking on the button results in returning to the Device Discovery window. The connection with the current device will be terminated.
- 2 **Main menu** The available menu items (**Crosspoint**, **EDID Management**, **Control**, and **Settings**) are displayed. The **Terminal windows** are available under the Settings menu.
- 3 **Swap button** By clicking on the button, the orientation of the endpoint devices can be swapped. The feature effects the GUI view only.
- 4 **RX - HDMI out 1 port** Section of the HDMI out 1 port of the UBEX receiver. Available panels:
 - **Stream switcher**: select the source signal for the output port; Stream #1 is the signal of the HDMI in 1 port, Stream #2 is the signal of the HDMI in 2 port of the transmitter. See the tile legend in the [Stream Switcher / Stream Tiles](#) section.
 - **Scaler**: settings of the scaler for the output port. See the details in the [Scaler Panel - Output Side \(RX/TRX Modes\)](#) section.
 - **HDMI out 1**: the port properties of the HDMI out 1 port. See the details in the [Local HDMI Input Ports \(RX Mode\)](#) and the [Source MUX Selector](#) sections.

- 5 **Link aggregation status indicator** Indicates the current status of the SFP+ links. See the details about the icons in the [Link Aggregation Status Indicator](#) section.
- 6 **Audio follows video switcher**
 - **Enabled**: the audio stream follows the video stream when the video crosspoint is changed. Aside from this the audio streams can be switched separately from the video streams on the Audio crosspoint tab.
 - **Disabled**: switching of a video stream does not affect the audio crosspoint state.
- 7 **Layer tabs** The **video** and the **audio** crosspoint panel can be selected on the tabs.
- 8 **TX - HDMI in 1 and local HDMI out 1 ports** Section of the HDMI in 1 / out 1 ports of the UBEX transmitter. Available panels:
 - **HDMI in 1**: the port properties of the HDMI in 1 port. See the details in the [HDMI Input Ports \(TX/TRX Modes\)](#) section.
 - **HDMI out 1**: the port properties of the local HDMI out 1 port. See the details in the [Local HDMI Output Ports \(TX/TRX Modes\)](#) section.
 - **Scaler**: settings of the scaler for the output port. See the details in the [Scaler Panel - Input Side \(TX/TRX Modes\)](#) section.
 - **Stream 1**: the properties of the Stream #1. See the details in the [Stream Properties Panels \(TX/TRX Modes\)](#) section.
- 9 **TX - HDMI in 2 and local HDMI out 2 ports** Section of the HDMI in 2 / out 2 ports of the UBEX transmitter. Available panels:
 - **HDMI in 2**: the port properties of the HDMI in 2 port. See the details in the [HDMI Input Ports \(TX/TRX Modes\)](#) section.
 - **HDMI out 2**: the port properties of the local HDMI out 2 port. See the details in the [Local HDMI Output Ports \(TX/TRX Modes\)](#) section.
 - **Scaler**: settings of the scaler for the output port. See the details in the [Scaler Panel - Input Side \(TX/TRX Modes\)](#) section.
 - **Stream 2**: the properties of the Stream #2. See the details in the [Stream Properties Panels \(TX/TRX Modes\)](#) section.
- 10 **SFP+ ports** Status information and parameters of the SFP+ Link 1 and 2.
- 11 **RX - HDMI out 2 port** Section of the HDMI out 2 port of the UBEX receiver. Available panels:
 - **Stream switcher**: select the source signal for the output port; Stream #1 is the signal of the HDMI in 1 port, Stream #2 is the signal of the HDMI in 2 port of the transmitter. See the tile legend in the [Stream Switcher / Stream Tiles](#) section.
 - **Scaler**: settings of the scaler for the output port. See the details in the [Scaler Panel - Output Side \(RX/TRX Modes\)](#) section.
 - **HDMI out 2**: the port properties of the HDMI out 2 port. See the details in the [Local HDMI Input Ports \(RX Mode\)](#) and [Source MUX Selector](#) sections.
- 12 **Properties window** Settings and status information of the selected panel are displayed in this section. Clicking on the  icon, the properties section opens in a new window.

6.4.2. Transceiver-Transceiver Pair

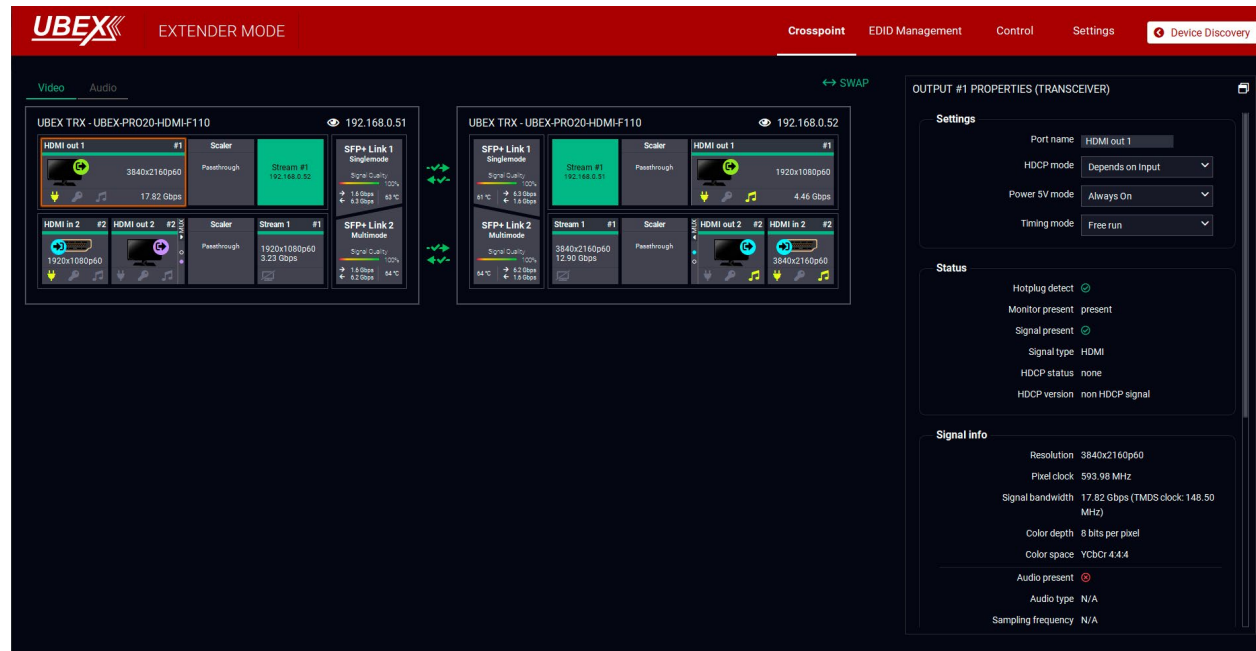

Video crosspoint menu - TRX-TRX pair in Extender mode

The Concept

The concept of the crosspoint menu in the case of a transceiver-transceiver pair is similar to that of the transmitter-receiver pair. The GUI displays the UBEX **Transceiver #1** (left side) and the **Transceiver #2** (in the middle) connected to each other. Clicking on a port or feature panel, the **Properties** of the selected item appears on the right side.

Streams

Each transceiver transmits one HDMI signal (up to 4K60 4:4:4 30 bit) to the remote device and receives one HDMI signal (up to 4K60 4:4:4 30 bit) from the remote device. The name of both streams are Stream #1, but the Stream tile displays the IP address of the source device for the easier identification.

See the legend of the tiles in the [Stream Switcher / Stream Tiles](#) section.

INFO: Thanks to the 20G full-duplex SFP+ interface, the transceiver has no bandwidth limitation on the input and output sides either. The device is able to receive and transmit 2x 4K60 Hz 4:4:4 24bit streams on both HDMI ports.

Properties Windows

The details of the properties, available settings, and status information of the selected panels are available in the [Properties Windows - Video Layer](#) section.

Clicking on the icon, the properties section opens in a new window.

6.4.3. Port Tiles

The port tiles and the colors of the displayed icons represent different states and information.

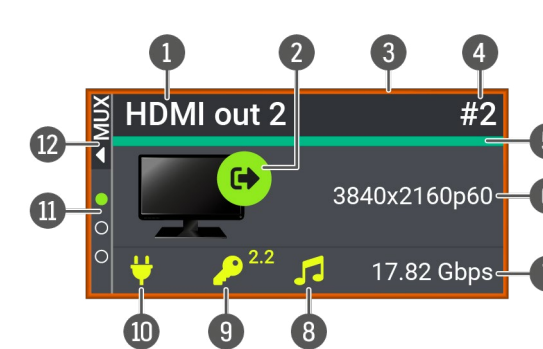

1 **Port name**

2 **Input / output port type indicator**

HDMI input port

Local HDMI output port

HDMI output port (the signal source is one of the input streams)

HDMI output port (the signal source is the copy of the HDMI out 1)

Analog audio input port

Analog audio output port

3 **Selected port indicator**

If the frame is orange, the properties panel of the port is displayed.

4 **Port ID**

5 **Signal present indicator**

If turquoise, signal is present, if grey, signal is not present.

6 **Resolution / refresh rate of the stream**

7 **Bandwidth of the stream**

8 **Embedded audio presence**

Embedded audio is present.

Embedded audio is not present.

9 **HDCP state**

2.2 The signal is encrypted with HDCP 2.2.

1.4 The signal is encrypted with HDCP 1.4.

The sink device is not compatible with the current HDCP version.

Signal is not HDCP-encrypted.

10 **+5V / Hotplug state**

Source/sink is connected.

Source/sink is not connected.

11 **Source multiplexer (MUX) selector**

The selected source is the Stream (coming from the SFP+ ports).

The selected source is the local HDMI input port.

The selected source is the copy of the HDMI out 1 port.

Selectable source signal

12 **Source multiplexer (MUX) expandable menu**

Clicking here opens the MUX menu with the selectable source signals of the output port. See more details about this function in the [Source MUX Selector](#) section.

6.5. Properties Windows - Video Layer

6.5.1. HDMI Input Ports (TX/TRX Modes)

Clicking on the HDMI input 1 or 2 port icon opens the Port properties. The most important signal information and settings are available on the panel: `#hdcp`

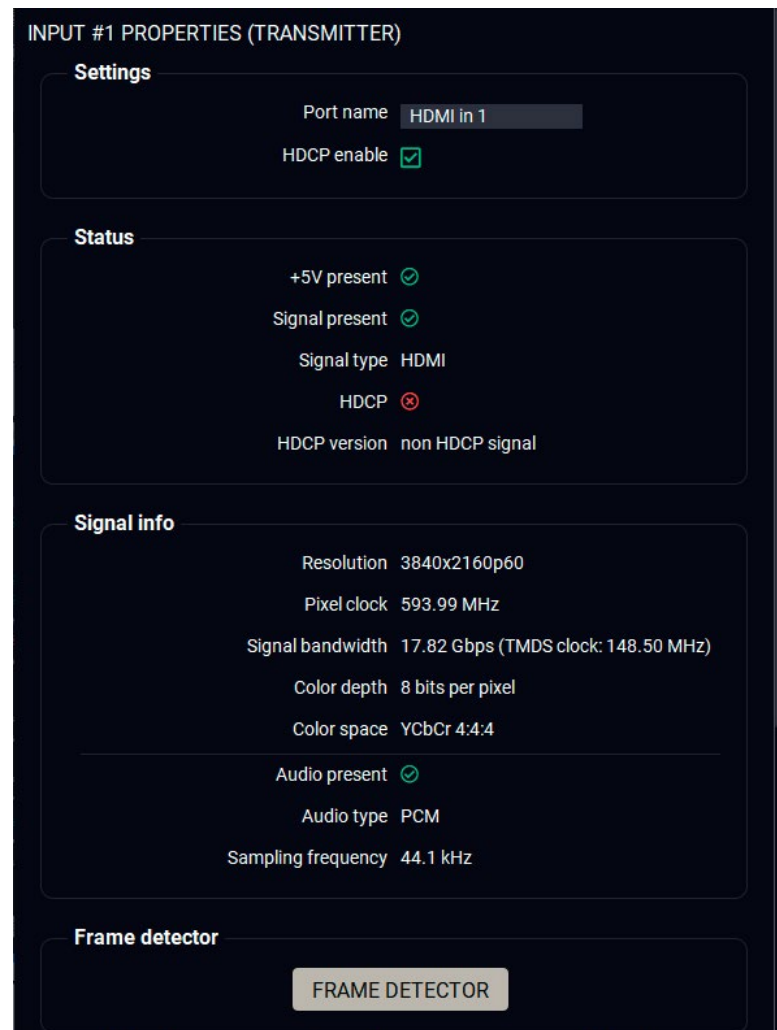

Port properties window of the HDMI in 1 (TX)

Available settings and tools:

- Port naming;
- **HDCP setting** (Enable / Disable);
- [Frame Detector](#);
- **Reloading factory default settings** for the selected port.

6.5.2. Local HDMI Output Ports (TX/TRX Modes)

Clicking on the HDMI output 1 or 2 port icon results in opening the Port properties. The most important signal and display information and settings are available on the panel: `#hdcp #power5v`

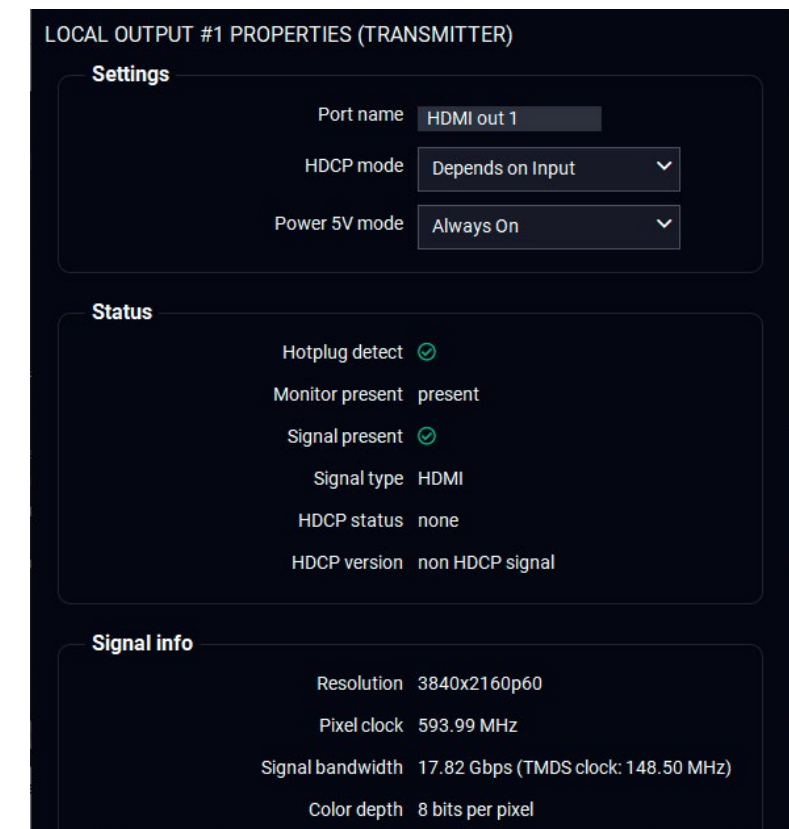

Port properties window of the HDMI out 1 (TX)

Available settings and tools:

- Port naming;
- **HDCP mode:**
 - Depends on input: the level and version of HDCP-encryption depends on the source device;
 - Maximum possible: the output ports set the maximum HDCP-encryption level that can be accepted by the connected sink device.
 - Forced HDCP 2.2 Type 1: the output ports always force HDCP 2.2 Type 1. If the sink device supports this HDCP-encryption level, the signal will be encrypted with HDCP 2.2 Type 0/1. **The signal will be encrypted with HDCP 2.2 Type 1 when the source and the sink both support this HDCP-encryption level.**
- **Power 5V mode** (Auto / Always on / Always off);
- [Frame Detector](#);
- **Reloading factory default settings** for the selected port.

6.5.3. Scaler Panel - Input Side (TX/TRX Modes)

Clicking on the Scaler panel on the HDMI input 1 of the transmitter or HDMI input 2 of the transceiver opens the Scaler properties. This feature allows the rescaling of the incoming stream to a different resolution and refresh rate to fit the sink device. `#scaler #frc #csc #colorspace #colorrange #colordepth`

DIFFERENCE: The transceiver is built with scaler function on HDMI input 2 port **from firmware version v2.1.0**. The Image position setting on this port is a read-only parameter and fixed as *Center* in case of previous firmware versions.

DIFFERENCE: The transmitter is built with scaler function on both HDMI input ports **from firmware version v2.4.1**. The Image position setting on the HDMI in 2 port is a read-only parameter and fixed as *Center* in case of previous firmware versions.

The most important signal and display information and settings are available on the panel.

The screenshot shows the 'INPUT #1 SCALER PROPERTIES (TRANSMITTER)' panel. It is divided into three main sections:

- Scaler settings:** Contains three dropdown menus: 'Scaling mode' set to 'Passthrough', 'Forced resolution' set to '1920x1080p60', and 'Image position' set to 'Fit'.
- Other video settings:** Contains three dropdown menus: 'Color space conversion' set to 'No conversion', 'Color range' set to 'No conversion', and 'Color depth setting' set to 'Pass'. Below these is a 'No sync screen' checkbox and a 'CONFIGURE' button.
- Other:** Contains two buttons: 'IDENTIFY STREAM' and 'FACTORY DEFAULTS'.

Scaler panel for the HDMI in 1 (TX)

Available settings and tools:

- **Scaling mode**
 - Passthrough: the scaler is in pass-through mode.
 - Forced resolution: the scaling is active, the selected value in the forced resolution option will be applied to the video signal;
- **Forced resolution:** list of the available resolutions with refresh rate values. The selected one will be applied to the video signal. See the available resolutions in the [Resolutions of the Scaler](#) section.
- **Image position** (Stretch / Fit / Center)
- **Color space conversion** (No conversion / RGB / YCbCr 4:4:4 / YCbCr 4:2:2);
- **Color range** (No conversion / Full range / Limited range);
- **Color depth setting** (Pass / 8bpc / 10 bpc / 12 bpc)
- **No Sync Screen (Test Pattern)** settings;
- **Identify Stream / Identify Display** button;
- **Reloading factory default settings** for the selected port.

6.5.4. Stream Properties Panels (TX/TRX Modes)

Clicking on the Stream 1 or Stream 2 panels on the transmitter/transceiver opens the properties of the video input streams. The most important signal information and settings are available on the panel. `#streamenable`

Stream 1 properties panel (TX)

Available settings and tools:

- Stream naming;
- Stream enable:** when it is checked in, the stream is transmitted to the receiver; if it is not, the stream is muted.
- [Identify Stream / Identify Display](#) button;
- [Frame Detector](#);
- Reloading factory default settings** for the selected port.

6.5.5. Stream Switcher / Stream Tiles

The incoming streams from the transmitter can be routed to the HDMI output 1 and/or 2 ports of the receiver. `#switch #crosspoint`

Legend of the Stream Tiles

Tile	Selected	Signal present	Stream enabled	SFP+ link bandwidth
Stream #1 192.168.0.101	✘	✘	N/A	N/A
Signal is not present and stream is not selected.				
Stream #1 192.168.0.101	✔	✘	N/A	N/A
Signal is not present but stream is selected.				
Stream #1 192.168.0.101	✘	N/A	✘	N/A
The stream is disabled and not selected.				
Stream #1 192.168.0.101	✔	N/A	✘	N/A
The stream is disabled but selected.				
Stream #1 192.168.0.101	✘	✔	✔	✘
Signal is present, stream is enabled, but bandwidth is not enough for the transmission.				
Stream #1 192.168.0.101	✔	✔	✔	✔
Signal is present, stream is selected, and the bandwidth is OK.				

INFO: The maximum available bandwidth with the endpoint device is 20 Gbps, which requires 2x 10 GbE SFP+ module or DAC cable to install. If one 10 GbE SFP+ module is installed only but the signal is 4K@60 Hz (which requires ~14 Gbps to transmit), the stream tile will be yellow.

INFO: When the signal bandwidth limit is exceeded, the stream of the HDMI in 1 on the TX side and the stream of the HDMI out 1 on the RX side will be enabled at the expense of the HDMI in 2 / HDMI out 2. See more information in the [Bandwidth Limitation](#) section.

INFO: You can find the bandwidth requirements of each resolution in the [Bandwidth Requirements of the Resolutions](#) section.

6.5.6. Scaler Panel - Output Side (RX/TRX Modes)

Clicking on the Scaler panel on the HDMI output 1 and 2 of the receiver and on the HDMI output 1 of the transceiver opens the Scaler properties. This feature allows the rescaling of the incoming stream to different resolution and refresh rate to fit the sink device. `#scaler #frc #csc #colorspace #colorrange #colordepth`

DIFFERENCE: The receiver is built with scaler function on both HDMI output ports **from firmware version v2.1.0**.

The most important signal and display information and settings are available on the panel.

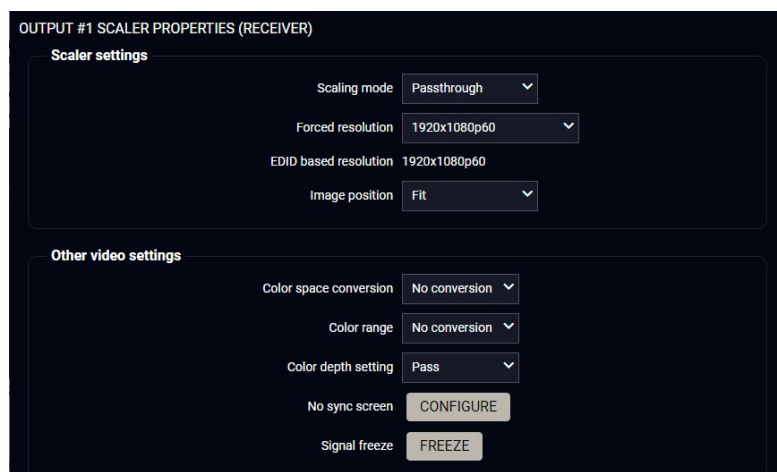

Scaler panel for the HDMI out 1 (RX)

Available settings and tools:

- **Scaling mode**
 - Passthrough: the scaler is in pass-through mode.
 - Forced resolution: the scaling is active, the selected value in the forced resolution option will be applied to the video signal;
 - EDID based: the scaler forces the resolution that is read out from the EDID of the connected sink device.
- **Forced resolution:** list of the available resolutions with refresh rate values. The selected one will be applied to the video signal. See the available resolutions in the [Resolutions of the Scaler](#) section.
- **Image position** (Stretch / Fit / Center)
- **Color space conversion** (No conversion / RGB / YCbCr 4:4:4 / YCbCr 4:2:2);
- **Color range** (No conversion / Full range / Limited range);
- **Color depth setting** (Pass / 8 bpc / 10 bpc / 12 bpc)
- **No Sync Screen (Test Pattern)** settings;
- **Signal freeze button:** the signal freezes at the last video frame on the sink device (the sink may show a broken frame too). `#freeze`
- **Reloading factory default settings** for the selected port.

6.5.7. Local HDMI Input Ports (RX Mode)

Clicking on the HDMI input 1 or 2 port icon results in opening the Port properties. The most important signal and display information and settings are available on the panel: `#hdcp`

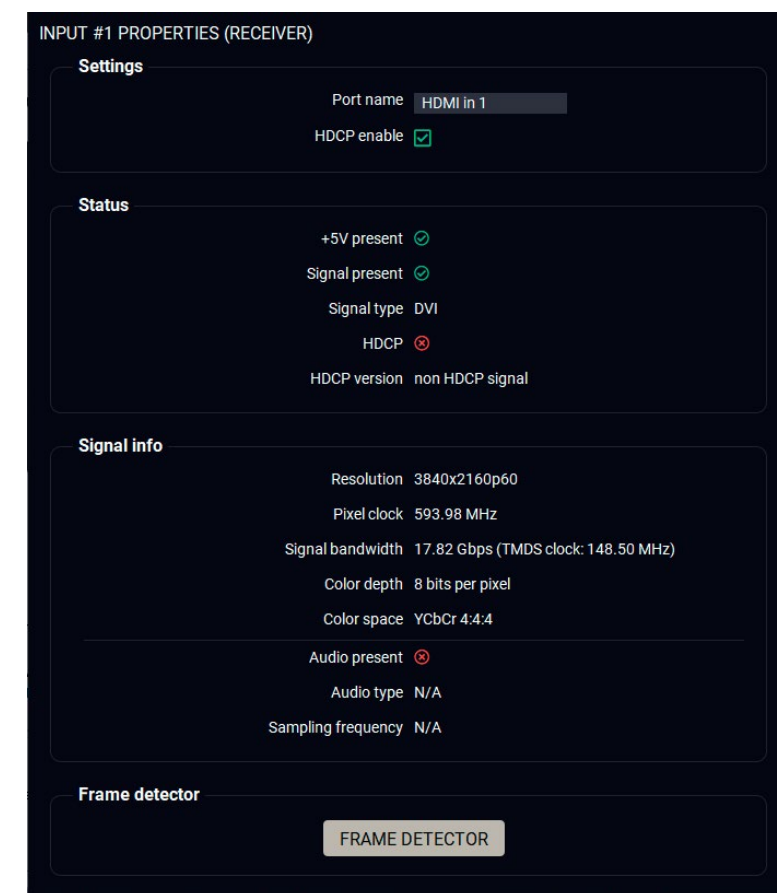

Port properties window of the HDMI in 1 (RX)

Available settings and tools:

- Port naming;
- **HDCP setting** (Enable / Disable);
- **Frame Detector**;
- **Reloading factory default settings** for the selected port.

6.5.8. HDMI Output Ports (RX/TRX Modes)

Clicking on the HDMI output 1 or 2 port icon opens the Port properties. The most important signal and display information and settings are available on the panel: `#hdcv` `#power5v` `#timingmode` `#freerun` `#sourcelocked`

Available settings and tools:

- Port naming;
- **HDCP mode:**
 - Depends on input: the level and version of HDCP-encryption depends on the source device;
 - Maximum possible: the output ports set the maximum HDCP-encryption level that can be accepted by the connected sink device.
 - Forced HDCP 2.2 Type 1: the output ports always force HDCP 2.2 Type 1. If the sink device supports this HDCP-encryption level, the signal will be encrypted with HDCP 2.2 Type 0/1. **The signal will be encrypted with HDCP 2.2 Type 1 when the source and the sink both support this HDCP-encryption level.**
- **Power 5V mode** (Auto / Always on / Always off);
- **Timing mode** (Free run / Source locked).

ATTENTION: When the Source locked mode setting was unsuccessful and the port uses Free run mode as fallback, an  icon appears beside the settings. It may be caused by that the scaler / FRC setting is not in Pass-through mode or the resolution of the source stream is not the same as the destination stream's one.

- [Frame Detector](#);
- [Identify Stream / Identify Display](#) button;
- **Reloading factory default settings** for the selected port.

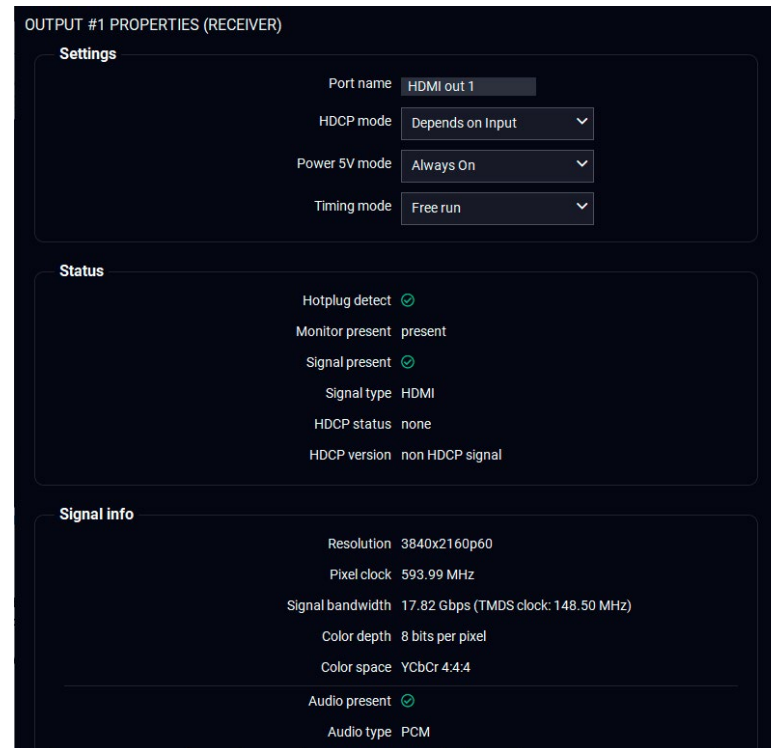

6.5.9. SFP+ Link Panels (TX/RX/TRX Modes)

Clicking on the SFP+ Link 1 or 2 panel opens the properties of the SFP+ connections. The most important signal information and the parameters of the SFP+ transceiver module or DAC cable are available on the panel. `#sfp`

ATTENTION: If the  icon appears, that means incompatible optical transceiver module is installed to the endpoint device (SFP optical module (1 GbE) instead of SFP+ module (10 GbE)).

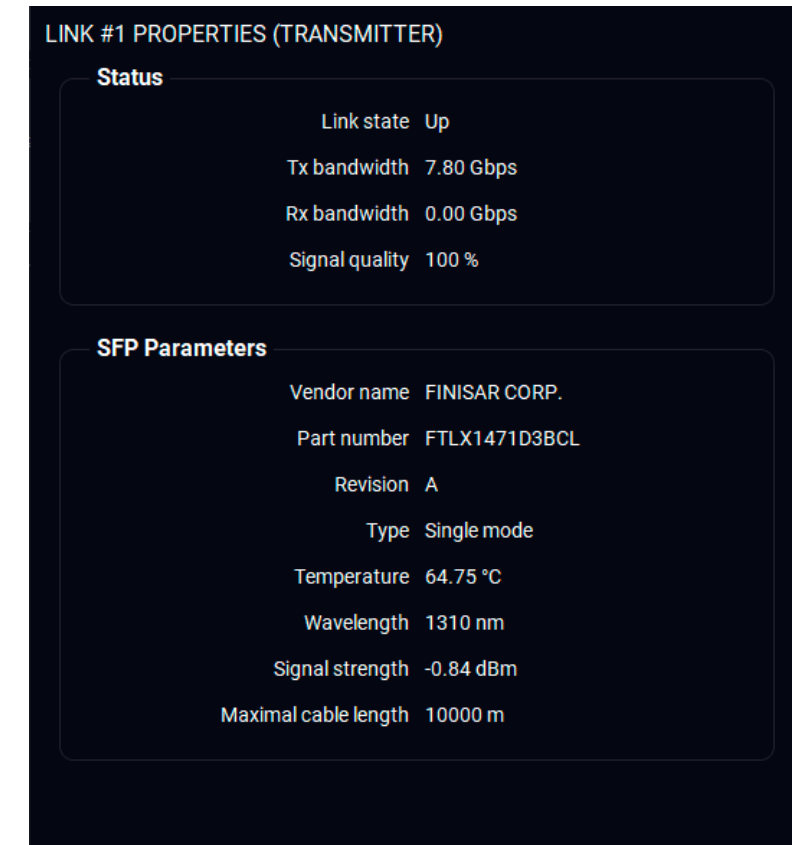

SFP+ Link 1 properties panel (TX)

6.5.10. Source MUX Selector

The source multiplexer (**Source MUX**) makes routing several different source signals to the HDMI output ports available. See more details about this function in the [Receiver Mode](#) and [Transceiver Mode](#) sections. `#mux` `#sourcemux`

Click on the MUX menu to expand the source MUX selector.

ATTENTION: The audio crosspoint settings always follow the source MUX settings of the video layer and the MUX settings cannot be set in the audio layer.

Receiver (RX) Mode

HDMI Out 1

- **Stream** - The signal source of the output port is the stream coming from the remote device.
- **HDMI in 1** - The signal source of the output port is the stream of the local input port of the receiver. The HDMI in 1 port panel will be available when selecting this option.



HDMI Out 2

- **Stream** - The signal source of the output port is the stream coming from the remote device.
- **HDMI in 2** - The signal source of the output port is the stream of the local input port of the receiver. The HDMI in 2 port panel will be available when selecting this option.
- **Copy** - The device is able to copy the signal of the HDMI out 1 port. This is the COPY function.



INFO: The Copy function is available only on the HDMI out 2 port.

TIPS AND TRICKS: The source of the output port can also be selected without expanding the MUX menu.

Transceiver (TRX) Mode

HDMI Out 2

- **HDMI in 2** - The signal source of the local output port is the stream of the input port of the transceiver.
- **Copy** - The device is able to copy the signal of the HDMI out 1 port. This is the COPY function.



TIPS AND TRICKS: The source of the output port can also be selected without expanding the MUX menu.

6.5.11. Identify Stream / Identify Display

Clicking on the Identify Stream / Identify Display button generates 10 test colors on the display device for 10 seconds. The feature helps to identify the stream and the screen itself physically. `#identifystream` `#identifydisplay`



The order of the test colors in the Identify stream feature

The feature is available on the following panels:

- [Scaler Panel - Input Side \(TX/TRX Modes\)](#)
- [Stream Properties Panels \(TX/TRX Modes\)](#)
- [Local HDMI Input Ports \(RX Mode\)](#)

6.5.12. Link Aggregation Status Indicator

Icon	Description
	SFP+ connection is established successfully and the link aggregation is working successfully.
	Waiting for the link aggregation.
	No connection is established between the SFP+ links.

INFO: You can find possible causes and solution suggestions in the [Troubleshooting](#) chapter in the case of no connection or link aggregation problems.

6.6. Audio Crosspoint Menu

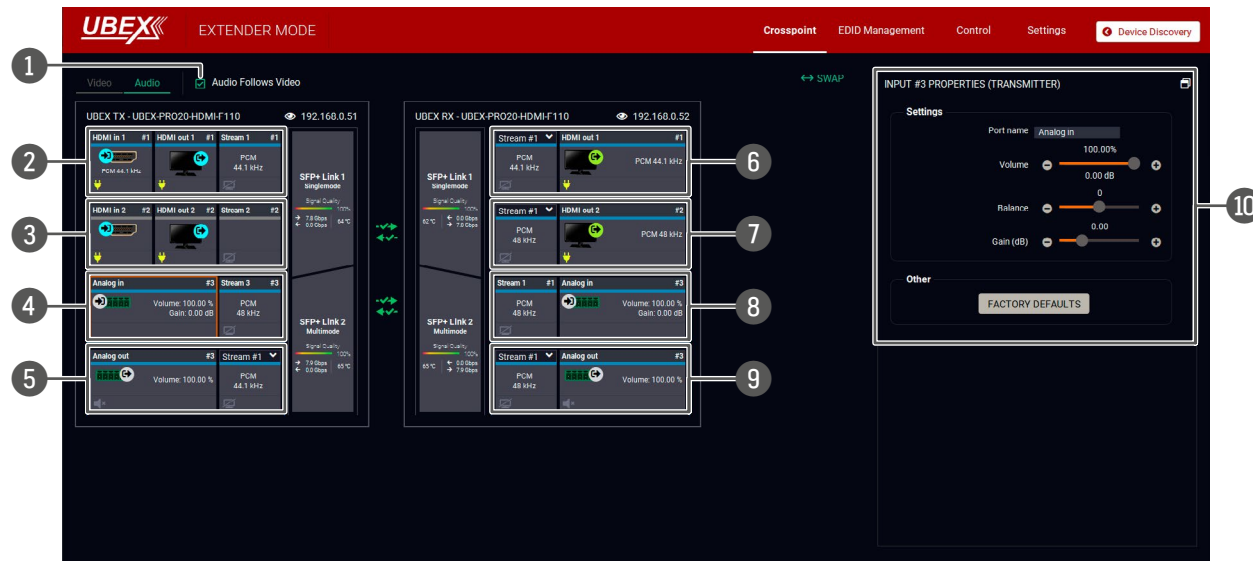

Crosspoint menu - Audio layer for Extender mode

The Concept

The Crosspoint menu displays the UBEX Transmitter (left side) and the Receiver (in the middle) connected to each other. By clicking on a port or feature panel, the **Properties** of the selected item appear on the right side. The selected port or feature panel is highlighted with orange. *#audio*

Legend of the Audio Crosspoint Menu

- 1 **Audio follows video switcher**
 - **Enabled:** the audio stream follows the video stream when the video crosspoint is changed. Aside from this, the audio streams can be switched separately from the video streams on the Audio crosspoint tab.
 - **Disabled:** switching of a video stream does not affect the audio crosspoint state.
- 2 **TX - HDMI in 1 and local HDMI out 1 ports**

Section of the HDMI in 1 / out 1 ports of the UBEX transmitter. Available panels:

 - **HDMI in 1:** the audio port properties of the HDMI in 1 port.
 - **HDMI out 1:** the port properties of the local HDMI out 1 port.
 - **Stream 1:** the properties of the Stream 1 of the transmitter.
- 3 **TX - HDMI in 2 and local HDMI out 2 ports**

Section of the HDMI in 2 / out 2 ports of the UBEX transmitter. Available panels:

 - **HDMI in 2:** the audio port properties of the HDMI in 2 port.
 - **HDMI out 2:** the port properties of the local HDMI out 2 port.
 - **Stream 2:** the properties of the Stream 2 of the transmitter.

- 4 **TX - Analog audio input port**

Section of the analog audio input port of the UBEX transmitter. Available panels:

 - **Analog in:** the port properties of the analog audio input port of the transmitter. See the details in the [Analog Audio Input Port](#) section.
 - **Stream 3:** the properties of the Stream 3 of the transmitter.
- 5 **TX - Analog audio output port**

Section of the analog audio output port of the UBEX transmitter. Available panels:

 - **Analog out:** the port properties of the analog audio output port of the transmitter. See the details in the [Analog Audio Output Port](#) section.
 - **Stream switcher:** select the source signal for the output port. See the details in the [Stream Switcher](#) section.
- 6 **RX - HDMI out 1 port**

Section of the HDMI out 1 port of the UBEX receiver. Available panels:

 - **Stream switcher:** select the source signal for the output port. See the details in the [Stream Switcher](#) section.
 - **HDMI out 1:** the port properties of the HDMI out 1 port.
- 7 **RX - HDMI out 2 port**

Section of the HDMI out 2 port of the UBEX receiver. Available panels:

 - **Stream switcher:** select the source signal for the output port. See the details in the [Stream Switcher](#) section.
 - **HDMI out 2:** the port properties of the HDMI out 2 port.
- 8 **RX - Analog audio output port**

Section of the analog audio output port of the UBEX receiver. Available panels:

 - **Stream switcher:** select the source signal for the output port. See the details in the [Stream Switcher](#) section.
 - **Analog out:** the port properties of the analog audio output port of the receiver. See the details in the [Analog Audio Output Port](#) section.
- 9 **RX - Analog audio input port**

Section of the analog audio input port of the UBEX receiver. Available panels:

 - **Stream 1:** the properties of the Stream 1 of the receiver.
 - **Analog in:** the port properties of the analog audio input port of the receiver. See the details in the [Analog Audio Input Port](#) section.
- 10 **Properties window**

The properties, available settings, and status information of the selected panel are displayed in this section. Clicking on the icon, the properties section opens in a new window.

DIFFERENCE: Only UBEX-PRO20-HDMI-F110, -F111, -F120, -F121 and F130 models are built with analog audio input and output ports.

DIFFERENCE: HBR audio formats are supported from LDC version **v2.5.8b2** and endpoint firmware version **v2.0.0** only. If the embedded audio signal is HBR and an **HBR audio not supported** error message is received during the new crosspoint setting, please update the control software to the latest one. See more information about the updating procedure in the [Install and Update](#) section.

ATTENTION: The audio crosspoint settings always follow the source MUX settings of the video layer and the MUX settings cannot be set in the audio layer.

6.7. Properties Windows - Audio Layer

6.7.1. Analog Audio Input Port

Clicking on the **Analog in** port icon of the transmitter, receiver, or transceiver opens the Port properties. The most important signal and display information and settings are available on the panel:

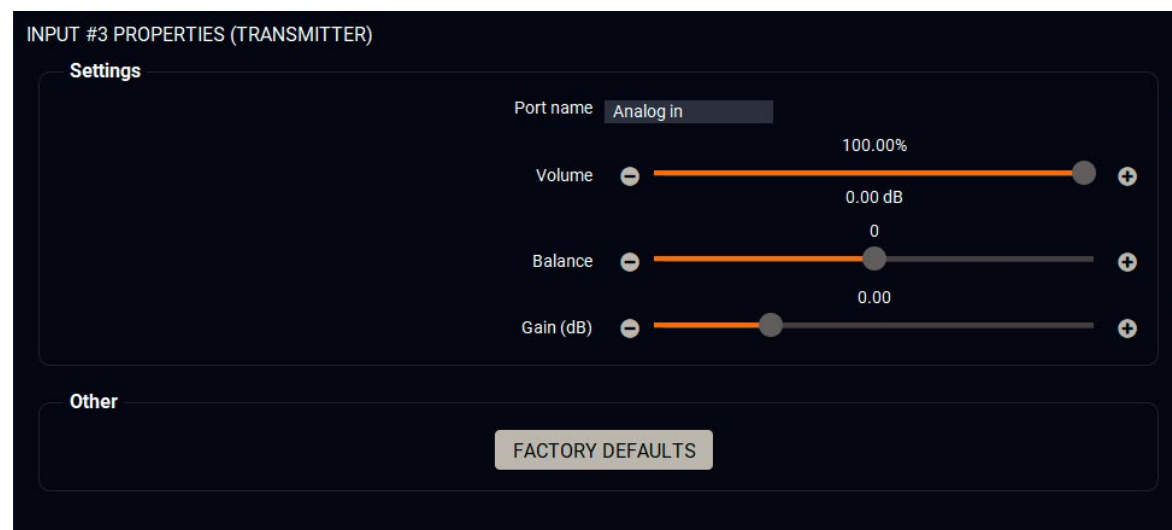

Port properties window of the Analog in (TX)

Available settings and tools:

- Port naming;
- **Volume:** sets the input volume (attenuation) between 0% (-95.62 dB) and 100% (0 dB). Clicking on the **−** icon results in -1%, the **+** icon results in +1% in the volume setting. The default value is 100%.
- **Balance:** sets the balance between -100 (total left) and 100 (total right). Clicking on the **−** icon results in -1, the **+** icon results in +1 in the balance setting. The default value is 0 (center).
- **Gain:** sets the gain between -12 dB and 35 dB. Clicking on the **−** icon results in -1 dB, the **+** icon results in +1 dB in the gain setting. The default value is 0 dB.
- **Reloading factory default settings** for the selected port.

#analogaudio #volume #balance #gain

6.7.2. Analog Audio Output Port

Clicking on the **Analog out** port icon of the transmitter, receiver, or transceiver opens the Port properties. The most important signal and display information and settings are available on the panel:

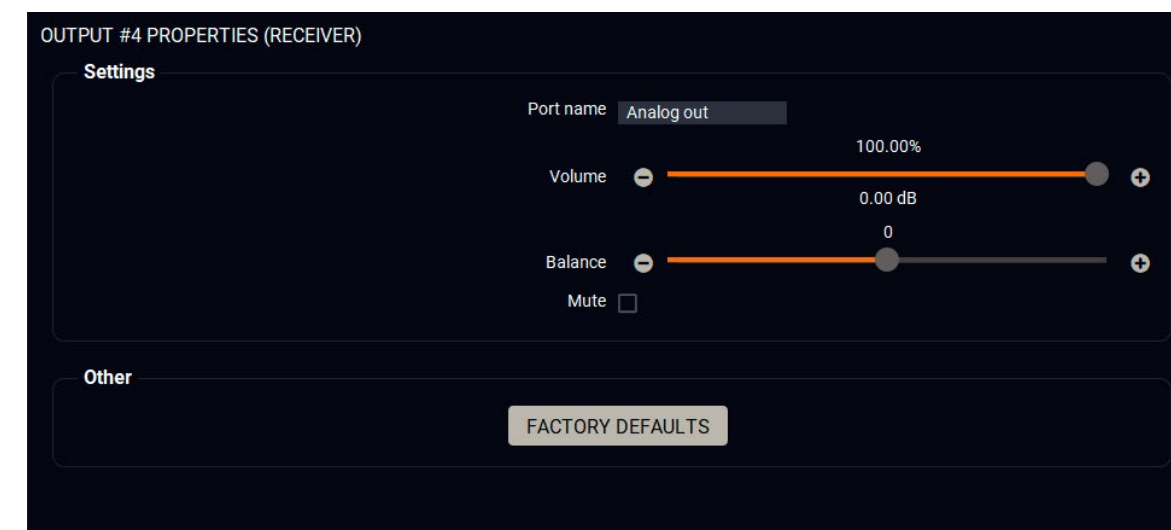

Port properties window of the Analog out (RX)

Available settings and tools:

- Port naming;
- **Volume:** sets the input volume (attenuation) between 0% (-95.62 dB) and 100% (0 dB). Clicking on the **−** icon results in -1%, the **+** icon results in +1% in the volume setting. The default value is 100%.
- **Balance:** sets the balance between -100 (total left) and 100 (total right). Clicking on the **−** icon results in -1, the **+** icon results in +1 in the balance setting. The default value is 0 (center).
- **Mute:** enable or disable the muting of the output port.
- **Reloading factory default settings** for the selected port.

6.7.3. Stream Switcher

Clicking on the drop-down menu of the output port (any HDMI and analog output ports), the source stream of the port can be selected.

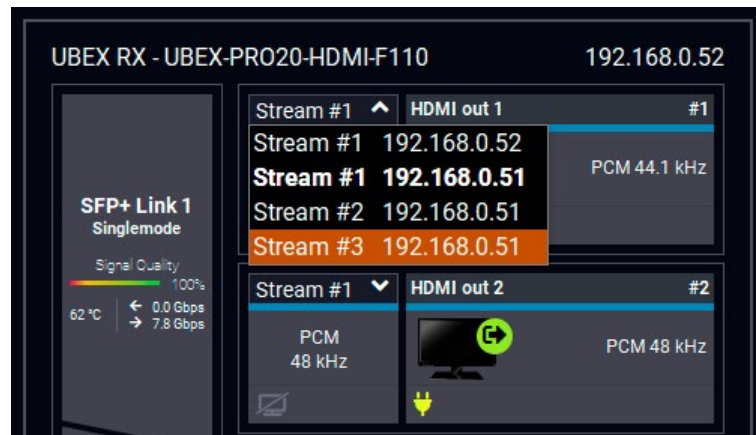

The stream switcher drop-down menu of the HDMI out 1 (RX)

Four source streams are available for all output ports. The highlighted one is the selected stream. The naming is the following: **Stream #1..3**; and the **IP address** of the source device. `#switch #crosspoint`

Streams - TX-RX Pair

The Stream #1 and #2 are always the digital audio stream of the HDMI in 1 and 2 ports of the transmitter. The Stream #3 is always the audio stream of the analog audio input port of the transmitter or the receiver.

Streams - TRX-TRX Pair

The Stream #1 is always the digital audio stream of the HDMI in 2 port of the transceiver, the Stream #2 is always the audio stream of the analog audio input port of the transceiver.

6.8. Diagnostic Tools

6.8.1. Frame Detector

The ports can show detailed information about the signal like blanking intervals and active video resolution. This feature can be used for troubleshooting if compatibility problems occur during system installation. To access this function, open the port properties window and click on the **Frame detector** button.

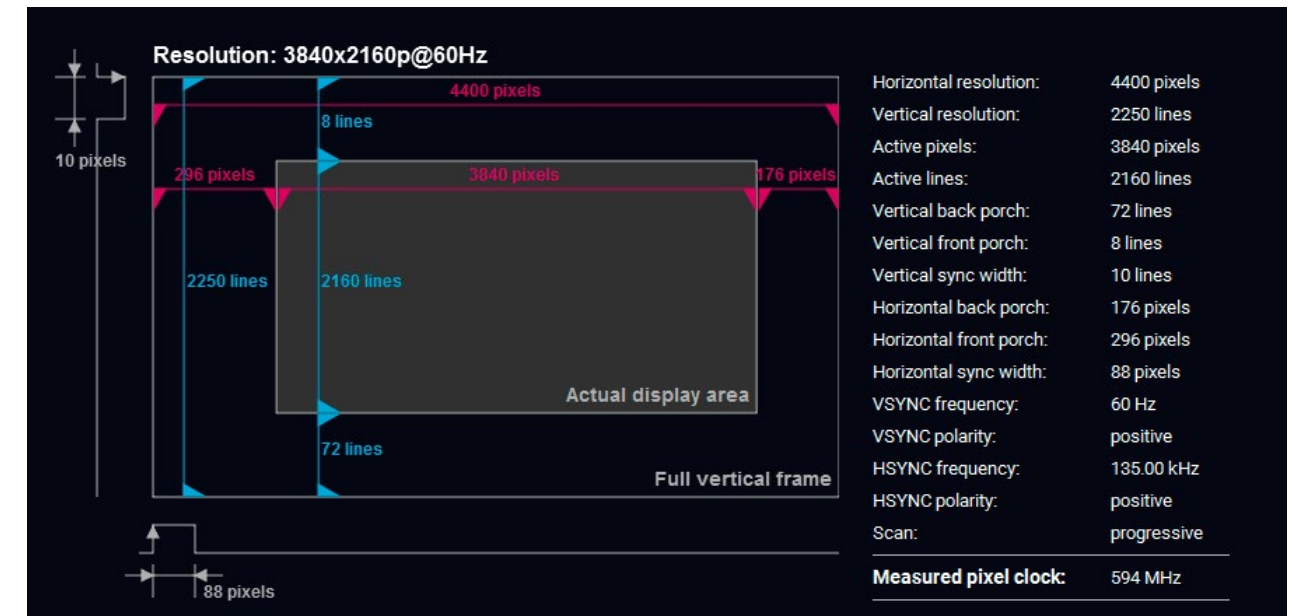

Frame detector window

Lightware's Frame Detector function works like a signal analyzer and allows to determine the exact video format that is present on the port, thus it helps to identify various problems. E.g. actual timing parameters may differ from the expected and this may cause some displays to drop the picture.

Frame Detector measures detailed timings of the video signals just like a built-in oscilloscope, but it is much easier to use. Actual display area shows the active video size (dark grey). The black area of the full frame is the blanking interval, which can contain the info frames and embedded audio data for HDMI signals. Shown values are measured on the actual signal and not retrieved only from the HDMI info frames.

`#framedetector`

6.8.2. No Sync Screen (Test Pattern)

The No sync screen feature generates an image that can be displayed when there is no incoming signal on the port. The following settings can be set for the Test Pattern function:
#testpattern #nosyncscreen

Mode

- **Always on:** the video output port always transmits the test pattern.
- **Auto:** the video output port transmits the test pattern if there is no incoming signal on the selected input port.
- **Always off:** the test pattern function is disabled, the video output port transmits the video signal of the selected input port.
- **Freeze:** the signal freezes at the last video frame on the sink device (the sink may show a broken frame too). #freeze

Color

Three ways are available to set the no sync screen color:

- Click on the predefined color;
- Use the sliders;
- Type the RGB code of the color.

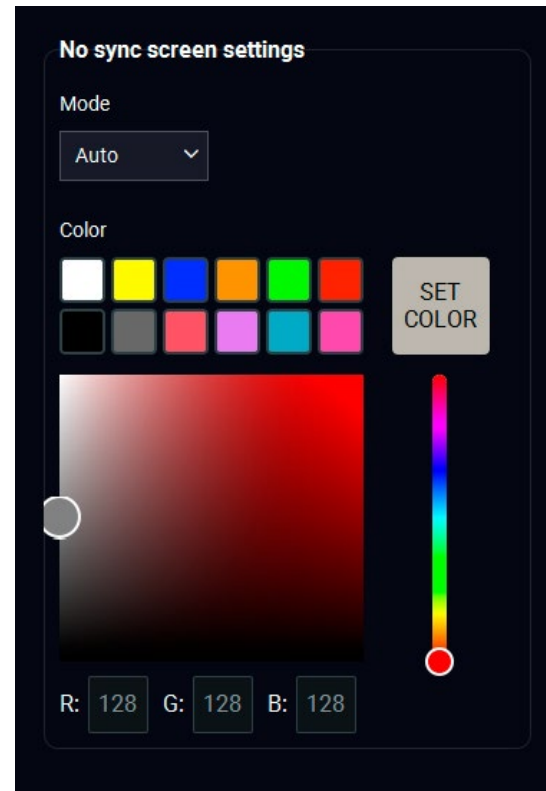

When the desired color is selected, press the **Set color** button to store.

Port Tile

The port tile of the HDMI outputs displays when No sync screen mode is active.

INFO: No sync screen will be active in the case of connected sink device to the output port only.

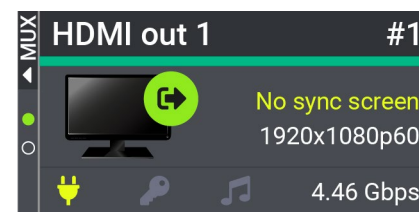

6.9. EDID Management Menu

Advanced EDID Management can be accessed by selecting the EDID Management menu. There are two panels: left one contains Source EDIDs, right one contains Destination places where the EDIDs can be emulated or copied. #edid

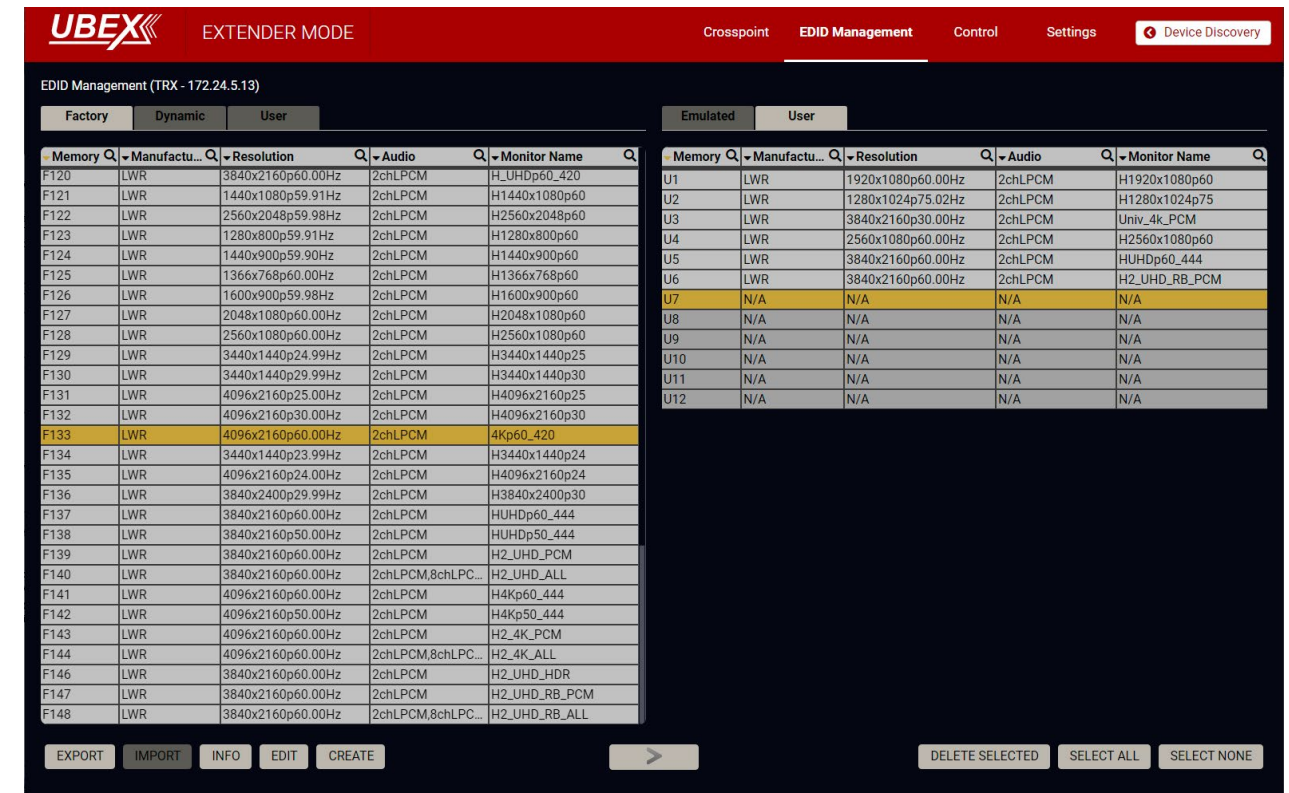

EDID Management menu

Control Buttons

EXPORT	Exporting an EDID (save to a file)	>	Transfer button: executing EDID emulation or copying
IMPORT	Importing an EDID (load from a file)	DELETE SELECTED	Deleting EDID (from User memory)
INFO	Display EDID Summary window	SELECT ALL	Selecting all memory places in the right panel
EDIT	Opening Advanced EDID Editor with the selected EDID	SELECT NONE	Selecting none of the memory places in the right panel
CREATE	Opening Easy EDID Creator		

6.9.1. EDID Operations

Changing Emulated EDID

- Step 1.** Choose the desired **EDID list** on the source panel and select an **EDID**.
- Step 2.** Press the **Emulated** button on the top of the Destination panel.
- Step 3.** Select the desired **port** on the right panel (one or more ports can be selected); the EDID(s) will be highlighted with a yellow cursor.
- Step 4.** Press the **Transfer** button to change the emulated EDID.



Learning an EDID

The process is the same as changing the emulated EDID; the only difference is the Destination panel: press the **User** button. Thus, one or more EDIDs can be copied into the user memory either from the factory memory or from a connected sink (Dynamic).

Exporting an EDID

- Source EDID can be downloaded as a file (*.bin, *.dat or *.edid) to the computer.
- Step 1.** Select the desired **EDID** from the Source panel (line will be highlighted with yellow).
 - Step 2.** Press the **Export** button to open the dialog box and save the file to the computer.

EXPORT

Importing an EDID

- Previously saved EDID (*.bin, *.dat or *.edid file) can be uploaded to the user memory:
- Step 1.** Press the **User** button on the top of the Source panel and select a **memory** slot.
 - Step 2.** Press the **Import** button below the Source panel.
 - Step 3.** Browse the file in the opening window, then press the **Open** button. Browsed EDID is imported into the selected User memory.

IMPORT

ATTENTION: The imported EDID overwrites the selected memory place even if it is not empty.

Deleting EDID(s)

- The EDID(s) from User memory can be deleted as follows:
- Step 1.** Press **User** button on the top of the Destination panel.
 - Step 2.** Select the desired **memory** slot(s); one or more can be selected (“Select All” and “Select None” buttons can be used). The EDID(s) will be highlighted with yellow.
 - Step 3.** Press the **Delete selected** button to delete the EDID(s).

DELETE SELECTED

6.9.2. Editing an EDID

Select an EDID from the Source panel and press the **Edit** button to display the Advanced EDID Editor window. The editor can read and write all descriptors that are defined in the standards, including the additional CEA extensions. Any EDID from the device's memory or a saved EDID file can be loaded into the editor. The software resolves the raw EDID and displays it as readable information to the user. All descriptors can be edited and saved in an EDID file, or uploaded to the User memory. For more details about EDID Editor, please visit our website (<https://go.lightware.com/edid-editor-application-notes>) and download the EDID Editor user manual.

EDIT

The screenshot shows the EDID Editor window. On the left, there is a list of descriptors to be edited:

- Basic EDID
 - Vendor / Product Information
 - Display Parameters
 - Power Management and Features
 - Gamma / Color and Established Timings
 - Standard Timings
 - Preferred Timing Mode
 - 2nd Descriptor Field
 - 3rd Descriptor Field
 - 4th Descriptor Field
- CEA Extension
 - General
 - Video Data
 - Audio Data
 - Speaker Allocation Data
 - HDMI
 - Colorimetry
 - Detailed Timing Descriptor #1
 - Detailed Timing Descriptor #2
 - Detailed Timing Descriptor #3
 - Detailed Timing Descriptor #4
 - Detailed Timing Descriptor #5
 - Detailed Timing Descriptor #6
- Save EDID

On the right, the EDID Byte Editor displays a hex grid of the EDID data:

	0	1	2	3	4	5	6	7	8	9
0	00	FF	FF	FF	FF	FF	FF	00	4C	2D
10	8E	09	00	00	00	00	09	16	01	03
20	80	34	1D	78	0A	7D	D1	A4	56	50
30	A1	28	0F	50	54	BD	EF	80	71	4F
40	81	C0	81	00	81	80	95	00	A9	C0
50	B3	00	01	01	02	3A	80	18	71	38
60	2D	40	58	2C	45	00	09	25	21	00
70	00	1E	66	21	56	AA	51	00	1E	30
80	46	8F	33	00	09	25	21	00	00	1E
90	00	00	00	FD	00	18	4B	1A	51	17
100	00	0A	20	20	20	20	20	20	00	00
110	00	FC	00	54	32	34	42	33	30	31
120	0A	20	20	20	20	20	01	6C		

EDID Editor window

6.9.3. Creating an EDID - Easy EDID Creator

Since the above mentioned Advanced EDID Editor needs more detailed knowledge about EDID, Lightware introduced a wizard-like interface for fast and easy EDID creation. With Easy EDID Creator it is possible to create custom EDIDs in four simple steps. By clicking on the **Create** button below the Source panel, **Easy EDID Creator** is opened in a new window.

CREATE

Select Resolution & Interface

Welcome to the Easy EDID Creator!

With this software you are able to create a unique EDID according to your demands. Details can be added or changed in the Advanced EDID Editor later if needed.

Please select the format type and the preferred resolution. If you don't find the proper mode in the list, use the Custom format type setting, enter the resolution and the program will estimate the best blanking times.

Important notes:

- If you want to send audio then you must select HDMI or DisplayPort. DVI and VGA do not support audio transmission.
- Most DVI displays are not able to process HDMI signals. If you have a DVI display, please check its specifications.
- The supported color depth will be 24bits/pixel by default.

Format type:

Resolution:

Interface type:

EDID Creator window

6.9.4. EDID Summary Window

Select an EDID from Source panel and press the **Info** button to display EDID summary.

INFO

General

EDID version: 1

EDID revision: 3

Manufacturer ID: SAM (Samsung Electric Company)

Product ID: 8E09

Monitor serial number: Not present

Year of manufacture: 2012

Week of manufacture: 9

Signal interface: Digital

Separate Sync H&V: -

Composite sync on H: -

Sync on green: -

Serration on VS: -

Color depth: Undefined

Interface standard: Not defined

Color spaces: RGB 4:4:4 & YCrCb 4:4:4

Aspect ratio: 0.56

Display size: 52 cm X 29 cm

EDID summary window

6.10. Control Menu

The Ethernet control ports, the RS-232 port and the Infrared input/output ports can be configured in the Control menu.

6.10.1. Ethernet Tab

Clicking on the Ethernet port icon opens the Port properties. The most important information and settings are available on the panel. *#ethernet*

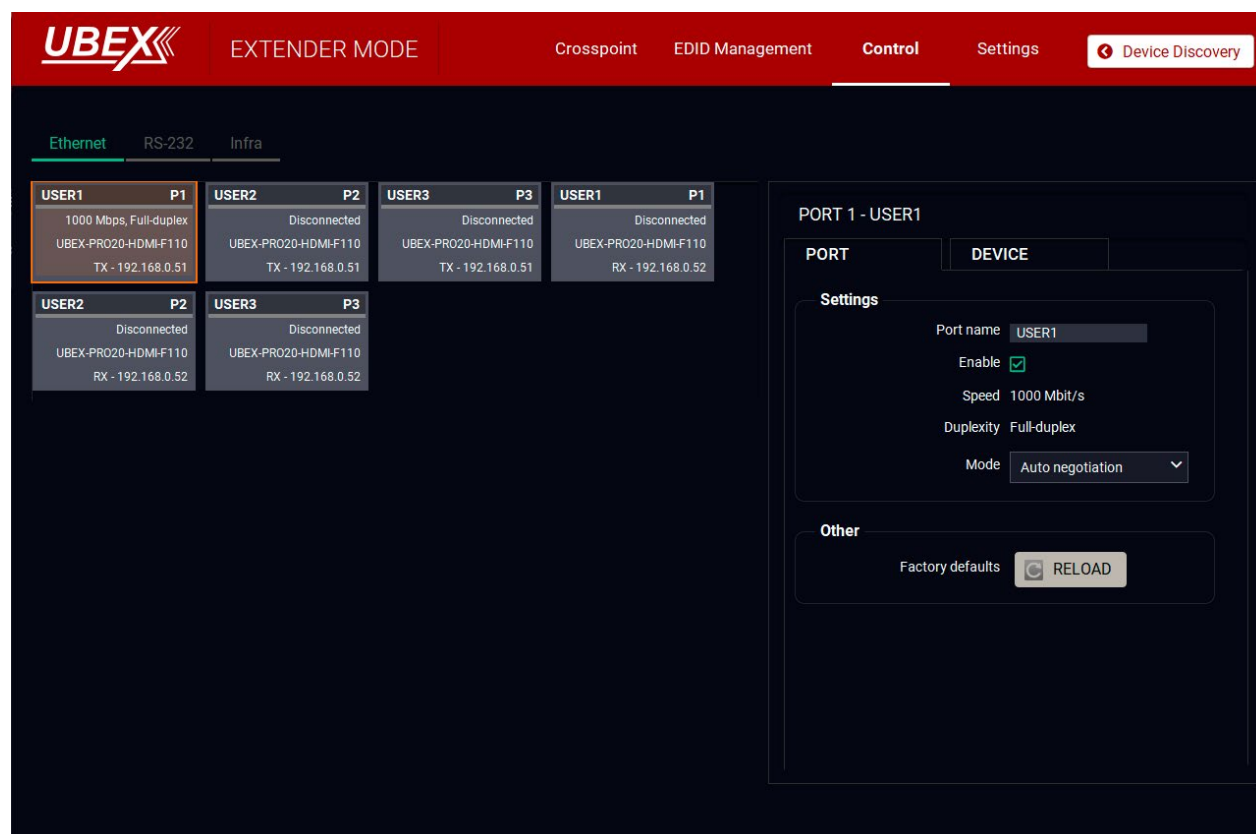

Ethernet tab in the Control menu

Available settings and tools:

- Port naming;
- **Enable/disable the port;**
- **Mode** (Auto negotiation / 10Mbps half-duplex / 10Mbps full-duplex / 100Mbps half-duplex / 100Mbps full-duplex / 1000Mbps full-duplex).
- **Reloading factory default settings** for the selected port.

6.10.2. RS-232 Tab

DIFFERENCE: Only the UBEX-PRO20-HDMI-F110, -F111, -F120, -F121 and F130 models are built with RS-232 port.

Clicking on the RS-232 port icon opens the Port properties. The most important information and settings are available on the panel. *#rs232 #rs-232 #serial*

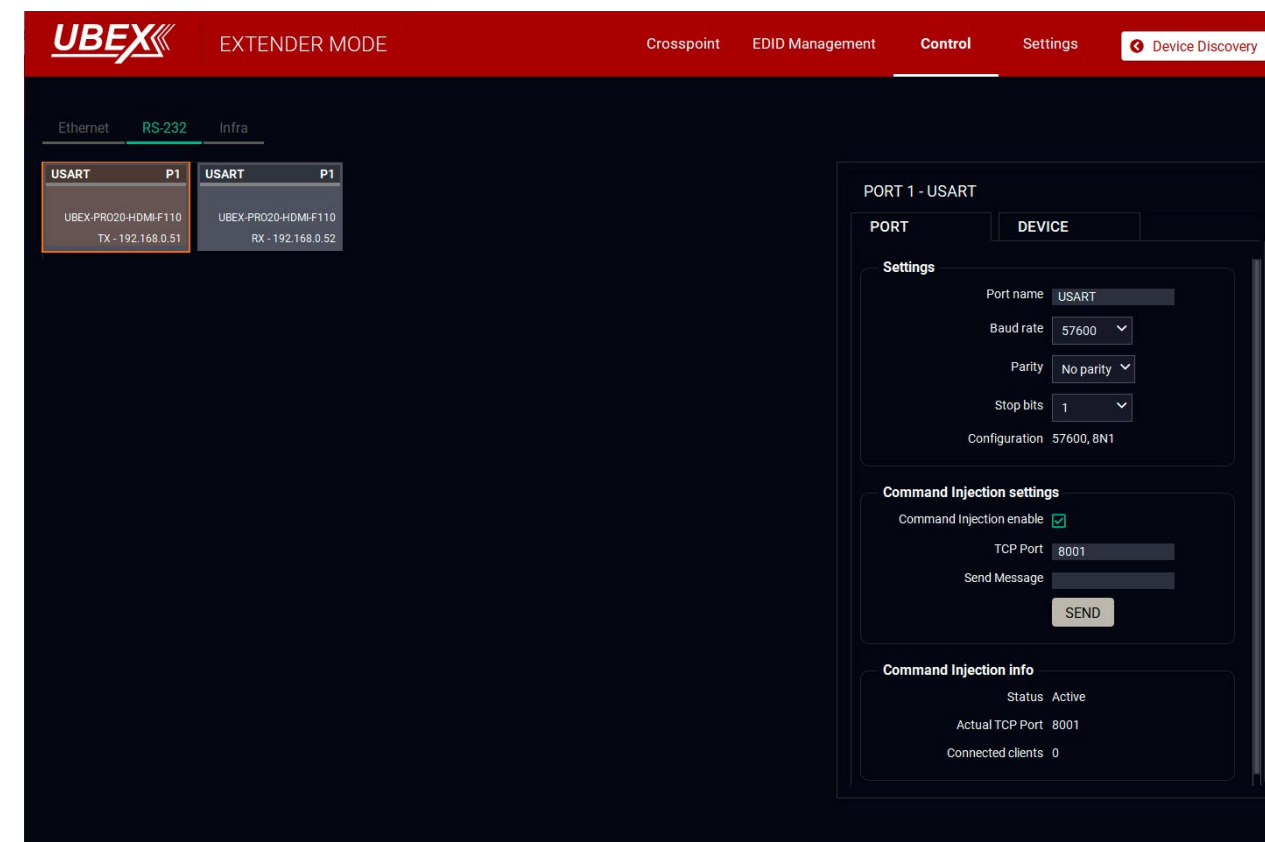

RS-232 tab in the Control menu

Available settings and tools:

- Port naming;
- **Baud rate** (4800 / 7200 / 9600 / 14400 / 19200 / 38400 / 57600 / 115200);
- **Parity** (None / Odd / Even);
- **Stop bits** (1 / 1.5 / 2);
- **Command Injection enable** (enable / disable);
- **TCP port number;**
- **Send message** field - see more details about it in the [Sending Message via RS-232 Interface](#) section;
- **Reloading factory default settings** for the selected port.

Sending Message via RS-232 Interface

The **Send message** is for sending a command message in ASCII-format. This method allows escaping the control characters. *#message*

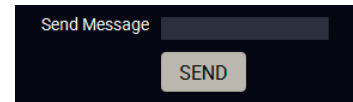

Escaping the Control Characters

DEFINITION: An escape sequence is a sequence of characters that does not represent itself when used inside a character or string literal, but is translated into another character or a sequence of characters.

The message can contain characters that are used as control characters in the protocol. They must be escaped. The escape character is the backslash ('\'), and escaping means injecting a backslash before the given character (like in C language).

Control characters are the followings: \ { } # % () \r \n \t

A typical usage when a message is sent and it contains such a character that must be escaped.

Example

The original message: Set(01)

The escaped message: Set\ (01\)

The case above is a typical example: the UBEX endpoint device is directed to send out a message over one of its ports. The round brackets in the message are escaped.

Using Hexadecimal Codes

Hexadecimal codes can be inserted in the ASCII message when using:

Message: C00\x0D

- **C00:** the message.
- **\x:** indicates that the following is a hexadecimal code.
- **0D:** the hexadecimal code (Carriage Return).

See more serial message sending methods using LW3 protocol commands in the [Sending a Text \(ASCII-format\) via Serial Port](#), [Sending a Binary Message \(HEX-format\) via Serial Port](#), and the [Sending a Message \(ASCII-format\) via Serial Port](#) sections.

6.10.3. Infra Tab

DIFFERENCE: Only UBEX-PRO20-HDMI-F110 and F120 models are built with Infrared input and output ports.

Clicking on an Infra port icon opens the Port properties. The most important settings are available on the panel. *#infra #ir #message*

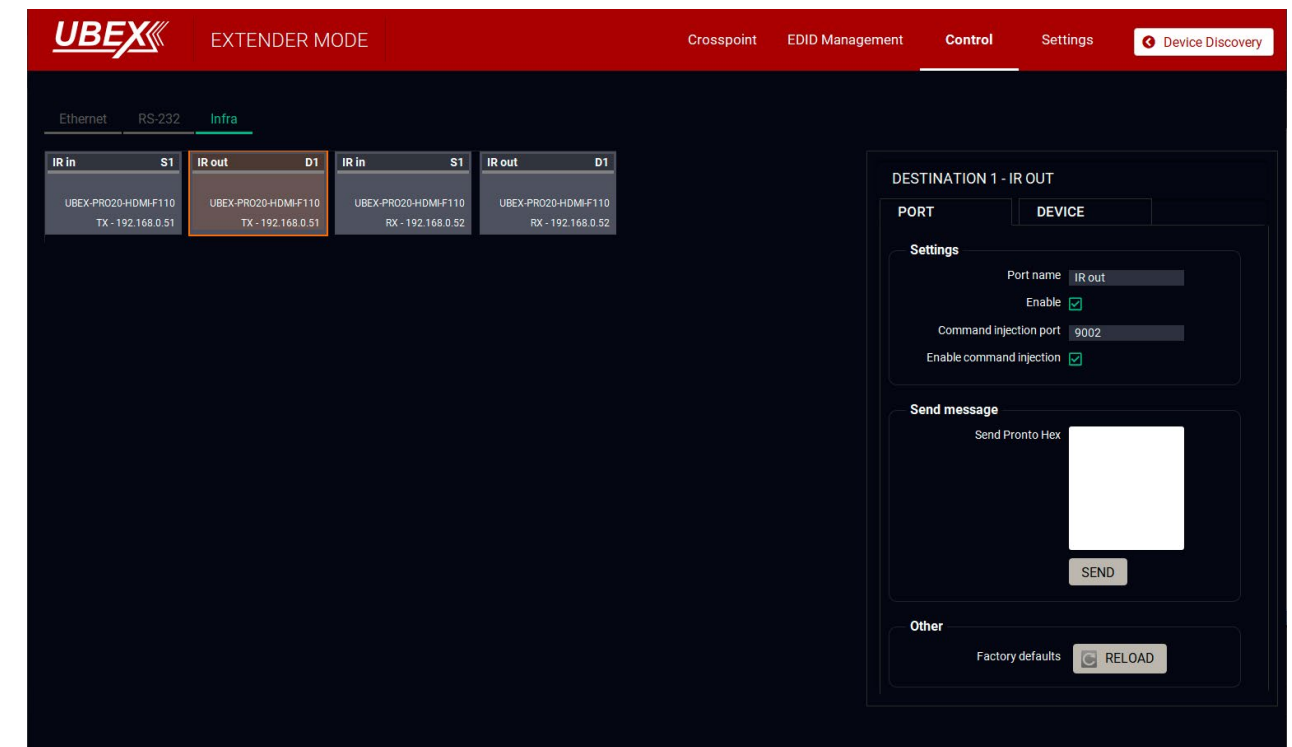

Infra tab in the Control menu

Available settings and tools:

- Port naming;
- **Enable/disable the port;**
- **Command injection port;**
- **Enable command Injection** (enable / disable);
- **Send message** (for IR out ports only): sending pronto hex message in little-endian format on the Infra output port.

ATTENTION: The device has no built-in Infrared receiver and transmitter. For the complete usage, attach an IR emitter unit to the IR OUT and an IR detector unit to the IR IN connectors.

INFO: You can send pronto hex message in **big-endian format** as well, using LW3 protocol command. See the details in the [Sending Hex Codes in Big-endian Format via IR Port](#) section.

6.10.4. USB Tab

DIFFERENCE: Only UBEX-PRO20-HDMI-F120 and -F121 endpoint models are built with USB K+M ports and only UBEX-PRO20-HDMI-F130 endpoint model is built with USB KVM ports. `#km #usbkm #kvm #usbkvm #icron`

INFO: The USB HID ports of the UBEX-PRO20-HDMI-F130 model can also be managed in this submenu. The parameter settings of the USB 2.0 ports will be added in a future LDC software update.

Emulated Devices

Clicking on a Local Emulated port icon opens the Port properties. The most important information is available on the panel.

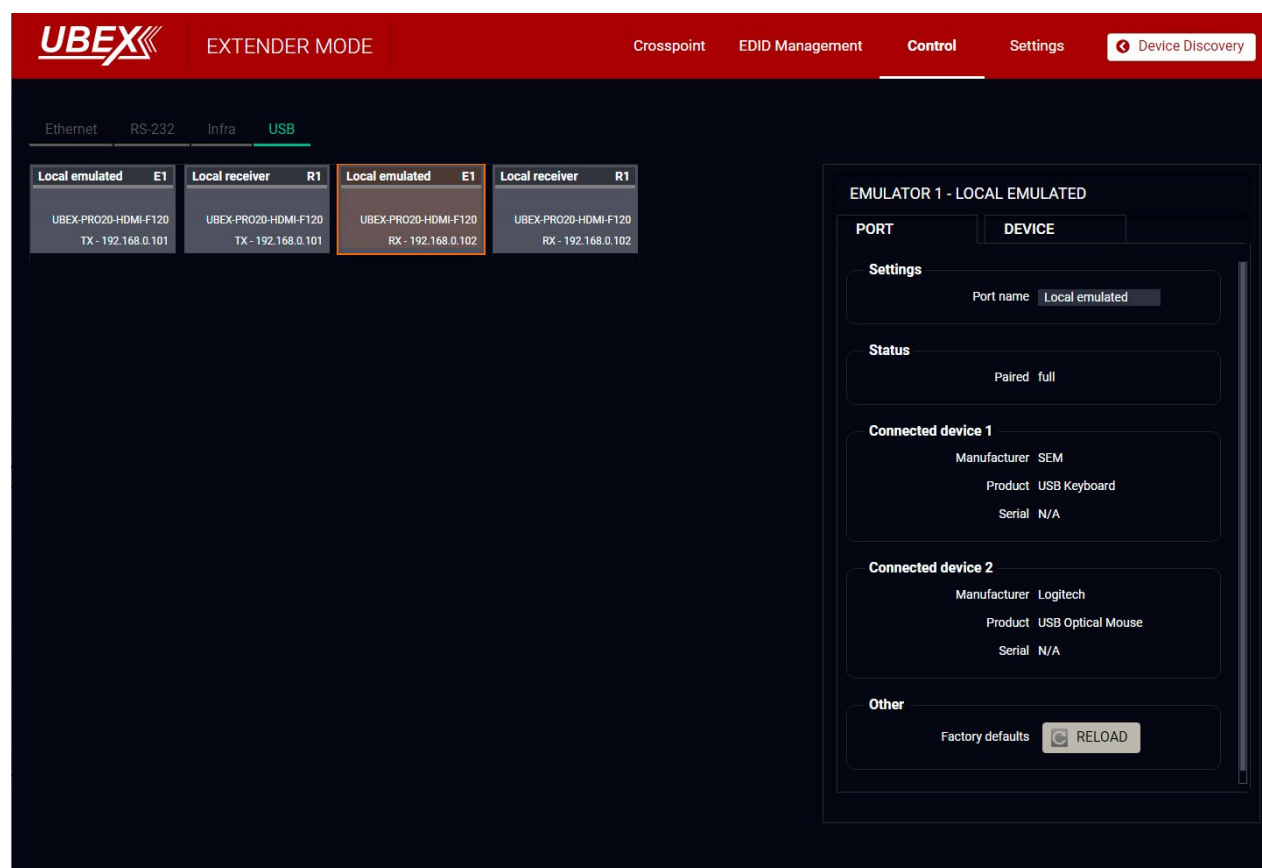

USB tab in the Control menu

Available settings and tools:

- Port naming;
- **Reloading factory default settings** for the selected port.

Receiver (Host) Devices

Clicking on a Local Receiver port icon opens the Port properties. The most important settings are available on the panel.

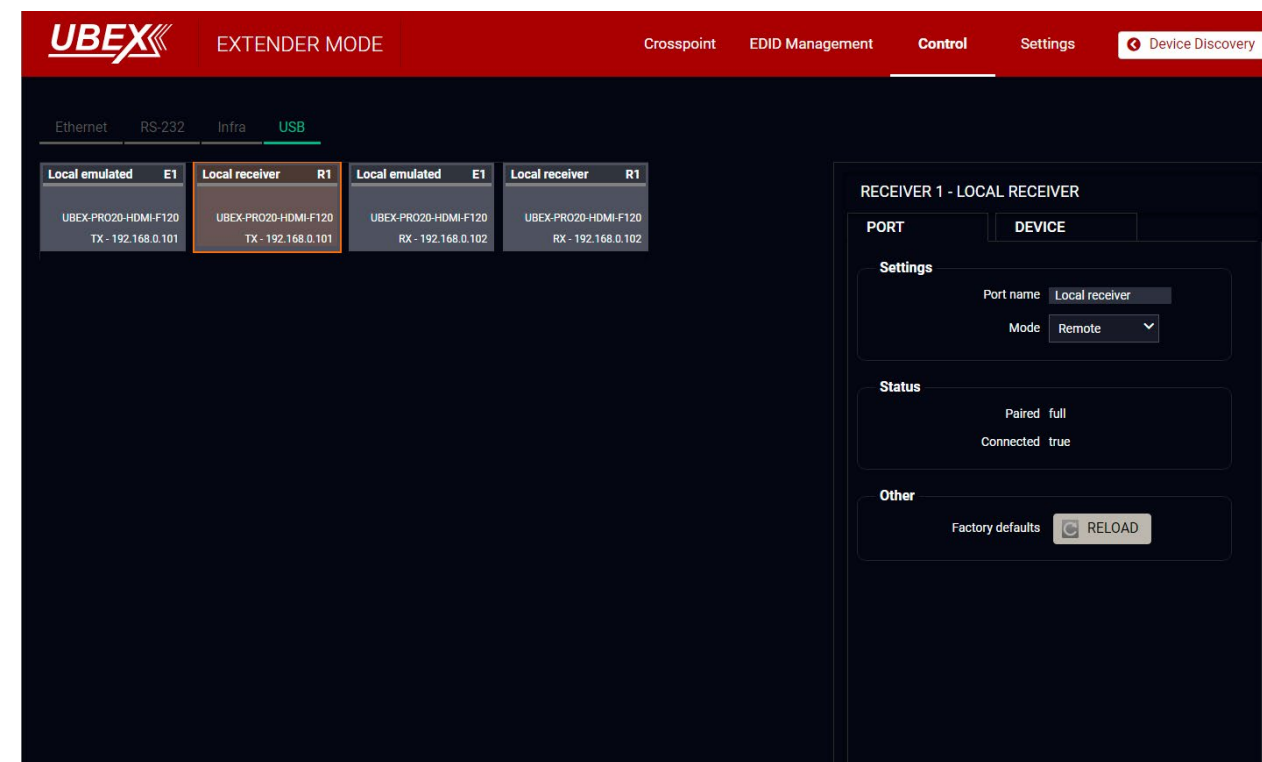

USB tab in the Control menu

Available settings and tools:

- Port naming;
- **Mode:**
 - **Disconnected:** no USB transmission between the endpoint devices.
 - **Local:** the emulated devices (keyboard and mouse) are connected to the local receiver (host) device in the same endpoint.
 - **Remote:** the emulated devices (keyboard and mouse) are connected to the remote receiver (host) of the connected endpoint device.

INFO: In case of F130 model it set the operation mode of the **USB HID** ports.

- **Reloading factory default settings** for the selected port.

ATTENTION: In case of F130 model the control mode sets the operation mode of the **USB HID ports only**. GUI support of the USB 2.0 ports will be added in a future LDC software update.

6.11. Settings Menu

INFO: The Settings menu is available for the transmitter, receiver and the transceiver separately. You can choose which device you want to configure.

INFO: The available settings are the same for all operation modes.

6.11.1. Status Tab

The screenshot shows the 'Settings (TX - 192.168.0.51)' page with the 'Status' tab selected. The page is divided into several sections:

- General:** Product name (UBEX-PRO20-HDMI-F110), MAC address (A8:D2:36:00:51:99), Hardware version (V13_AAAX), Display and Control module version (V10_CAAX), RS232, Audio and KVM add-on (V11_BAAX), Device label (UBEX-PRO20-HDMI-F), Part number (91820100), and Serial number (91137065). An 'IDENTIFY UNIT' button is present.
- Operation:** Current operation mode (Transmitter), Operation mode (Transmitter), System uptime (0 days 00h 42m 47s), Operation time (5 days 09h 07m 36s), and High temp operation time (0 days 00h 00m 00s).
- Firmware versions:** Package version (v1.5.0b5), CPU firmware version (v1.5.0b5), CPU firmware updater version (v1.3.0b3), CPU loader version (v1.0.2b1), FPGA Tx image version (v1.3.2b1), FPGA Tx image version (v1.1.2b1), FPGA Rx image version (v1.3.3b1), Rx video chip firmware version (v1.3.0b1), and Tx video chip firmware version (v2.0.0b1).
- Temperatures:** CPU Temperature (70.00 °C), System Temperature (80.00 °C), and FPGA Temperature (80.00 °C).
- Voltages:** Main 12 V (12.05 V), Main 5 V (5.11 V), Main 3.3 V (3.37 V), CPU 3.3 V (3.27 V), and FPGA 0.95 V (0.95 V).

Status tab in the Settings menu (TX)

The most important hardware and software related information can be found on this tab: hardware and firmware version, serial numbers, temperatures, operation time, and voltage information. **Device label** can be changed to unique description. `#status #firmwareversion #mac #identifyme #devicelabel #label #operationmode #transmitter #receiver #transceiver #tx #rx #trx`

Operation Mode

The operation mode - the unit works as a transmitter, a receiver or a transceiver - can be set on the Status tab. Follow the steps to change the current operation mode:

- Step 1.** Select the desired **Operation mode** (Transmitter / Receiver / Transceiver mode).
- Step 2.** Confirm your selection, press **OK**.
- Step 3.** Wait until the device reboots. After booting up, the endpoint operates in the selected operation mode.

Identify the Unit

Clicking on the **Identify unit** button makes the four front panel LEDs blink in green for 10 seconds. The feature helps to identify the device itself in the rack shelf.



6.11.2. Network Tab

The screenshot shows the 'Settings (TX - 192.168.0.51)' page with the 'Network' tab selected. The page displays the following network settings:

- Current IP address: 192.168.0.51
- Current subnet mask: 255.255.255.0
- Current gateway address: 192.168.0.1
- Obtain IP address automatically (DHCP, AutoIP):
- Static IP address: 192.168.0.51
- Static subnet mask: 255.255.255.0
- Static gateway address: 192.168.0.1

Buttons for 'APPLY CHANGES', 'CANCEL', and 'LOAD FACTORY DEFAULTS' are visible at the bottom.

Network tab in the Settings menu

IP address and DHCP settings can be set on this tab. Always press the **Apply settings** button to save changes.

Factory defaults settings can be recalled with a dedicated button. See the factory default settings of the endpoint device in the [Factory Default Settings](#) section. `#network #ipaddress #dhcp`

6.11.3. Front Panel Tab

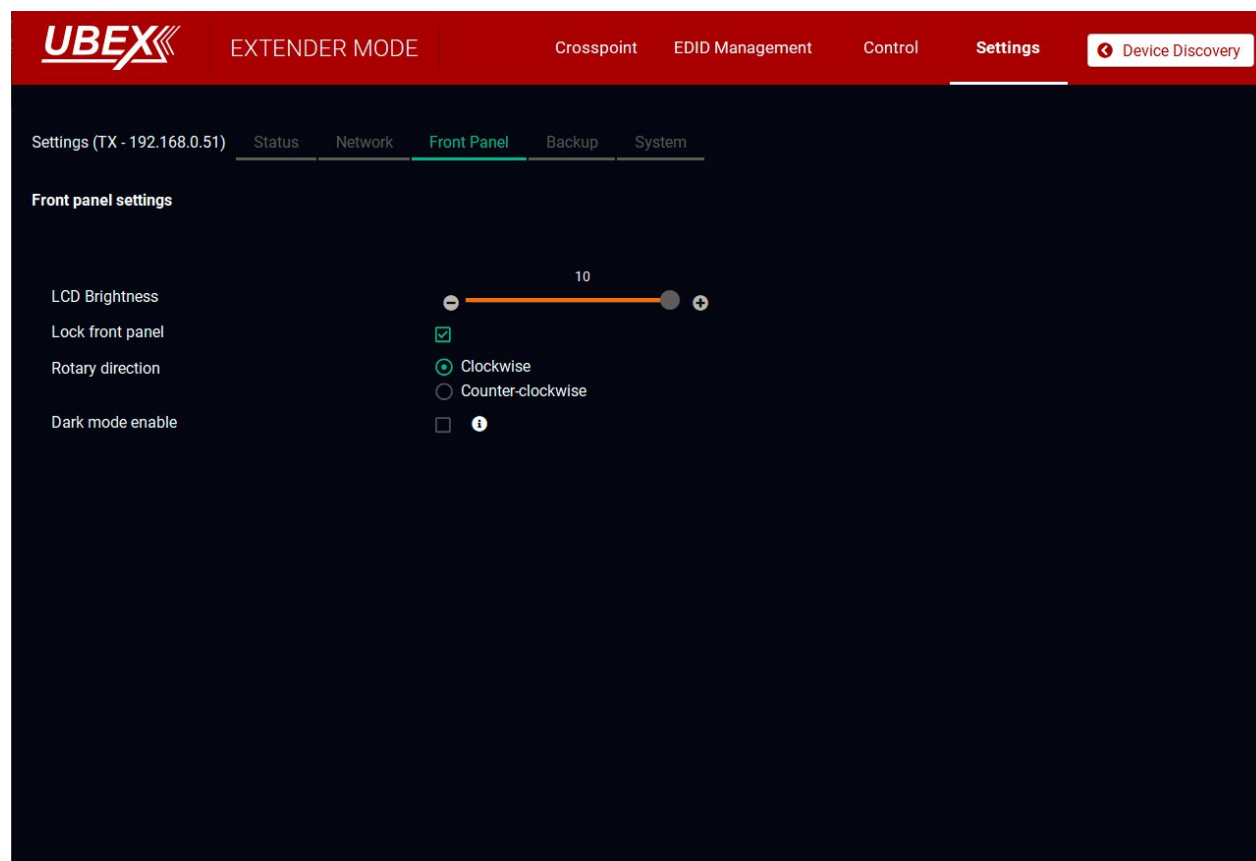

Front panel tab in the Settings menu

The following settings can be set under the Front panel tab:

- **LCD Brightness** - the brightness of the LCD can be set from 1 to 10 on a scale.
- **Lock front panel** - the operation of the jog dial control knob can be locked. The settings can be unlocked only by the LCD software or by an LW3 protocol command (see the details in the [Control Lock](#) section).
- **Rotary direction** - the rotary direction of the jog dial control knob can be set in two ways:
 - Clockwise
 - Counter-clockwise *#rotary #jogdial*
- **Dark mode** - the dark mode feature can be enabled or disabled. It keeps the LCD screen and the LEDs unlit to hide the device during an event when the mode is enabled. Pressing the rotatory knob in dark mode the display and LEDs will be enabled again for the configured dark mode timeout interval. *#darkmode*

6.11.4. System Tab

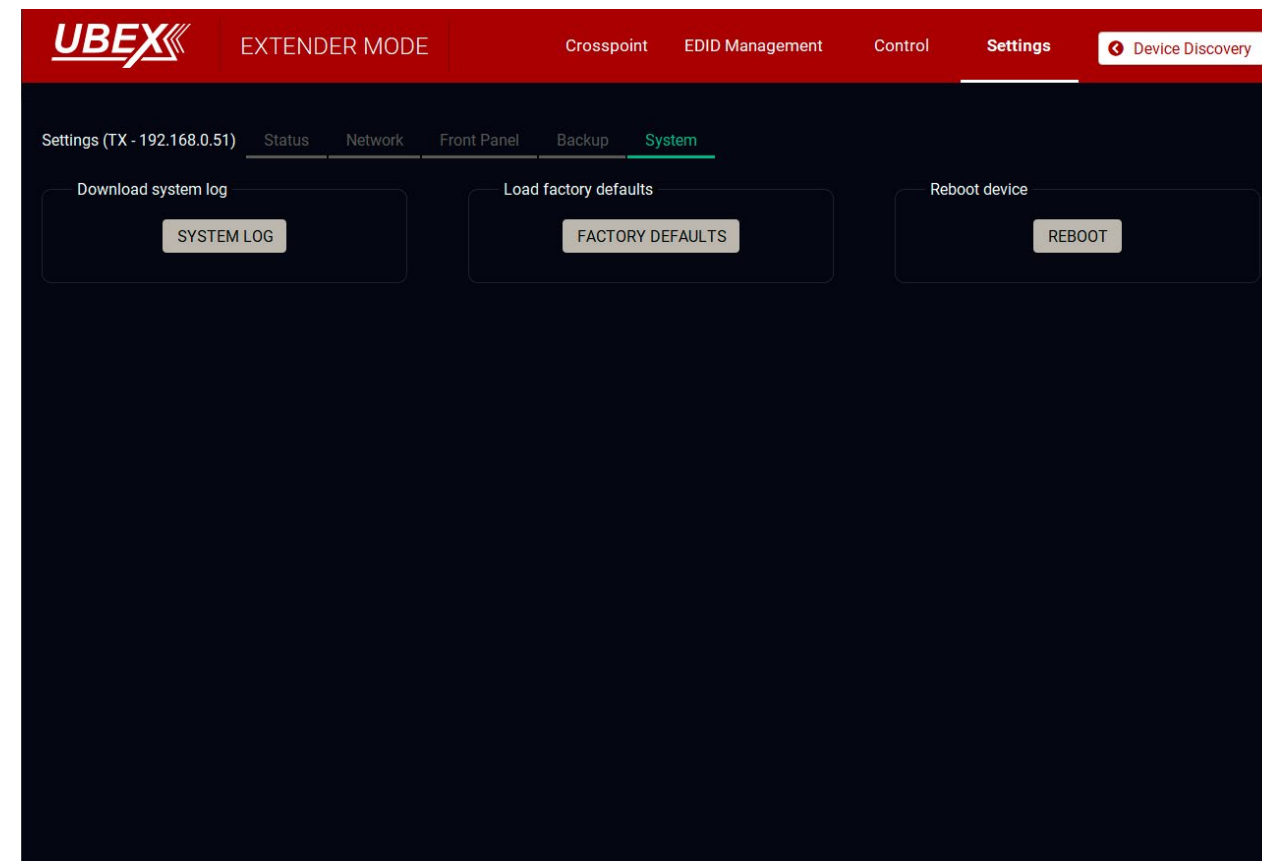

System tab in the Settings menu

Three functions are available under System tab:

- **System log** - saving the file of the device. *#log*
- **Factory defaults** - recalling factory defaults settings and values. All factory default settings of the endpoint device are listed in the [Factory Default Settings](#) section. *#factory*
- **Reboot** - rebooting the system. *#restart #reboot*

6.12. Configuration Cloning (Backup Tab)

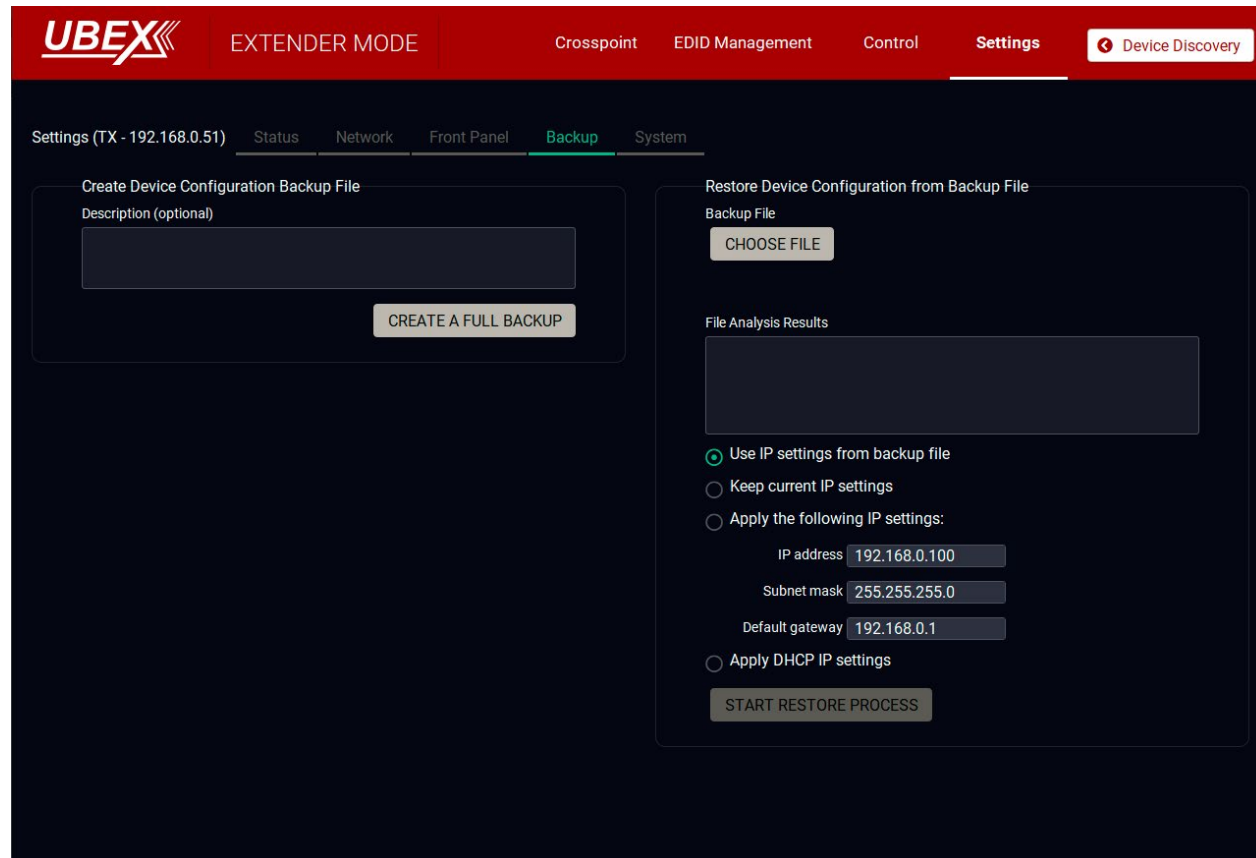

Backup tab

The configuration cloning of Lightware LW3 devices is a simple method that eliminates the need to repeatedly configure certain devices to have identical (non-factory) settings. If the devices are installed in the same type of system multiple times, then it is enough to set up only one device to fit the user's needs and then copy those settings to the others, thus saving time and resources. *#backup #configurationcloning*

6.12.1. Cloning Steps in a Nutshell

Installing multiple devices with the same customized configuration settings can be done in a few easy steps:

- Step 1.** Configure one device with all your desired settings with the LDC software.
- Step 2.** Backup the full configuration file to your computer.
- Step 3.** If needed, make some modifications to the configuration file using a text editor (e.g. Notepad). E.g. modifying the static IP address is needed when DHCP is not used.
- Step 4.** Connect to the other device that has to be configured and upload (restore) your configuration file.
- Step 5.** Done! You can have as many entirely identical, customized devices as you like.

6.12.2. Save the Settings of the Device (Backup)

- Step 1.** Apply the desired settings in the device (port parameters, crosspoint, etc.)
- Step 2.** Select the **Settings / Backup** tab from the menu.
- Step 3.** Write a short **description** in the text box on the left (optional).
- Step 4.** Press the **Create a full backup** button. You will be prompted to save the file to the computer. The default file name is the following:

BACKUP_<DEVICE LABEL>_SN<SERIAL NUMBER>.LW3

- Step 5.** Set the desired **file name**, select the folder and **save** the file.

TIPS AND TRICKS: Using the exact product type in the filename is recommended, since it makes the file usage more convenient.

About the Backup File

The backup file is a simple text file that contains LW3 protocol commands. The first line is the description, and the further lines are the commands that will be executed during the restore process. The file can be viewed (and/or edited) using a simple text editor, e.g. Notepad.

ATTENTION: Editing the command lines is only recommended for expert users.

See the entire list of saved data in the [Content of Backup File](#) section.

6.12.3. Upload the Settings to a Device (Restore)

WARNING! The configuration file is compatible with the same operation mode that is in the file. The file of a transmitter can be restored to a transmitter, the file of a receiver can be restored to a receiver, and the file of a transceiver can be restored to a transceiver only!

WARNING! Please note that the settings will be permanently overwritten with the restored parameters in the device. Recovery of the original settings is not possible.

ATTENTION: The cloning is only successful when the backup file is downloaded from the same type of source device as the destination device.

The Restoring Process

- Step 1.** Select the **Settings / Backup** tab from the menu.
- Step 2.** Click on the **Choose file** button on the right panel and **browse** the desired file.
- Step 3.** The file is checked and the result will be displayed in the textbox below. If the file is correct, the settings can be restored.
- Step 4.** Choose the **IP settings** that you want to use after backup. You can apply settings from the backup file, keep actual settings, set it manually in a dialog box or apply DHCP.
- Step 5.** Press the **Start restore process** button and click on the **Yes** button when asked.
- Step 6.** Reboot the device to apply the network settings after finishing.

6.13. Terminal Window

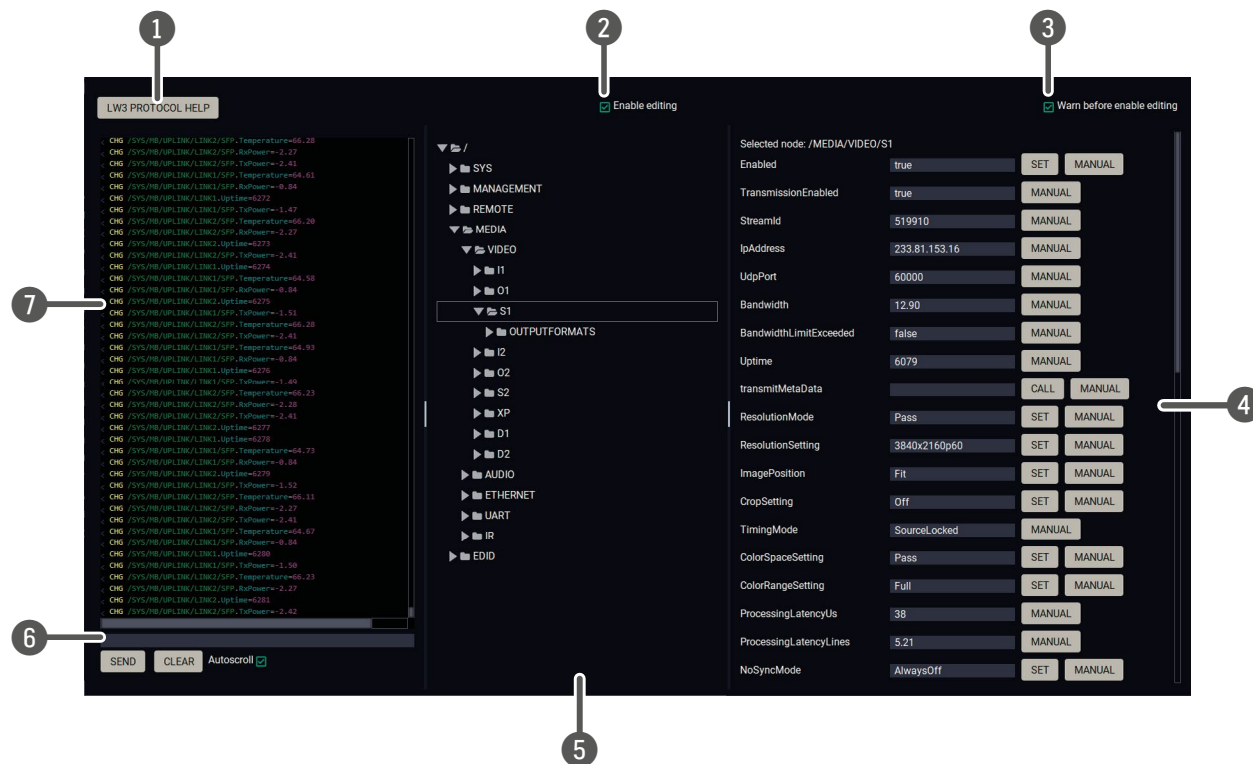

- 1 **LW3 protocol help** Pushing the button results in a help window opening, which describes the most important information about LW3 protocol commands in HTML format.
- 2 **Edit mode** The default appearance is the read-only mode. If you want to modify the values or parameters, tick the option. You will be prompted to confirm your selection.
- 3 **Warning mode** If this is checked, a warning window pops up when you enable Edit mode.
- 4 **Node list** Correspondent parameters and nodes are shown that are connected to the selected item in the protocol tree.
Manual button: Manual (short description) of the node can be called and displayed in the terminal window.
Set button: Saves the value/parameter typed in the textbox.
Call button: Calls the method, e.g. reloads factory default settings.
- 5 **Protocol tree** LW3 protocol tree; select an item to see its content.
- 6 **Command line** Type the desired command and execute it by the **Send** button. Clear all current commands and responses in the Terminal window by the **Clear** button.
- 7 **Terminal window** Commands and responses with time and date are listed in this window. Sent command starts with '**>**' character, received response starts with '**<**' character. The color of each item depends on the type of the command and the response. The content of the window can be emptied by the **Clear** button. If the **Autoscroll** option is ticked, the list is scrolled automatically when a new line is added.

#advancedview #terminal

7

Programmers Reference

The device can be controlled through **Lightware 3 (LW3)** protocol commands to ensure the compatibility with other Lightware products. The supported LW3 commands are described in this chapter.

▶ Overview	114
▶ Instructions for the Terminal Application Usage	114
▶ Protocol Rules	114
▶ System Commands	117
▶ Video Port Settings - Transmitter Mode	121
▶ Video Port Settings - Receiver Mode	127
▶ Video Port Settings - Transceiver Mode	133
▶ Multiviewer Configuration	140
▶ Audio Port Settings	145
▶ Analog Audio Port Settings	147
▶ System Monitoring Commands	148
▶ SFP+ Module Information	150
▶ EDID Management	152
▶ Network Configuration	153
▶ RS-232 Port Configuration	154
▶ Infrared Port Configuration	156
▶ Message Sending via Communication Ports	156
▶ USB K+M Settings (F120 / F121 Models)	158
▶ USB KVM Settings (F130 Model)	160
▶ LW3 Protocol Commands - Quick Summary	164

7.1. Overview

The Lightware Protocol #3 (LW3) is implemented in almost all new Lightware devices (matrix switchers, signal extenders and distribution amplifiers) since 2012. The protocol is ASCII-based and all commands are terminated with a carriage return (Cr, '\r') and line feed (Lf, '\n') pair. It is organized as a tree structure that provides outstanding flexibility and user-friendly handling with 'nodes', 'properties' and 'methods'. The [Terminal Window](#) of the Lightware Device Controller software is the perfect tool for browsing and learning how the LW3 protocol can be used in practice.

7.2. Instructions for the Terminal Application Usage

Terminal Application

The LW3 protocol commands can be applied to the UBEX endpoint devices using a terminal application. You need to install one of them to your control device, for example **Putty** or **CLI**. `#terminal`

Establishing Connection

Follow the steps for establishing connection to the endpoints:

- Step 1.** Connect the device to a LAN over Ethernet (see the details in the [Connections](#) section).
- Step 2.** Open the terminal application (e.g. Putty).
- Step 3.** Add the **IP address** of the device (default for TX/TRX: 192.168.0.101; default for RX: 192.168.0.102) and the **port number (6107)**.
- Step 4.** Select the **Raw** connection type, and open the connection.

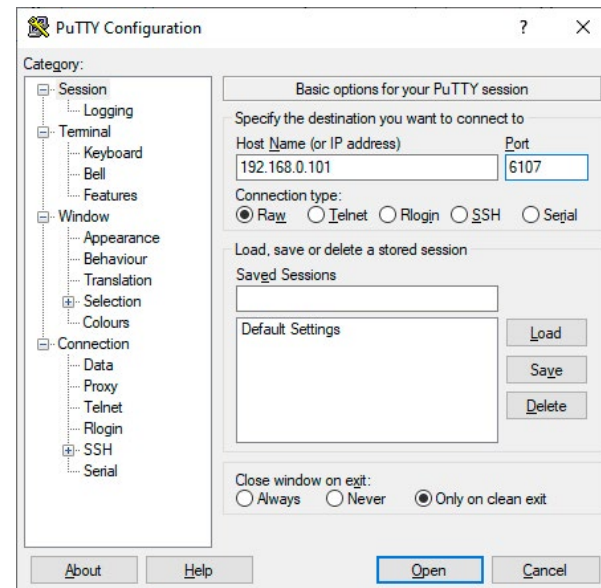

Once the terminal window is opened, you can enter the LW3 protocol commands, which are listed in the following sections.

```

1700#GET /EDID.*
{1700
pr /EDID.EdidStatus=D3:E1;D3:E2
m- /EDID:copy
m- /EDID:delete
m- /EDID:reset
m- /EDID:switch
m- /EDID:switchAll
}
GET /MANAGEMENT/LABEL.DeviceLabel
pw /MANAGEMENT/LABEL.DeviceLabel=UBEX-PRO20-HDMI-F110

```

LW3 protocol command communication in a terminal window

7.3. Protocol Rules

7.3.1. LW3 Tree Structure and Command Structure (Examples)

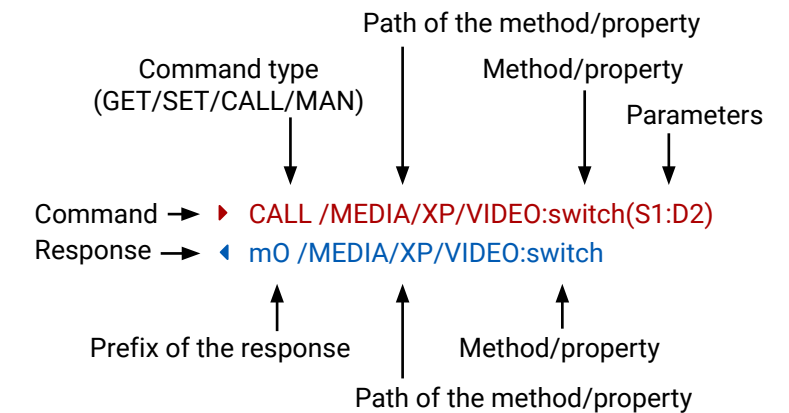
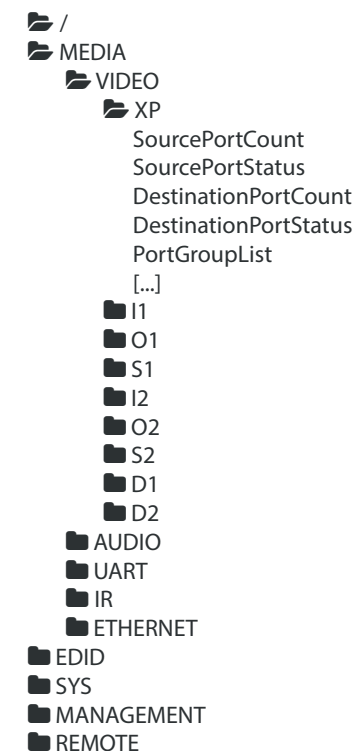

7.3.2. General Rules

- All names and parameters are **case-sensitive**.
- The nodes are separated by a slash ('/') character.
- The node names are comprised of the elements of the English alphabet and numbers.
- Use the **TCP port no. 6107** when using LW3 protocol over Ethernet.
- Node paths describe the exact location of the node, listing each parent node up to the root.
- The length of a line (command/response, command type / prefix, path, method/property and parameters together) can be max. 800 bytes.
- The command lines have to be closed by Carriage return and Line Feed (CrLf)

7.3.3. Command Types

GET command

The **GET** command can be used to get the child nodes, properties and methods of a specific node. It can also be used to get the value of a property. Use the dot character (.) when addressing a property:

- ▶ **GET /.SerialNumber**
- ◀ **pr /.SerialNumber=87654321**

GETALL command

The **GETALL** command can be used to get all child nodes, properties and methods of a node with one command.

- ▶ **GETALL /EDID**
- ◀ **n- /EDID/F**
- ◀ **n- /EDID/D**
- ◀ **n- /EDID/U**
- ◀ **n- /EDID/E**
- ◀ **pr /EDID.EdidStatus=D3:E1;D3:E2**
- ◀ **m- /EDID:copy**
- ◀ **m- /EDID:delete**
- ◀ **m- /EDID:reset**
- ◀ **m- /EDID:switch**
- ◀ **m- /EDID:switchAll**

SET command

The **SET** command can be used to modify the value of a property. Use the dot character (.) when addressing the property:

- ▶ **SET /MEDIA/VIDEO/01.HdcpMode=Always**
- ◀ **pw /MEDIA/VIDEO/01.HdcpMode=Always**

CALL command

A method can be invoked by the **CALL** command. Use the colon character (:) when addressing the method:

- ▶ **CALL /MEDIA/VIDEO/XP:switch(S1:D1)**
- ◀ **mO /MEDIA/VIDEO/XP:switch**

MAN command

The manual is a human readable text that describes the syntax and provides a hint on how to use the primitives. For every node, property and method in the tree, there is a manual; type the **MAN** command to get the manual:

- ▶ **MAN /MEDIA/VIDEO/01.Output5vMode**
- ◀ **pm /MEDIA/VIDEO/01.Output5vMode ["Auto" | "AlwaysOn" | "AlwaysOff"]**

7.3.4. Prefix Summary

DEFINITION: The prefix is a 2-character-long code that describes the type of the response.

The following prefixes are defined in the LW3 protocol:

Prefix	Description
n-	a node
nE	an error for a node
nm	a manual for a node
pr	a read-only property
pw	read-write property
pE	an error for the property
pm	a manual for the property
m-	a method
mO	a response after a successful method execution
mF	a response after a failed method execution
mE	an error for a method
mm	a manual for a method

7.3.5. Error Messages

There are several error messages defined in the LW3 protocol, all of them have a unique error number.

- ▶ **CALL /MEDIA/VIDEO/XP:switch(SA:D1)**
- ◀ **mE /MEDIA/VIDEO/XP:switch %E004:Invalid value**

7.3.6. Escaping

DEFINITION: An escape sequence is a sequence of characters that does not represent itself when used inside a character or string literal, but is translated into another character or a sequence of characters.

Property values and method parameters can contain characters that are used as control characters in the protocol. They must be escaped. The escape character is the backslash ('\'), and escaping means injecting a backslash before the character that should be escaped (like in C language).

Control characters are the following: \ { } # % () \r \n \t

The **original** message: **CALL /MEDIA/UART/P1:sendMessage(Set(01))**

The **escaped** message: **CALL /MEDIA/UART/P1:sendMessage(Set\01\)**

7.3.7. Signature

DEFINITION: The signature is a four-digit-long hexadecimal value that can be optionally placed before every command to keep a command and the corresponding responses together as a group.

Each line is terminated with carriage return (Cr, '\r') and line feed (Lf, '\n') characters. In several cases the number of the lines in the response cannot be determined in advance, e.g. the client intends to receive the whole response and also wants to be sure that the received lines belong together and to the same command. In these cases, a special feature, the 'signature' can be used. The response to that particular command will also be preceded by the signature, and the corresponding lines will be between brackets:

```
▶ 1700#GET /EDID.*
◀ {1700
◀ pr /EDID.EdidStatus=F147:E1;D1:E2
◀ m- /EDID:copy
◀ m- /EDID:delete
◀ m- /EDID:reset
◀ m- /EDID:switch
◀ m- /EDID:switchAll
◀ }
```

INFO: The lines of the signature are also Cr and Lf terminated.

7.3.8. Subscription

DEFINITION: Subscription to a node means that the user will get a notification if a property of the node changes.

A user can subscribe to any node. These notifications are asynchronous messages and are useful to keep the client application up to date, without having to periodically poll the node to detect a changed property. When the user does not want to be informed about the changes anymore, he can simply unsubscribe from the node.

ATTENTION: The subscriptions are handled separately for connections. Hence, if the connection is terminated, all registered subscriptions are deleted. After reopening a connection all subscribe commands have to be sent in order to get the notifications of the changes on that connection.

Subscribe to a Node

```
▶ OPEN /MEDIA/VIDEO
◀ o- /MEDIA/VIDEO
```

Subscribe to Multiple Nodes

```
▶ OPEN /MEDIA/VIDEO/*
◀ o- /MEDIA/VIDEO/*
```

Unsubscribe from a Node

```
▶ CLOSE /MEDIA/VIDEO
◀ c- /MEDIA/VIDEO
```

Get the Active Subscriptions

```
▶ OPEN
◀ o- /MEDIA/VIDEO
◀ o- /EDID
◀ o- /DISCOVERY
```

Unsubscribe from Multiple Nodes

```
▶ CLOSE /MEDIA/VIDEO/*
◀ c- /MEDIA/VIDEO/*
```

7.3.9. Notifications about the Changes of the Properties

When the value of a property is changed and the user is subscribed to the node that the property belongs to, an asynchronous notification is generated. This notification is called the 'change message'. The format of such a message is very similar to the response for the GET command:

```
◀ CHG /EDID.EdidStatus=F48:E1
```

A Short Example of How to Use the Subscription

There are two independent users controlling the device through two independent connections (**Connection #1** and **Connection #2**). The events in the rows occur after each other.

▶ OPEN /MANAGEMENT/LABEL ◀ o- /MANAGEMENT/LABEL ▶ GET /MANAGEMENT/LABEL.DeviceLabel ◀ pm /MANAGEMENT/LABEL.DeviceLabel=UBEX-PRO20-HDMI-F120	connection #1
▶ GET /MANAGEMENT/LABEL.DeviceLabel ◀ pm /MANAGEMENT/LABEL.DeviceLabel=UBEX-PRO20-HDMI-F120 ▶ SET /MANAGEMENT/LABEL.DeviceLabel=TX_ServerRoom ◀ pw /MANAGEMENT/LABEL.DeviceLabel=TX_ServerRoom	connection #2
◀ CHG /MANAGEMENT/LABEL.DeviceLabel=TX_ServerRoom	connection #1

Explanation: The first user (**Connection #1**) set a subscription to a node. Later the other user (**Connection #2**) made a change, and thanks to the subscription, the first user got a notification about the change.

7.3.10. Legend for the Control Commands

Format	Description
<in>	Input port number
<out>	Output port number
<source>	Source stream ID
<destination>	Destination stream ID
<link>	SFP+ link number
<port>	Interface port number
<tile>	Multiviewer tile ID
<parameter>	Specific property defined and described in the command
<expression>	Batched argument: the underline means that more expressions or parameters can be placed using a semicolon, e.g. S1;S2 or S1:D2;S2:D1
▶	Sent command
◀	Received response
•	Space character
	Separator line ("or" character)

7.4. System Commands

7.4.1. Set the Device Label

INFO: The device label can be changed to a custom text in the [Status Tab](#) of the LDC software.

This property can be changed to a custom text. The default format of the device label is the following:
LW_<product_name>_<serial_no>

The Device Label can be 64 characters long and ASCII characters are allowed. Longer names will be truncated.

Command and Response *#devicelabel #label*

- ▶ SET•/MANAGEMENT/LABEL.DeviceLabel=<Custom_name>
- ◀ pw•/MANAGEMENT/LABEL.DeviceLabel=<Custom_name>

The Device Label can be 39 characters long and ASCII characters are allowed. Longer names will be truncated.

Example

- ▶ SET /MANAGEMENT/LABEL.DeviceLabel=UBEX-RX_Conference
- ◀ pw /MANAGEMENT/LABEL.DeviceLabel=UBEX-RX_Conference

7.4.2. Querying the Product Name

ATTENTION: The name of the product is a read-only parameter and cannot be modified.

Command and Response

- ▶ GET•/.ProductName
- ◀ pr•/.ProductName=<Product_name>

Example

- ▶ GET /.ProductName
- ◀ pr /.ProductName=UBEX-PRO20-HDMI-F121

7.4.3. Query the Firmware Package Version

Command and Response *#firmwareversion*

- ▶ GET•/MANAGEMENT/UID/PACKAGE.Version
- ◀ pr•/MANAGEMENT/UID/PACKAGE.Version =<firmware_version>

Example

- ▶ GET /MANAGEMENT/UID/PACKAGE.Version
- ◀ pr /MANAGEMENT/UID/PACKAGE.Version=v3.4.0b7

7.4.4. Display Custom Text on the LCD

Calling the method makes a custom message display on the LCD screen for 5 seconds. This feature can be used to help to identify the device itself in the rack shelf.



ATTENTION: Applying of escaping is required in this method. See the details about it in the [Escaping](#) section.

INFO: The following characters are not allowed in the <text> parameter: () { } # % \ \r \n \t

Command and Response

- ▶ CALL•/MANAGEMENT/UI:displayMessage(<text>)
- ◀ mO•/MANAGEMENT/UI:displayMessage

Example

- ▶ CALL /MANAGEMENT/UI:displayMessage(I'm here!)
- ◀ mO /MANAGEMENT/UI:displayMessage

7.4.5. Display Custom Color on the LCD

Calling the method makes a custom color display on the LCD screen until withdrawal. This feature can be used to help to identify the device itself in the rack shelf.



Command and Response

- ▶ CALL•/MANAGEMENT/UI:testDisplay(<mode>,<hex_code>)
- ◀ mO•/MANAGEMENT/UI:testDisplay

Parameters

Parameter	Parameter description	Value	Value description
<mode>	Enable or disable the feature	0	The feature is disabled.
		1	The feature is enabled.
<hex_code>	6-character-long hexadecimal RGB color code	RGB color code	RGB color code

Example

- ▶ CALL /MANAGEMENT/UI:testDisplay(1,FFFF00)
- ◀ mO /MANAGEMENT/UI:testDisplay

Explanation

The whole LCD screen displays a yellow color.

7.4.6. Identify the Device

Calling the method results in the blinking of the front panel status LEDs for 10 seconds. This feature can be used to help to identify the device itself in the rack shelf.

Command and Response #identifyme

- ▶ CALL•/MANAGEMENT/UI:identifyMe()
- ◀ mO•/MANAGEMENT/UI:identifyMe



Example

- ▶ CALL /MANAGEMENT/UI:identifyMe()
- ◀ mO /MANAGEMENT/UI:identifyMe

7.4.7. Dark Mode Setting

Rental application requires this function, which keeps the LCD screen and the LEDs unlit to hide the device during an event. Pressing the rotatory knob in dark mode the display and LEDs will be enabled again for the configured dark mode timeout interval.



Command and Response #darkmode

- ▶ SET•/MANAGEMENT/UI/DARKMODE.DarkModeEnable=<logical_value>
- ◀ pw•/MANAGEMENT/UI/DARKMODE.DarkModeEnable=<logical_value>

Parameters

Parameter	Parameter description	Value	Value description
<logical_value>	Enable or disable the dark mode feature	true	Dark mode will be enabled after the delay time expired (see next section).
		false	Dark mode is disabled.

Example

- ▶ SET /MANAGEMENT/UI/DARKMODE.DarkModeEnable=true
- ◀ pw /MANAGEMENT/UI/DARKMODE.DarkModeEnable=true

7.4.8. Dark Mode Delay Setting

When the dark mode feature is enabled (see the previous section), it will be launched after the delay time expired.

Command and Response

- ▶ SET•/MANAGEMENT/UI/DARKMODE.DarkModeDelay=<second>
- ◀ pw•/MANAGEMENT/UI/DARKMODE.DarkModeDelay=<second>

Example

- ▶ SET /MANAGEMENT/UI/DARKMODE.DarkModeDelay=10
- ◀ pw /MANAGEMENT/UI/DARKMODE.DarkModeDelay=10

7.4.9. Query the Operation Mode

Command and Response

- ▶ GET•/SYS/MB.OperationMode
- ◀ pr•/SYS/MB.OperationMode=<operation_mode>

Parameters

Parameter	Parameter description	Value	Value description
<operation_mode>	The operation mode of the endpoint device	Transmitter	The endpoint device operates as a Transmitter . See the details in the Transmitter Mode section.
		Receiver	The endpoint device operates as a Receiver . See the details in the Receiver Mode section.
		Transceiver	The endpoint device operates as a Transceiver . See the details in the Transceiver Mode section.
		Multiviewer	The endpoint device operates as a Multiviewer . See the details in the Multiviewer Mode section.

Example

- ▶ GET /SYS/MB.OperationMode
- ◀ pr /SYS/MB.OperationMode=Transceiver

#operationmode #transmitter #receiver #transceiver #tx #rx #trx

7.4.10. Set the Operation Mode

ATTENTION: This operation always requires rebooting the device.

The operation mode (transmitter, receiver, transceiver or multiviewer) of the device can be changed based on the required application. `#operationmode #transmitter #receiver #transceiver #multiviewer #tx #rx #trx #rxmv`

Command and Response

- ▶ `CALL•/SYS/MB.setOperationModeAndReset=<operation_mode>`
- ◀ `mO•/SYS/MB.setOperationModeAndReset=<operation_mode>`

Parameters

Parameter	Parameter description	Value	Value description
<operation_mode>	The operation mode of the endpoint device	Transmitter	The endpoint device is set to Transmitter operation mode. See the details in the Transmitter Mode section.
		Receiver	The endpoint device is set to Receiver operation mode. See the details in the Receiver Mode section.
		Transceiver	The endpoint device is set to Transceiver operation mode. See the details in the Transceiver Mode section.
		Multiviewer	The endpoint device is set to Multiviewer . See the details in the Multiviewer Mode section.

Example

- ▶ `CALL /SYS/MB.setOperationModeAndReset=Transmitter`
- ◀ `mO /SYS/MB.setOperationModeAndReset=Transmitter`

7.4.11. Query the Application Mode

The application mode of the device can be Extender or Matrix. See the details about the two modes in the [Application Modes](#) section.

Command and Response `#applicationmode #extendermode #matrixmode`

- ▶ `GET•/SYS/MB.ApplicationMode`
- ◀ `pr•/SYS/MB.ApplicationMode=<application_mode>`

Parameters

Parameter	Parameter description	Value	Value description
<application_mode>	The application mode of the endpoint device.	Extender	The endpoint device is in Extender mode.
		Matrix	The endpoint device is in Matrix mode.

Example

- ▶ `GET /SYS/MB.ApplicationMode`
- ◀ `pr /SYS/MB.ApplicationMode=Extender`

7.4.12. Application Mode Selection

INFO: See the details about the two modes in the [Application Modes](#) section.

INFO: The **Auto** mode is the recommended application mode setting.

Command and Response

- ▶ `SET•/SYS/MB.ApplicationModeSelection=<application_mode>`
- ◀ `pw•/SYS/MB.ApplicationModeSelection=<application_mode>`

Parameters

Parameter	Parameter description	Value	Value description
<application_mode>	The application mode of the endpoint device.	Auto	The endpoint device detects the application mode automatically based on the connected remote device.
		Extender	The endpoint device is forced to be in Extender mode.
		Matrix	The endpoint device is forced to be in Matrix mode.

Example

- ▶ `SET /SYS/MB.ApplicationModeSelection=Auto`
- ◀ `pw /SYS/MB.ApplicationModeSelection=Auto`

7.4.13. Setting the Rotary Direction of the Jog Dial Knob

Command and Response *#rotary #jogdial*

- ▶ SET•/MANAGEMENT/UI.RotaryDirection=<parameter>
- ◀ pw•/MANAGEMENT/UI.RotaryDirection=<parameter>

Parameters

Parameter	Parameter description	Value	Value description
<parameter>	Rotary direction of the jog dial control knob	0	The rotary direction of down is clockwise (CW).
		1	The rotary direction of down is counter clockwise (CCW).

Example

- ▶ SET /MANAGEMENT/UI.RotaryDirection=1
- ◀ pw /MANAGEMENT/UI.RotaryDirection=1

7.4.14. Setting the Brightness of the LCD Screen

Command and Response

- ▶ SET•/MANAGEMENT/UI.DisplayBrightness=<parameter>
- ◀ pw•/MANAGEMENT/UI.DisplayBrightness=<parameter>

Parameters

The <parameter> of display brightness can be set between 0 and 10 values.

Example

- ▶ SET /MANAGEMENT/UI.DisplayBrightness=5
- ◀ pw /MANAGEMENT/UI.DisplayBrightness=5

7.4.15. Control Lock

Enable/disable the operation of the jog dial control knob.

Command and Response *#controllock*

- ▶ SET•/MANAGEMENT/UI.ControlLock=<parameter>
- ◀ pw•/MANAGEMENT/UI.ControlLock=<parameter>

Parameters

Parameter	Parameter description	Value	Value description
<parameter>	Lock/unlock of the jog dial control knob	0	The jog dial control knob is unlocked .
		1	The jog dial control knob is locked .
		2	The jog dial control knob is ForceLocked .

INFO: There is no difference between the 1 and 2 mode from the operation's point of view.

Example

- ▶ SET /MANAGEMENT/UI.ControlLock=1
- ◀ pw /MANAGEMENT/UI.ControlLock=1

7.4.16. Bootload Mode Setting

The device can be set to bootload (service / firmware update) mode. The AV signal transmission is terminated in this mode.

Command and Response *#bootload*

- ▶ CALL•/SYS:bootload()
- ◀ m0•/SYS:bootload=

Example

- ▶ CALL /SYS:bootload()
- ◀ m0 /SYS:bootload=

7.4.17. Restarting the Device

Calling the method results in the endpoints restarting – the connection with the remote device and the signal transmission will be terminated. After rebooting, the configuration settings are reloaded and the connection with the remote device is established again.

Command and Response #restart #reboot #reset

- ▶ CALL•/SYS:reset()
- ◀ mO•/SYS:reset=

Example

- ▶ CALL /SYS:reset()
- ◀ mO /SYS:reset=

7.4.18. Restore the Factory Default Settings

Command and Response #factory

- ▶ CALL•/SYS:factoryDefaults()
- ◀ mO•/SYS:factoryDefaults=

Example

- ▶ CALL /SYS:factoryDefaults()
- ◀ mO /SYS:factoryDefaults=

The device is restarted, current connections are terminated, and the default settings are restored. See the complete list in the [Factory Default Settings](#) section.

7.5. Video Port Settings - Transmitter Mode

INFO: Video port numbering can be found in the [Input/Output Port Numbering](#) section.

7.5.1. Query the Status of Source Port

Command and Response #portstatus

- ▶ GET•/MEDIA/VIDEO/XP.SourcePortStatus
- ◀ pr•/MEDIA/VIDEO/XP.SourcePortStatus=<in_status>;...;<in_status>

The response contains 5 ASCII characters for each port. The first character is reserved, the next four characters represent a 2-byte HEX code shows the current state of the input ports.

Example

- ▶ GET /MEDIA/VIDEO/XP.SourcePortStatus
- ◀ pr /MEDIA/VIDEO/XP.SourcePortStatus=T00AF;T00EF

Legend

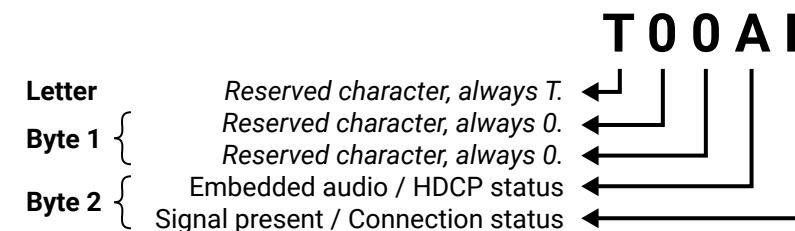

Example and Explanation (for input 1, T00AF)

	Byte 1				Byte 2			
	Character 2		Character 3		Character 4		Character 5	
	BIT 7-6	BIT 5-4	BIT 3-2	BIT 1-0	BIT 7-6	BIT 5-4	BIT 3-2	BIT 1-0
	Reserved	Reserved	Reserved	Reserved	Embedded audio status	HDCP status	Signal present status	Connection status
00	Unknown							
01	Reserved							
10	Reserved	Reserved	Reserved	Reserved	No embedded audio	Not encrypted	No signal	Not connected
11	Reserved	Reserved	Reserved	Reserved	Embedded audio presents	Encrypted	Signal presents	Connected

T	0		0		A		F	
Reserved	00	00	00	00	10	10	11	11
	Reserved	Reserved	Reserved	Reserved	No embedded audio	Not encrypted	Signal presents	Connected

The Most Common Received Port Status Responses

T000A	T	0		0		0		A	
	Reserved	00	00	00	00	00	00	00	10
	Reserved	Reserved	Reserved	Reserved	Reserved	Unknown	Unknown	No signal	Not connected

T00AA	T	0		0		A		A	
	Reserved	00	00	00	00	00	10	10	10
	Reserved	Reserved	Reserved	Reserved	Reserved	No embedded audio	Not encrypted	No signal	Not connected

T00AB	T	0		0		A		B	
	Reserved	00	00	00	00	00	10	10	10
	Reserved	Reserved	Reserved	Reserved	Reserved	No embedded audio	Not encrypted	No signal	Connected

T00AF	T	0		0		A		F	
	Reserved	00	00	00	00	00	10	10	11
	Reserved	Reserved	Reserved	Reserved	Reserved	No embedded audio	Not encrypted	Signal presents	Connected

T00EF	T	0		0		E		F	
	Reserved	00	00	00	00	00	11	10	11
	Reserved	Reserved	Reserved	Reserved	Reserved	Embedded audio presents	Not encrypted	Signal presents	Connected

T00BF	T	0		0		B		F	
	Reserved	00	00	00	00	00	10	11	11
	Reserved	Reserved	Reserved	Reserved	Reserved	No embedded audio	Encrypted	Signal presents	Connected

T00FF	T	0		0		F		F	
	Reserved	00	00	00	00	00	11	11	11
	Reserved	Reserved	Reserved	Reserved	Reserved	Embedded audio presents	Encrypted	Signal presents	Connected

7.5.2. Query the Status of Destination Port

Command and Response #portstatus

- ▶ GET*/MEDIA/VIDEO/XP.DestinationPortStatus
- ◀ pr*/MEDIA/VIDEO/XP.DestinationPortStatus=<out_status>;...;<out_status>

The response contains 5 ASCII characters for each port. The first character indicates the mute/lock state, the next 2-byte-long HEX code shows the current state of the output ports of the connected device.

Legend

See at the previous section.

Example

- ▶ GET /MEDIA/VIDEO/XP.DestinationPortStatus
- ◀ pr /MEDIA/VIDEO/XP.DestinationPortStatus=T00BF;T00EF

Example and Explanation (for output 1, T00BF)

T	0		0		B		F	
Reserved	00	00	00	00	10	11	11	11
	Reserved	Reserved	Reserved	Reserved	No embedded audio	Encrypted	Signal presents	Connected

7.5.3. Query the Video Crosspoint Setting

Displays the current crosspoint setting about which stream is transmitted to the output ports of the receiver.

Command and Response

- ▶ GET*/MEDIA/VIDEO/XP.DestinationConnectionList
- ◀ pr*/MEDIA/VIDEO/XP.DestinationConnectionList=<source>;<source>

Example

- ▶ GET /MEDIA/VIDEO/XP.DestinationConnectionList
- ◀ pr /MEDIA/VIDEO/XP.DestinationConnectionList=S1;S2

S1 stream from input 1 is connected to the D1 sink, S2 stream from input 2 is connected to the D2 sink.

7.5.4. Switching the Stream

Command and Response *#switch #crosspoint*

- ▶ CALL•/MEDIA/VIDEO/XP:switch(<source>:<destination>)
- ◀ mO•/MEDIA/VIDEO/XP:switch

Example

- ▶ CALL /MEDIA/VIDEO/XP:switch(S2:D1;S1:D2)
- ◀ mO /MEDIA/VIDEO/XP:switch

S2 stream is switched to D1 sink (O1 output port).

7.5.5. Switching a Stream to All Destinations

Command and Response *#switch #crosspoint*

- ▶ CALL•/MEDIA/VIDEO/XP:switchAll(<source>)
- ◀ mO•/MEDIA/VIDEO/XP:switchAll

Example

- ▶ CALL /MEDIA/VIDEO/XP:switchAll(S2)
- ◀ mO /MEDIA/VIDEO/XP:switchAll

S2 stream is switched to the D1 and D2 sinks.

7.5.6. Enable/Disable the Stream

Command and Response *#streamenable*

- ▶ SET•/MEDIA/VIDEO/<source>.Enabled=<logical_value>
- ◀ pw•/MEDIA/VIDEO/<source>.Enabled=<logical_value>

Parameters

Parameter	Parameter description	Value	Value description
<logical_value>	The stream is unmuted or muted.	true	The stream is enabled (unmuted).
		false	The stream is disabled (muted).

Example

- ▶ SET /MEDIA/VIDEO/S1.Enabled=true
- ◀ pw /MEDIA/VIDEO/S1.Enabled=true

7.5.7. Identify Stream

Calling the method generates 10 test colors on the display device for 10 seconds. The feature helps to identify the stream and the screen itself physically.

INFO: If the connected remote device is a multiviewer, the identify() command will effect the tile where the stream transmitted to.

Command and Response *#identifystream*

- ▶ CALL•/MEDIA/VIDEO/<source>.identify()
- ◀ mO•/MEDIA/VIDEO/<source>.identify

Example

- ▶ CALL /MEDIA/VIDEO/S1.identify()
- ◀ mO /MEDIA/VIDEO/S1.identify

Explanation



7.5.8. Resolution Setting

ATTENTION: The *ResolutionSetting* property can be set on the processed streams (S01 and S02) only, it cannot be applied on the transmitted native streams (S03 and S04). See the port numbering in the [Input/Output Port Numbering](#) section.

The resolution that is set here will be enforced only if the *ResolutionMode* is set to **Forced**. See the details about the Resolution Mode Setting in the next section.

Command and Response

- ▶ SET•/MEDIA/VIDEO/<source>.ResolutionSetting=<resolution>
- ◀ pw•/MEDIA/VIDEO/<source>.ResolutionSetting=<resolution>

Example

- ▶ SET /MEDIA/VIDEO/S2.ResolutionSetting=1600x1200p60
- ◀ pw /MEDIA/VIDEO/S2.ResolutionSetting=1600x1200p60

INFO: The entire list of available resolutions can be found in the [Resolutions of the Scaler](#) section.

7.5.9. Resolution Mode Setting

ATTENTION: The *ResolutionMode* property can be set on the processed streams (S01 and S02) only, it cannot be applied on the transmitted native streams (S03 and S04). See the port numbering in the [Input/Output Port Numbering](#) section.

Command and Response

- ▶ SET•/MEDIA/VIDEO/<source>.ResolutionMode=<resolution_mode>
- ◀ pw•/MEDIA/VIDEO/<source>.ResolutionMode=<resolution_mode>

Parameters

Parameter	Parameter description	Value	Value description
<resolution_mode>	Resolution mode setting	Pass	Pass-through mode - the original stream is transmitted to the receiver.
		Forced	The transmitter forces the resolution set in the <i>ResolutionSetting</i> for the stream and transmits it to the receiver.
		EdidBased	The transmitter forces the resolution that is read out from the EDID of the connected sink device of the RX / TRX. The resolution can be queried from a property - see the details in the Query the EDID Based Resolution (RX) or in the Query the EDID Based Resolution (TRX) sections.
		Tile	Choose this setting when the connected remote device is in Multiviewer operation mode. The applied resolution can be set in the <i>TileResolutionSetting</i> property, see the details in the Tile Resolution Setting section.

Example

- ▶ SET /MEDIA/VIDEO/S1.ResolutionMode=Forced
- ◀ pw /MEDIA/VIDEO/S1.ResolutionMode=Forced

#scaler #frc #multiviewer #tile

7.5.10. Scaler - Image Position Setting

ATTENTION: The *ImagePosition* property can be set on the processed streams (S01 and S02) only, it cannot be applied on the transmitted native streams (S03 and S04). See the port numbering in the [Input/Output Port Numbering](#) section.

The image position setting that is set here will be enforced only if the *ResolutionMode* is set to **Forced**. See the details about the Resolution Mode Setting in the previous section.

DIFFERENCE: The transmitter is built with scaler function on both HDMI input ports from **firmware version v2.4.1**. The scaler setting is not available on the HDMI in 2 (I2) port in case of previous firmware versions.

Command and Response

- ▶ SET•/MEDIA/VIDEO/<source>.ImagePosition=<image_position>
- ◀ pw•/MEDIA/VIDEO/<source>.ImagePosition=<image_position>

Parameters

The <image_position> can be set to **Center**, **Stretch** or **Fit**.

Example

- ▶ SET /MEDIA/VIDEO/S1.ImagePosition=Fit
- ◀ pw /MEDIA/VIDEO/S1.ImagePosition=Fit

7.5.11. Tile Resolution Setting

DIFFERENCE: The setting can be used only when the remote extender is in **Multiviewer** operation mode.

ATTENTION: The setting is available only when the [Resolution Mode Setting](#) is set to **Tile**.

If the connected remote device is a multiviewer, the output resolution can be set in the property. It **supports any custom resolution**, not requires to choose from the pre-installed resolutions of the UBEX endpoints. The frame rate remains the original stream's one.

Command and Response #tile #multiviewer

- ▶ SET•/MEDIA/VIDEO/<source>.TileResolutionSetting=<resolution>
- ◀ pw•/MEDIA/VIDEO/<source>.TileResolutionSetting=<resolution>

Example

- ▶ SET /MEDIA/VIDEO/S1.TileResolutionSetting=1600x1200p60
- ◀ pw /MEDIA/VIDEO/S1.TileResolutionSetting=1600x1200p60

7.5.12. Color Space Converter Setting

ATTENTION: The *ColorSpaceSetting* property can be set on the processed streams (S01 and S02) only, it cannot be applied on the transmitted native streams (S03 and S04). See the port numbering in the [Input/Output Port Numbering](#) section.

Command and Response *#csc #colorspace*

- ▶ SET•/MEDIA/VIDEO/<source>.ColorSpaceSetting=<color_space>
- ◀ pw•/MEDIA/VIDEO/<source>.ColorSpaceSetting=<color_space>

Parameters

Parameter	Parameter description	Value	Value description
<color_space>	Color space setting	Pass	Pass-through mode - the original color space of the stream is transmitted to the sink device.
		RGB	Forced RGB color space.
		YCbCr 4:4:4	Forced YCbCr 4:4:4 color space.
		YCbCr 4:2:2	Forced YCbCr 4:2:2 color space.

Example

- ▶ SET /MEDIA/VIDEO/S2.ColorSpaceSetting=YCbCr 4:4:4
- ◀ pw /MEDIA/VIDEO/S2.ColorSpaceSetting=YCbCr 4:4:4

7.5.13. Color Range Setting

ATTENTION: The *ColorRangeSetting* property can be set on the processed streams (S01 and S02) only, it cannot be applied on the transmitted native streams (S03 and S04). See the port numbering in the [Input/Output Port Numbering](#) section.

Command and Response *#colorrange*

- ▶ SET•/MEDIA/VIDEO/<source>.ColorRangeSetting=<color_range>
- ◀ pw•/MEDIA/VIDEO/<source>.ColorRangeSetting=<color_range>

Parameters

Parameter	Parameter description	Value	Value description
<color_range>	Color range setting	Pass	No color range conversion
		Full	Full color range
		Limited	Limited color range

Example

- ▶ SET /MEDIA/VIDEO/S1.ColorRangeSetting=Full
- ◀ pw /MEDIA/VIDEO/S1.ColorRangeSetting=Full

7.5.14. Color Depth Setting

ATTENTION: The *ColorDepthSetting* property can be set on the processed streams (S01 and S02) only, it cannot be applied on the transmitted native streams (S03 and S04). See the port numbering in the [Input/Output Port Numbering](#) section.

Command and Response *#colordepth*

- ▶ SET•/MEDIA/VIDEO/<source>.ColorDepthSetting=<color_depth>
- ◀ pw•/MEDIA/VIDEO/<source>.ColorDepthSetting=<color_depth>

Parameters

Parameter	Parameter description	Value	Value description
<color_depth>	Color depth setting	Pass	No color depth conversion
		8 bpc	Color depth is 8 bit/channel
		10 bpc	Color depth is 10 bit/channel
		12 bpc	Color depth is 12 bit/channel

Example

- ▶ SET /MEDIA/VIDEO/S1.ColorDepthSetting=8 bpc
- ◀ pw /MEDIA/VIDEO/S1.ColorDepthSetting=8 bpc

7.5.15. Query the Timing Mode

The query returns with the current status of the timing mode. See more details about it in the [Timing Modes](#) section.

DIFFERENCE: The timing mode can be changed in the output ports of the receiver/transceiver only.

Command and Response *#timingmode #freerun #sourcelocked*

- ▶ GET•/MEDIA/VIDEO/<source>.TimingMode
- ◀ pr•/MEDIA/VIDEO/<source>.TimingMode=<timing_mode>

Parameters

The <timing_mode> can be **Freerun** or **SourceLocked**.

Example

- ▶ GET /MEDIA/VIDEO/S1.TimingMode
- ◀ pr /MEDIA/VIDEO/S1.TimingMode=SourceLocked

7.5.16. HDCP Setting (Input Port)

HDCP capability can be enabled/disabled on the input ports, thus non-encrypted content can be enforced so that non-HDCP compliant displays can be used. See more information in the [HDCP Management](#) section.

Command and Response

- ▶ SET•/MEDIA/VIDEO/<in>.HdcpEnable=<logical_value>
- ◀ pw•/MEDIA/VIDEO/<in>.HdcpEnable=<logical_value>

Parameters

Parameter	Parameter description	Value	Value description
<logical_value>	HDCP enable/disable setting	true	HDCP authentication is enabled
		false	HDCP authentication is disabled

Example

- ▶ SET /MEDIA/VIDEO/I2.HdcpEnable=true
- ◀ pw /MEDIA/VIDEO/I2.HdcpEnable=true

7.5.17. HDCP Setting (Output Port)

HDCP capability can be set to Auto/Always on the output ports, thus non-encrypted content can be transmitted to a non-HDCP compliant display. See more information in the [HDCP Management](#) section.

Command and Response #hdcp

- ▶ SET•/MEDIA/VIDEO/<out>.HdcpMode=<HDCP_mode>
- ◀ pw•/MEDIA/VIDEO/<out>.HdcpMode=<HDCP_mode>

Parameters

Parameter	Parameter description	Value	Value description
<HDCP_mode>	HDCP mode	Auto	The level of the HDCP-encryption depends on the input.
		Always	The output ports set the maximum HDCP-encryption level that can be accepted by the connected sink device.
		AlwaysType1	The output ports always force HDCP 2.2 Type 1. If the sink device supports this HDCP-encryption level, the signal will be encrypted with HDCP 2.2 Type 0/1. The signal will be encrypted with HDCP 2.2 Type 1 when the source and the sink both support this HDCP-encryption level.

Example

- ▶ SET /MEDIA/VIDEO/O1.HdcpMode=AlwaysType1
- ◀ pw /MEDIA/VIDEO/O1.HdcpMode=AlwaysType1

7.6. Video Port Settings - Receiver Mode

INFO: Video port numbering can be found in the [Input/Output Port Numbering](#) section.

7.6.1. Query the Status of Source Port

Command and Response #portstatus

- ▶ GET•/MEDIA/VIDEO/XP.SourcePortStatus
- ◀ pr•/MEDIA/VIDEO/XP.SourcePortStatus=<out_status>;...;<out_status>

The response contains 5 ASCII characters for each port. The first character is reserved, the next four characters represent a 2-byte HEX code shows the current state of the input ports of the connected device.

Example

- ▶ GET /MEDIA/VIDEO/XP.SourcePortStatus
- ◀ pr /MEDIA/VIDEO/XP.SourcePortStatus=T00AF;T00EF

Legend

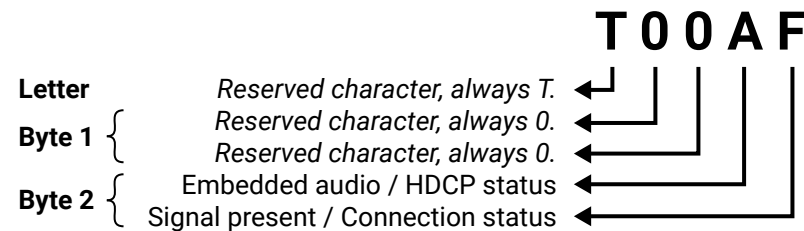

Example and Explanation (for input 1, T00AF)

	Byte 1				Byte 2			
	Character 2		Character 3		Character 4		Character 5	
	BIT 7-6	BIT 5-4	BIT 3-2	BIT 1-0	BIT 7-6	BIT 5-4	BIT 3-2	BIT 1-0
	Reserved	Reserved	Reserved	Reserved	Embedded audio status	HDCP status	Signal present status	Connection status
00	Reserved	Reserved	Reserved	Reserved	Unknown			
01					Reserved			
10					No embedded audio	Not encrypted	No signal	Not connected
11					Embedded audio presents	Encrypted	Signal presents	Connected

T	0		0		A		F	
Reserved	00	00	00	00	10	10	11	11
	Reserved	Reserved	Reserved	Reserved	No embedded audio	Not encrypted	Signal presents	Connected

The Most Common Received Port Status Responses

T000A	T	0		0		0		A	
	Reserved	00	00	00	00	00	00	10	10
	Reserved	Reserved	Reserved	Reserved	Reserved	Unknown	Unknown	No signal	Not connected

T00AA	T	0		0		A		A	
	Reserved	00	00	00	00	10	10	10	10
	Reserved	Reserved	Reserved	Reserved	Reserved	No embedded audio	Not encrypted	No signal	Not connected

T00AB	T	0		0		A		B	
	Reserved	00	00	00	00	10	10	10	11
	Reserved	Reserved	Reserved	Reserved	Reserved	No embedded audio	Not encrypted	No signal	Connected

T00AF	T	0		0		A		F	
	Reserved	00	00	00	00	10	10	11	11
	Reserved	Reserved	Reserved	Reserved	Reserved	No embedded audio	Not encrypted	Signal presents	Connected

T00EF	T	0		0		E		F	
	Reserved	00	00	00	00	11	10	11	11
	Reserved	Reserved	Reserved	Reserved	Reserved	Embedded audio presents	Not encrypted	Signal presents	Connected

T00BF	T	0		0		B		F	
	Reserved	00	00	00	00	10	11	11	11
	Reserved	Reserved	Reserved	Reserved	Reserved	No embedded audio	Encrypted	Signal presents	Connected

T00FF	T	0		0		F		F	
	Reserved	00	00	00	00	11	11	11	11
	Reserved	Reserved	Reserved	Reserved	Reserved	Embedded audio presents	Encrypted	Signal presents	Connected

7.6.2. Query the Status of Destination Port

Command and Response *#portstatus*

- ▶ GET•/MEDIA/VIDEO/XP.DestinationPortStatus
- ◀ pr•/MEDIA/VIDEO/XP.DestinationPortStatus=<out_status>;...;<out_status>

The response contains 5 ASCII characters for each port. The first character is reserved, the next four characters represent a 2-byte HEX code shows the current state of the output ports.

Example

- ▶ GET /MEDIA/VIDEO/XP.DestinationPortStatus
- ◀ pr /MEDIA/VIDEO/XP.DestinationPortStatus=T00BF;T00EF

Example and Explanation (for output 1, T00BF)

T	0		0		B		F	
Reserved	00	00	00	00	10	11	11	11
	Reserved	Reserved	Reserved	Reserved	No embedded audio	Encrypted	Signal presents	Connected

7.6.3. Query the Video Crosspoint Setting

Displays the current crosspoint setting about which stream is transmitted to the output ports of the receiver.

Command and Response

- ▶ GET•/MEDIA/VIDEO/XP.DestinationConnectionList
- ◀ pr•/MEDIA/VIDEO/XP.DestinationConnectionList=<source>;<source>

Example

- ▶ GET /MEDIA/VIDEO/XP.DestinationConnectionList
- ◀ pr /MEDIA/VIDEO/XP.DestinationConnectionList=S1;S2

S1 stream from input 1 is connected to the D1 sink, S2 stream from input 2 is connected to the D2 sink.

7.6.4. Switching the Stream

Command and Response *#switch #crosspoint*

- ▶ CALL•/MEDIA/VIDEO/XP:switch(<source>;<destination>)
- ◀ mO•/MEDIA/VIDEO/XP:switch

Example

- ▶ CALL /MEDIA/VIDEO/XP:switch(S2:D1;S1:D2)
- ◀ mO /MEDIA/VIDEO/XP:switch

S2 stream is switched to D1 sink (O1 output port).

7.6.5. Switching a Stream to All Destinations

Command and Response *#switch #crosspoint*

- ▶ CALL•/MEDIA/VIDEO/XP:switchAll(<source>)
- ◀ mO•/MEDIA/VIDEO/XP:switchAll

Example

- ▶ CALL /MEDIA/VIDEO/XP:switchAll(S2)
- ◀ mO /MEDIA/VIDEO/XP:switchAll

S2 stream is switched to the D1 and D2 sinks.

7.6.6. Disconnecting the Stream

Command and Response *#disconnect #crosspoint*

- ▶ CALL•/MEDIA/VIDEO/XP:switch(0:<destination>)
- ◀ mO•/MEDIA/VIDEO/XP:switch

Example

- ▶ CALL /MEDIA/VIDEO/XP:switch(0:D1)
- ◀ mO /MEDIA/VIDEO/XP:switch

D1 sink disconnected from the actual stream.

7.6.7. Enable/Disable the Stream

Command and Response *#streamenable*

- ▶ SET•/MEDIA/VIDEO/<destination>.Enabled=<logical_value>
- ◀ pw•/MEDIA/VIDEO/<destination>.Enabled=<logical_value>

Parameters

Parameter	Parameter description	Value	Value description
<logical_value>	The stream is unmuted or muted.	true	The stream is enabled (unmuted).
		false	The stream is disabled (muted).

Example

- ▶ SET /MEDIA/VIDEO/D1.Enabled=true
- ◀ pw /MEDIA/VIDEO/D1.Enabled=true

7.6.8. Resolution Mode Setting

Command and Response #scaler #frc

- ▶ SET•/MEDIA/VIDEO/<out>.ResolutionMode=<resolution_mode>
- ◀ pw•/MEDIA/VIDEO/<out>.ResolutionMode=<resolution_mode>

Parameters

Parameter	Parameter description	Value	Value description
<resolution_mode>	Resolution mode setting	Pass	Pass-through mode - the original stream is transmitted to the sink device.
		Forced	The receiver forces the resolution set in the <i>ResolutionSetting</i> for the stream and transmits it to the sink device.
		EdidBased	The receiver forces the resolution that is read out from the EDID of the connected sink device. The resolution can be queried from a property - see the details in the next section.

Example

- ▶ SET /MEDIA/VIDEO/O1.ResolutionMode=Forced
- ◀ pw /MEDIA/VIDEO/O1.ResolutionMode=Forced

7.6.9. Query the EDID Based Resolution

Command and Response

- ▶ GET•/MEDIA/VIDEO/<out>.EdidBasedResolution
- ◀ pr•/MEDIA/VIDEO/<out>.EdidBasedResolution=<resolution>

Example

- ▶ GET /MEDIA/VIDEO/O1.EdidBasedResolution
- ◀ pr /MEDIA/VIDEO/O1.EdidBasedResolution=3840x2160p60

7.6.10. Resolution Setting

The resolution that is set here will be enforced only if the *ResolutionMode* is set to **Forced**. See the details about the Resolution Mode Setting in the previous section.

Command and Response

- ▶ SET•/MEDIA/VIDEO/<out>.ResolutionSetting=<resolution>
- ◀ pw•/MEDIA/VIDEO/<out>.ResolutionSetting=<resolution>

Example

- ▶ SET /MEDIA/VIDEO/O2.ResolutionSetting=1600x1200p60
- ◀ pw /MEDIA/VIDEO/O2.ResolutionSetting=1600x1200p60
- INFO: The entire list of available resolutions can be found in the [Resolutions of the Scaler](#) section.

7.6.11. Scaler - Image Position Setting

The image position setting that is set here will be enforced only if the *ResolutionMode* is set to **Forced**. See the details about it in the [Resolution Mode Setting](#) section.

DIFFERENCE: The receiver is built with scaler function on both HDMI output ports from **firmware version v2.1.0**. The scaler setting is not available on the HDMI out 2 (O2) port in case of previous firmware versions.

Command and Response

- ▶ SET•/MEDIA/VIDEO/<out>.ImagePosition=<image_position>
- ◀ pw•/MEDIA/VIDEO/<out>.ImagePosition=<image_position>

Parameters

The <image_position> can be set to **Center**, **Stretch**, or **Fit**.

Example

- ▶ SET /MEDIA/VIDEO/O1.ImagePosition=Stretch
- ◀ pw /MEDIA/VIDEO/O1.ImagePosition=Stretch

#scaler #frc

7.6.12. Color Space Converter Setting

Command and Response *#csc #colorspace*

- ▶ SET•/MEDIA/VIDEO/<out>.ColorSpaceSetting=<color_space>
- ◀ pw•/MEDIA/VIDEO/<out>.ColorSpaceSetting=<color_space>

Parameters

Parameter	Parameter description	Value	Value description
<color_space>	Color space setting	Pass	Pass-through mode - the original color space of the stream is transmitted to the sink device.
		RGB	Forced RGB color space.
		YCbCr 4:4:4	Forced YCbCr 4:4:4 color space.
		YCbCr 4:2:2	Forced YCbCr 4:2:2 color space.

Example

- ▶ SET /MEDIA/VIDEO/O2.ColorSpaceSetting=YCbCr 4:4:4
- ◀ pw /MEDIA/VIDEO/O2.ColorSpaceSetting=YCbCr 4:4:4

7.6.13. Color Range Setting

Command and Response *#colorrange*

- ▶ SET•/MEDIA/VIDEO/<source>.ColorRangeSetting=<color_range>
- ◀ pw•/MEDIA/VIDEO/<source>.ColorRangeSetting=<color_range>

Parameters

Parameter	Parameter description	Value	Value description
<color_range>	Color range setting	Pass	No color range conversion
		Full	Full color range
		Limited	Limited color range

Example

- ▶ SET /MEDIA/VIDEO/S1.ColorRangeSetting=Full
- ◀ pw /MEDIA/VIDEO/S1.ColorRangeSetting=Full

7.6.14. Color Depth Setting

Command and Response *#colordepth*

- ▶ SET•/MEDIA/VIDEO/<out>.ColorDepthSetting=<color_depth>
- ◀ pw•/MEDIA/VIDEO/<out>.ColorDepthSetting=<color_depth>

Parameters

Parameter	Parameter description	Value	Value description
<color_depth>	Color depth setting	Pass	No color depth conversion
		8 bpc	Color depth is 8 bit/channel
		10 bpc	Color depth is 10 bit/channel
		12 bpc	Color depth is 12 bit/channel

Example

- ▶ SET /MEDIA/VIDEO/O1.ColorDepthSetting=8 bpc
- ◀ pw /MEDIA/VIDEO/O1.ColorDepthSetting=8 bpc

7.6.15. Query the Timing Mode

The query returns with the current status of the timing mode. See more details about it in the [Timing Modes](#) section.

Command and Response *#timingmode #freerun #sourcelocked*

- ▶ GET•/MEDIA/VIDEO/<out>.TimingMode
- ◀ pr•/MEDIA/VIDEO/<out>.TimingMode=<timing_mode>

Parameters

The <timing_mode> can be **Freerun** or **SourceLocked**.

Example

- ▶ GET /MEDIA/VIDEO/O1.TimingMode=SourceLocked
- ◀ pr /MEDIA/VIDEO/O1.TimingMode=SourceLocked

7.6.16. Timing Mode Setting

The timing mode is set with the following command. See more details about it in the [Timing Modes](#) section.

Command and Response *#timingmode #freerun #sourcelocked*

- ▶ SET•/MEDIA/VIDEO/<out>.TimingModeSetting=<timing_mode>
- ◀ pw•/MEDIA/VIDEO/<out>.TimingModeSetting=<timing_mode>

Parameters

The <timing_mode> can be set to **Freerun** or **SourceLocked**.

Example

- ▶ SET /MEDIA/VIDEO/02.TimingModeSetting=SourceLocked
- ◀ pw /MEDIA/VIDEO/02.TimingModeSetting=SourceLocked

7.6.17. Enable Signal Freeze

The signal freezes at the last video frame on the sink device (the sink may show a broken frame too).

Command and Response *#freeze*

- ▶ CALL•/MEDIA/VIDEO/<out>:freezeSignal()
- ◀ mO•/MEDIA/VIDEO/<out>:freezeSignal

Example

- ▶ CALL /MEDIA/VIDEO/01:freezeSignal()
- ◀ mO /MEDIA/VIDEO/01:freezeSignal

7.6.18. Disable Signal Freeze

The signal freezes at the last video frame on the sink device (the sink may show a broken frame too).

Command and Response *#freeze*

- ▶ CALL•/MEDIA/VIDEO/<out>:unfreezeSignal()
- ◀ mO•/MEDIA/VIDEO/<out>:unfreezeSignal

Example

- ▶ CALL /MEDIA/VIDEO/01:unfreezeSignal()
- ◀ mO /MEDIA/VIDEO/01:unfreezeSignal

7.6.19. No Sync Screen (Test Pattern) Mode

The No sync screen feature generates an image that can be displayed when there is no incoming signal on the port. The following method turns on or off the Test Pattern function.

Command and Response *#testpattern #nosyncscreen*

- ▶ SET•/MEDIA/VIDEO/<out>.NoSyncMode=<nosync_mode>
- ◀ pw•/MEDIA/VIDEO/<out>. NoSyncMode=<nosync_mode>

Parameters

Parameter	Parameter description	Value	Value description
<nosync_mode>	Test pattern mode setting	AlwaysOff	The test pattern is not displayed on the output.
		NoSignal	The test pattern is displayed if there is no video is received on the output port.
		AlwaysOn	The test pattern is displayed on the output even if there is an incoming signal.
		Freeze	The signal freezes at the last video frame on the sink device (the sink may show a broken frame too).

Example

- ▶ SET /MEDIA/VIDEO/01.NoSyncMode=NoSignal
- ◀ pw /MEDIA/VIDEO/01.NoSyncMode=NoSignal

7.6.20. No Sync Screen (Test Pattern) Color Setting

The No sync screen feature generates an image that can be displayed when there is no incoming signal on the port. The following method sets the displayed color defined in RGB code.

Command and Response

- ▶ SET•/MEDIA/VIDEO/<out>.NoSyncColor=<RGB_code>
- ◀ pw•/MEDIA/VIDEO/<out>. NoSyncColor=<RGB_code>

Example

- ▶ SET /MEDIA/VIDEO/01.NoSyncColor=128,128,128
- ◀ pw /MEDIA/VIDEO/01.NoSyncColor=128,128,128

7.6.21. HDCP Setting (Input Port)

HDCP capability can be enabled/disabled on the input ports, thus non-encrypted content can be enforced so that non-HDCP compliant displays can be used. See more information in the [HDCP Management](#) section.

Command and Response

- ▶ SET•/MEDIA/VIDEO/<in>.HdcpEnable=<logical_value>
- ◀ pw•/MEDIA/VIDEO/<in>.HdcpEnable=<logical_value>

Parameters

Parameter	Parameter description	Value	Value description
<logical_value>	HDCP enable/disable setting	true	HDCP authentication is enabled
		false	HDCP authentication is disabled

Example

- ▶ SET /MEDIA/VIDEO/I2.HdcpEnable=true
- ◀ pw /MEDIA/VIDEO/I2.HdcpEnable=true

7.6.22. HDCP Setting (Output Port)

HDCP capability can be set to Auto/Always on the output ports, thus non-encrypted content can be transmitted to a non-HDCP compliant display. See more information in the [HDCP Management](#) section.

Command and Response #hdcp

- ▶ SET•/MEDIA/VIDEO/<out>.HdcpMode=<HDCP_mode>
- ◀ pw•/MEDIA/VIDEO/<out>.HdcpMode=<HDCP_mode>

Parameters

Parameter	Parameter description	Value	Value description
<HDCP_mode>	HDCP mode	Auto	The level of the HDCP-encryption depends on the input.
		Always	The output ports set the maximum HDCP-encryption level that can be accepted by the connected sink device.
		AlwaysType1	The output ports always force HDCP 2.2 Type 1. If the sink device supports this HDCP-encryption level, the signal will be encrypted with HDCP 2.2 Type 0/1. The signal will be encrypted with HDCP 2.2 Type 1 when the source and the sink both support this HDCP-encryption level.

Example

- ▶ SET /MEDIA/VIDEO/O1.HdcpMode=AlwaysType1
- ◀ pw /MEDIA/VIDEO/O1.HdcpMode=AlwaysType1

7.6.23. Identify Display

Calling the method generates 10 test colors on the display device for 10 seconds. The feature helps to identify the stream and the screen itself physically.

Command and Response #identifydisplay

- ▶ CALL•/MEDIA/VIDEO/<out>:identify()
- ◀ mO•/MEDIA/VIDEO/<out>:identify

Example

- ▶ CALL /MEDIA/VIDEO/O1:identify()
- ◀ mO /MEDIA/VIDEO/O1:identify

Explanation



7.6.24. Query the Source MUX Options

The source multiplexer (**Source MUX**) makes routing several different source signals to the HDMI output ports available. See more details about this function in the [Receiver Mode](#) section.

The query responds the available source signals for the selected output port.

Command and Response #mux #sourcemux

- ▶ GET•/MEDIA/VIDEO/<out>.SourceMuxOptions
- ◀ pr•/MEDIA/VIDEO/<out>.SourceMuxOptions=<mux_options>

Parameters

Parameter	Parameter description	Value	Value description
<mux_options>	The available sources for the output port	D1	The D1 destination stream is selectable for the output port (only for O1).
		D2	The D2 destination stream is selectable for the output port (only for O2).
		I1	The stream of the I1 local input port is selectable for the output port (only for O1).
		I2	The stream of the I2 local input port is selectable for the output port (only for O2).
		O1	The copy of the stream of O1 output port is selectable for the output port (only for O2).

Example

- ▶ GET /MEDIA/VIDEO/O2.SourceMuxOptions
- ◀ pr /MEDIA/VIDEO/O2.SourceMuxOptions=D2;I2;O1

7.6.25. Source MUX Setting

The source multiplexer (**Source MUX**) makes routing several different source signals to the HDMI output ports available. See more details about this function in the [Receiver Mode](#) section.

The command sets the source signal for the output port. Query the available options with the command described in the previous section.

Command and Response #mux #sourcemux

- ▶ SET•/MEDIA/VIDEO/<out>.SourceMux=<destination|in|out>
- ◀ pw•/MEDIA/VIDEO/<out>.SourceMux=<destination|in|out>

Example

- ▶ SET /MEDIA/VIDEO/O1.SourceMux=I1
- ◀ pw /MEDIA/VIDEO/O1.SourceMux=I1

7.7. Video Port Settings - Transceiver Mode

INFO: Video port numbering can be found in the [Input/Output Port Numbering](#) section.

7.7.1. Query the Status of Source Port

Command and Response #poststatus

- ▶ GET•/MEDIA/VIDEO/XP.SourcePortStatus
- ◀ pr•/MEDIA/VIDEO/XP.SourcePortStatus=<in_status>;...;<in_status>

The response contains 5 ASCII characters for each port. The first character is reserved, the next four characters represent a 2-byte HEX code shows the current state of the input ports.

Example

- ▶ GET /MEDIA/VIDEO/XP.SourcePortStatus
- ◀ pr /MEDIA/VIDEO/XP.SourcePortStatus=T00AF;T00EF

Legend

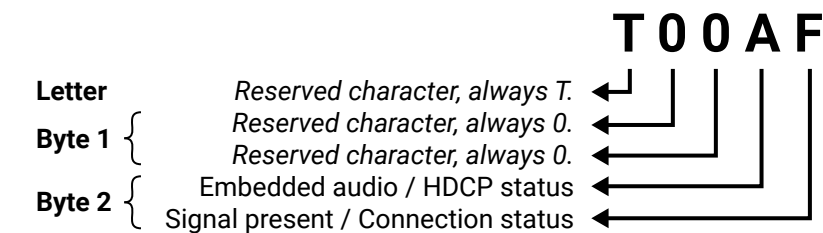

Example and Explanation (for input 1, T00AF)

	Byte 1				Byte 2			
	Character 2		Character 3		Character 4		Character 5	
	BIT 7-6	BIT 5-4	BIT 3-2	BIT 1-0	BIT 7-6	BIT 5-4	BIT 3-2	BIT 1-0
	Reserved	Reserved	Reserved	Reserved	Embedded audio status	HDCP status	Signal present status	Connection status
00	Reserved	Reserved	Reserved	Reserved	Unknown			
01					Reserved			
10					No embedded audio	Not encrypted	No signal	Not connected
11					Embedded audio presents	Encrypted	Signal presents	Connected

T	0		0		A		F	
Reserved	00	00	00	00	10	10	11	11
	Reserved	Reserved	Reserved	Reserved	No embedded audio	Not encrypted	Signal presents	Connected

The Most Common Received Port Status Responses

T000A	T	0		0		0		A	
	Reserved	00	00	00	00	00	00	00	10
	Reserved	Reserved	Reserved	Reserved	Reserved	Unknown	Unknown	No signal	Not connected

T00AA	T	0		0		A		A	
	Reserved	00	00	00	00	00	10	10	10
	Reserved	Reserved	Reserved	Reserved	Reserved	No embedded audio	Not encrypted	No signal	Not connected

T00AB	T	0		0		A		B	
	Reserved	00	00	00	00	00	10	10	10
	Reserved	Reserved	Reserved	Reserved	Reserved	No embedded audio	Not encrypted	No signal	Connected

T00AF	T	0		0		A		F	
	Reserved	00	00	00	00	00	10	10	11
	Reserved	Reserved	Reserved	Reserved	Reserved	No embedded audio	Not encrypted	Signal presents	Connected

T00EF	T	0		0		E		F	
	Reserved	00	00	00	00	00	11	10	11
	Reserved	Reserved	Reserved	Reserved	Reserved	Embedded audio presents	Not encrypted	Signal presents	Connected

T00BF	T	0		0		B		F	
	Reserved	00	00	00	00	00	10	11	11
	Reserved	Reserved	Reserved	Reserved	Reserved	No embedded audio	Encrypted	Signal presents	Connected

T00FF	T	0		0		F		F	
	Reserved	00	00	00	00	00	11	11	11
	Reserved	Reserved	Reserved	Reserved	Reserved	Embedded audio presents	Encrypted	Signal presents	Connected

7.7.2. Query the Status of Destination Port

Command and Response #poststatus

- ▶ GET*/MEDIA/VIDEO/XP.DestinationPortStatus
- ◀ pr*/MEDIA/VIDEO/XP.DestinationPortStatus=<out_status>;...;<out_status>

The response contains 5 ASCII characters for each port. The first character indicates the mute/lock state, the next 2-byte-long HEX code shows the current state of the output ports.

Legend

See at the previous section.

Example

- ▶ GET /MEDIA/VIDEO/XP.DestinationPortStatus
- ◀ pr /MEDIA/VIDEO/XP.DestinationPortStatus=T00BF;T00EF

Example and Explanation (for output 1, T00BF)

T	0		0		B		F	
Reserved	00	00	00	00	10	11	11	11
	Reserved	Reserved	Reserved	Reserved	No embedded audio	Encrypted	Signal presents	Connected

7.7.3. Switching the Stream

Command and Response #switch #crosspoint

- ▶ CALL*/MEDIA/VIDEO/XP:switch(<source>:<destination>)
- ◀ m0*/MEDIA/VIDEO/XP:switch

Example

- ▶ CALL /MEDIA/VIDEO/XP:switch(S2:D1)
- ◀ m0 /MEDIA/VIDEO/XP:switch

S2 stream is switched to D1 sink (O1 output port).

7.7.4. Disconnecting the Stream

Command and Response *#disconnect #crosspoint*

- ▶ CALL•/MEDIA/VIDEO/XP:switch(0:<destination>)
- ◀ mO•/MEDIA/VIDEO/XP:switch

Example

- ▶ CALL /MEDIA/VIDEO/XP:switch(0:D1)
- ◀ mO /MEDIA/VIDEO/XP:switch

D1 sink disconnected from the actual stream.

7.7.5. Enable/Disable the Stream

Command and Response *#streamenable*

- ▶ SET•/MEDIA/VIDEO/<source>.Enabled=<logical_value>
- ◀ pw•/MEDIA/VIDEO/<source>.Enabled=<logical_value>

Parameters

Parameter	Parameter description	Value	Value description
<logical_value>	The stream is unmuted or muted.	true	The stream is enabled (unmuted).
		false	The stream is disabled (muted).

Example

- ▶ SET /MEDIA/VIDEO/S1.Enabled=true
- ◀ pw /MEDIA/VIDEO/S1.Enabled=true

7.7.6. Identify Stream / Identify Display

Calling the method generates 10 test colors on the display device for 10 seconds. The feature helps to identify the stream and the screen itself physically.

INFO: If the connected remote device is a multiviewer, the identify() command will effect the tile where the stream transmitted to.

Command and Response *#identifystream #identifydisplay*

- ▶ CALL•/MEDIA/VIDEO/<source|out>.identify()
- ◀ mO•/MEDIA/VIDEO/<source|out>.identify

Example

- ▶ CALL /MEDIA/VIDEO/S1.identify()
- ◀ mO /MEDIA/VIDEO/S1.identify

Explanation



7.7.7. Resolution Mode Setting - Input Side

Command and Response

- ▶ SET•/MEDIA/VIDEO/<source>.ResolutionMode=<resolution_mode>
- ◀ pw•/MEDIA/VIDEO/<source>.ResolutionMode=<resolution_mode>

Parameters

Parameter	Parameter description	Value	Value description
<resolution_mode>	Resolution mode setting	Pass	Pass-through mode - the original stream is transmitted.
		Forced	The transceiver forces the resolution set in the <i>ResolutionSetting</i> for the stream.

Example

- ▶ SET /MEDIA/VIDEO/S1.ResolutionMode=Forced
- ◀ pw /MEDIA/VIDEO/S1.ResolutionMode=Forced

7.7.8. Resolution Mode Setting - Output Side

Command and Response

- ▶ SET•/MEDIA/VIDEO/<out>.ResolutionMode=<resolution_mode>
- ◀ pw•/MEDIA/VIDEO/<out>.ResolutionMode=<resolution_mode>

Parameters

Parameter	Parameter description	Value	Value description
<resolution_mode>	Resolution mode setting	Pass	Pass-through mode - the original stream is transmitted to the sink device.
		Forced	The transceiver forces the resolution set in the <i>ResolutionSetting</i> for the stream and transmits it to the sink device.
		EdidBased	The transceiver forces the resolution that is read out from the EDID of the connected sink device. The resolution can be queried from a property - see the details in the next section.
		Tile	Choose this setting when the connected remote device is in Multiviewer operation mode. The applied resolution can be set in the <i>TileResolutionSetting</i> property, see the details in the Tile Resolution Setting section.

Example

- ▶ SET /MEDIA/VIDEO/O1.ResolutionMode=EdidBased
- ◀ pw /MEDIA/VIDEO/O1.ResolutionMode=EdidBased

7.7.9. Query the EDID Based Resolution

Command and Response

- ▶ GET•/MEDIA/VIDEO/<out>.EdidBasedResolution
- ◀ pr•/MEDIA/VIDEO/<out>.EdidBasedResolution=<resolution>

Example

- ▶ GET /MEDIA/VIDEO/O1.EdidBasedResolution
- ◀ pr /MEDIA/VIDEO/O1.EdidBasedResolution=3840x2160p60

#scaler #frc

7.7.10. Resolution Setting

The resolution that is set here will be enforced only if the *ResolutionMode* is set to **Forced**. See the details about the Resolution Mode Setting in the previous sections.

Command and Response

- ▶ SET•/MEDIA/VIDEO/<source|out>.ResolutionSetting=<resolution>
- ◀ pw•/MEDIA/VIDEO/<source|out>.ResolutionSetting=<resolution>

Example

- ▶ SET /MEDIA/VIDEO/O1.ResolutionSetting=1600x1200p60
- ◀ pw /MEDIA/VIDEO/O1.ResolutionSetting=1600x1200p60
- INFO: The entire list of available resolutions can be found in the [Resolutions of the Scaler](#) section.

7.7.11. Scaler - Image Position Setting

The image position setting that is set here will be enforced only if the *ResolutionMode* is set to **Forced**.

DIFFERENCE: The transceiver is built with scaler function on HDMI input 2 port from firmware version v2.1.0. The scaler setting is not available in case of previous firmware versions.

Command and Response

- ▶ SET•/MEDIA/VIDEO/<source|out>.ImagePosition=<image_position>
- ◀ pw•/MEDIA/VIDEO/<source|out>.ImagePosition=<image_position>

Parameters

The <image_position> can be set to **Center**, **Stretch**, or **Fit**.

Example

- ▶ SET /MEDIA/VIDEO/O1.ImagePosition=Stretch
- ◀ pw /MEDIA/VIDEO/O1.ImagePosition=Stretch

#scaler #frc

7.7.12. Tile Resolution Setting

DIFFERENCE: The setting can be used only when the remote extender is in **Multiviewer** operation mode.

ATTENTION: The setting is available only when the [Resolution Mode Setting](#) is set to **Tile**.

If the connected remote device is a multiviewer, the output resolution can be set in the property. It **supports any custom resolution**, not requires to choose from the pre-installed resolutions of the UBEX endpoints. The frame rate remains the original stream's one.

Command and Response #tile #multiviewer

- ▶ SET•/MEDIA/VIDEO/<source>.TileResolutionSetting=<resolution>
- ◀ pw•/MEDIA/VIDEO/<source>.TileResolutionSetting=<resolution>

Example

- ▶ SET /MEDIA/VIDEO/S1.TileResolutionSetting=1600x1200p60
- ◀ pw /MEDIA/VIDEO/S1.TileResolutionSetting=1600x1200p60

7.7.13. Color Space Converter Setting

Command and Response #csc #colorspace

- ▶ SET•/MEDIA/VIDEO/<source|out>.ColorSpaceSetting=<color_space>
- ◀ pw•/MEDIA/VIDEO/<source|out>.ColorSpaceSetting=<color_space>

Parameters

Parameter	Parameter description	Value	Value description
<color_space>	Color space setting	Pass	Pass-through mode - the original color space of the stream is transmitted to the sink device.
		RGB	Forced RGB color space.
		YCbCr 4:4:4	Forced YCbCr 4:4:4 color space.
		YCbCr 4:2:2	Forced YCbCr 4:2:2 color space.

Example

- ▶ SET /MEDIA/VIDEO/O1.ColorSpaceSetting=YCbCr 4:4:4
- ◀ pw /MEDIA/VIDEO/O1.ColorSpaceSetting=YCbCr 4:4:4

7.7.14. Color Range Setting

Command and Response #colorrange

- ▶ SET•/MEDIA/VIDEO/<source|out>.ColorRangeSetting=<color_range>
- ◀ pw•/MEDIA/VIDEO/<source|out>.ColorRangeSetting=<color_range>

Parameters

Parameter	Parameter description	Value	Value description
<color_range>	Color range setting	Pass	No color range conversion
		Full	Full color range
		Limited	Limited color range

Example

- ▶ SET /MEDIA/VIDEO/S1.ColorRangeSetting=Limited
- ◀ pw /MEDIA/VIDEO/S1.ColorRangeSetting=Limited

7.7.15. Color Depth Setting

Command and Response #colordepth

- ▶ SET•/MEDIA/VIDEO/<source|out>.ColorDepthSetting=<color_depth>
- ◀ pw•/MEDIA/VIDEO/<source|out>.ColorDepthSetting=<color_depth>

Parameters

Parameter	Parameter description	Value	Value description
<color_depth>	Color depth setting	Pass	No color depth conversion
		8 bpc	Color depth is 8 bit/channel
		10 bpc	Color depth is 10 bit/channel
		12 bpc	Color depth is 12 bit/channel

Example

- ▶ SET /MEDIA/VIDEO/O1.ColorDepthSetting=8 bpc
- ◀ pw /MEDIA/VIDEO/O1.ColorDepthSetting=8 bpc

7.7.16. Query the Timing Mode

The query returns with the current status of the timing mode. See more details about it in the [Timing Modes](#) section.

ATTENTION: The timing mode can be changed in the receiver only. See the related LW3 protocol command in the [Timing Mode Setting](#) section.

Command and Response *#timingmode #freerun #sourcelocked*

- ▶ GET•/MEDIA/VIDEO/<source|out>.TimingMode
- ◀ pr•/MEDIA/VIDEO/<source|out>.TimingMode=<timing_mode>

Parameters

The <timing_mode> can be **Freerun** or **SourceLocked**.

Example

- ▶ GET /MEDIA/VIDEO/S1.TimingMode
- ◀ pr /MEDIA/VIDEO/S1.TimingMode=SourceLocked

7.7.17. Timing Mode Setting

The timing mode is set with the following command. See more details about it in the [Timing Modes](#) section.

INFO: The timing mode setting is available for the stream of the HDMI output 1 port only.

Command and Response *#timingmode #freerun #sourcelocked*

- ▶ SET•/MEDIA/VIDEO/<out>.TimingModeSetting=<timing_mode>
- ◀ pw•/MEDIA/VIDEO/<out>.TimingModeSetting=<timing_mode>

Parameters

The <timing_mode> can be set to **Freerun** or **SourceLocked**.

Example

- ▶ SET /MEDIA/VIDEO/O1.TimingModeSetting=SourceLocked
- ◀ pw /MEDIA/VIDEO/O1.TimingModeSetting=SourceLocked

7.7.18. Enable Signal Freeze

The signal freezes at the last video frame on the sink device (the sink may show a broken frame too).

Command and Response *#freeze*

- ▶ CALL•/MEDIA/VIDEO/<out>:freezeSignal()
- ◀ mO•/MEDIA/VIDEO/<out>:freezeSignal

Example

- ▶ CALL /MEDIA/VIDEO/O1:freezeSignal()
- ◀ mO /MEDIA/VIDEO/O1:freezeSignal

7.7.19. Disable Signal Freeze

The signal freezes at the last video frame on the sink device (the sink may show a broken frame too).

Command and Response *#freeze*

- ▶ CALL•/MEDIA/VIDEO/<out>:unfreezeSignal()
- ◀ mO•/MEDIA/VIDEO/<out>:unfreezeSignal

Example

- ▶ CALL /MEDIA/VIDEO/O1:unfreezeSignal()
- ◀ mO /MEDIA/VIDEO/O1:unfreezeSignal

7.7.20. No Sync Screen (Test Pattern) Mode

The No sync screen feature generates an image that can be displayed when there is no incoming signal on the port. The following method turns on or off the Test Pattern function.

INFO: The no sync screen setting is available for the stream of the HDMI output 1 port only.

Command and Response #testpattern #nosyncscreen

- ▶ SET•/MEDIA/VIDEO/<out>.NoSyncMode=<nosync_mode>
- ◀ pw•/MEDIA/VIDEO/<out>.NoSyncMode=<nosync_mode>

Parameters

Parameter	Parameter description	Value	Value description
<nosync_mode>	Test pattern mode setting	AlwaysOff	The test pattern is not displayed on the output.
		NoSignal	The test pattern is displayed if there is no video is received on the output port.
		AlwaysOn	The test pattern is displayed on the output even if there is an incoming signal.
		Freeze	The signal freezes at the last video frame on the sink device (the sink may show a broken frame too).

Example

- ▶ SET /MEDIA/VIDEO/01.NoSyncMode=NoSignal
- ◀ pw /MEDIA/VIDEO/01.NoSyncMode=NoSignal

7.7.21. No Sync Screen (Test Pattern) Color Setting

The No sync screen feature generates an image that can be displayed when there is no incoming signal on the port. The following method sets the displayed color defined in RGB code.

INFO: The no sync screen setting is available for the stream of the HDMI output 1 port only.

Command and Response

- ▶ SET•/MEDIA/VIDEO/<out>.NoSyncColor=<RGB_code>
- ◀ pw•/MEDIA/VIDEO/<out>.NoSyncColor=<RGB_code>

Example

- ▶ SET /MEDIA/VIDEO/01.NoSyncColor=128,128,128
- ◀ pw /MEDIA/VIDEO/01.NoSyncColor=128,128,128

7.7.22. HDCP Setting (Input Port)

HDCP capability can be enabled/disabled on the input ports, thus non-encrypted content can be enforced so that non-HDCP compliant displays can be used. See more information in the [HDCP Management](#) section.

Command and Response #hdcp

- ▶ SET•/MEDIA/VIDEO/<in>.HdcpEnable=<logical_value>
- ◀ pw•/MEDIA/VIDEO/<in>.HdcpEnable=<logical_value>

Parameters

Parameter	Parameter description	Value	Value description
<logical_value>	HDCP enable/disable setting	true	HDCP authentication is enabled
		false	HDCP authentication is disabled

Example

- ▶ SET /MEDIA/VIDEO/I2.HdcpEnable=true
- ◀ pw /MEDIA/VIDEO/I2.HdcpEnable=true

7.7.23. HDCP Setting (Output Port)

HDCP capability can be set to Auto/Always on the output ports, thus non-encrypted content can be transmitted to a non-HDCP compliant display. See more information in the [HDCP Management](#) section.

Command and Response

- ▶ SET•/MEDIA/VIDEO/<out>.HdcpMode=<HDCP_mode>
- ◀ pw•/MEDIA/VIDEO/<out>.HdcpMode=<HDCP_mode>

Parameters

Parameter	Parameter description	Value	Value description
<HDCP_mode>	HDCP mode	Auto	The level of the HDCP-encryption depends on the input.
		Always	The output ports set the maximum HDCP-encryption level that can be accepted by the connected sink device.
		AlwaysType1	The output ports always force HDCP 2.2 Type 1. If the sink device supports this HDCP-encryption level, the signal will be encrypted with HDCP 2.2 Type 0/1. The signal will be encrypted with HDCP 2.2 Type 1 when the source and the sink both support this HDCP-encryption level.

Example

- ▶ SET /MEDIA/VIDEO/01.HdcpMode=Always
- ◀ pw /MEDIA/VIDEO/01.HdcpMode=Always

7.7.24. Querying the Source MUX Options

The source multiplexer (**Source MUX**) makes routing several different source signals to the HDMI output ports available. See more details about this function in the [Transceiver Mode](#) section.

The query responds the available source signals for the selected output port.

Command and Response *#mux #sourcemux*

- ▶ GET*/MEDIA/VIDEO/<out>.SourceMuxOptions
- ◀ pr*/MEDIA/VIDEO/<out>.SourceMuxOptions=<mux_options>

Parameters

Parameter	Parameter description	Value	Value description
<mux_options>	The available sources for the output port	I2	The stream of the I2 local input port is selectable for the output port (only for O2).
		O1	The copy of the stream of O1 output port is selectable for the output port (only for O2).

Example

- ▶ GET /MEDIA/VIDEO/O2.SourceMuxOptions
- ◀ pr /MEDIA/VIDEO/O2.SourceMuxOptions=I2;O1

7.7.25. Source MUX Setting

The source multiplexer (**Source MUX**) makes routing several different source signals to the HDMI output ports available. See more details about this function in the [Transceiver Mode](#) section.

The command sets the source signal for the output port. Query the available options with the command described in the previous section.

Command and Response *#mux #sourcemux*

- ▶ SET*/MEDIA/VIDEO/<out>.SourceMux=<in|out>
- ◀ pw*/MEDIA/VIDEO/<out>.SourceMux=<in|out>

Example

- ▶ SET /MEDIA/VIDEO/O2.SourceMux=O1
- ◀ pw /MEDIA/VIDEO/O2.SourceMux=O1

7.8. Multiviewer Configuration

Learn more details about the functions and rules of the multiviewer mode in the [Multiviewer Mode](#) section.

#multiviewer #rxmv

7.8.1. Setting the Resolution of the Canvas

The *ResolutionMode* is fixed to **Forced** and cannot be changed in case of multiviewer mode. This setting is equal to the resolution of the sink device and the resolution of the **canvas** as well. *#canvas*

Command and Response

- ▶ SET*/MEDIA/VIDEO/<out>.ResolutionSetting=<resolution>
- ◀ pw*/MEDIA/VIDEO/<out>.ResolutionSetting=<resolution>

Example

- ▶ SET /MEDIA/VIDEO/O1.ResolutionSetting=3840x2160p60
- ◀ pw /MEDIA/VIDEO/O1.ResolutionSetting=3840x2160p60

INFO: The entire list of available resolutions can be found in the [Resolutions of the Scaler](#) section.

7.8.2. Enabling/Disabling the Tile

The tile in the canvas can be enabled or disabled.

There are four tile properties (T1; T2; T3; T4) under the O1 port, but in Extender application, we usually use only 2 tiles (T1 and T2).

#tile

Command and Response

- ▶ SET*/MEDIA/VIDEO/<out>/<tile>.Enabled=<logical_value>
- ◀ pw*/MEDIA/VIDEO/<out>/<tile>.Enabled=<logical_value>

Parameters

Parameter	Parameter description	Value	Value description
<logical_value>	The stream is unmuted or muted.	true	The stream is enabled (unmuted).
		false	The stream is disabled (muted).
<tile>	Tile ID	T1	The ID of Tile #1.
		T2	The ID of Tile #2.
		T3	The ID of Tile #3.
		T4	The ID of Tile #4.

Example

- ▶ SET /MEDIA/VIDEO/O1/T2.Enabled=false
- ◀ pw /MEDIA/VIDEO/O1/T2.Enabled=false

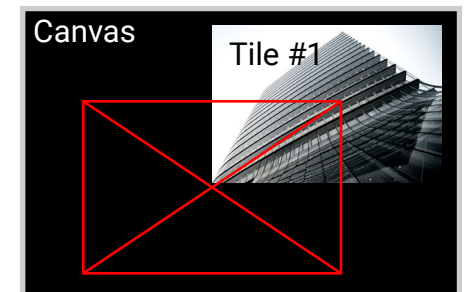

7.8.3. Tile Position Setting

The position of the tile inside the canvas can be set with the property. The top left corner of the tile is the starter pixel, the required parameters are the horizontal and vertical pixels.

ATTENTION: In case of picture-in-picture mode, the position of the background tile shall be 0, 0.

ATTENTION: Tiles must be placed within the canvas area, extending beyond the canvas is not supported.



Command and Response

- ▶ SET•/MEDIA/VIDEO/<out>/<tile>.Position=<horizontal_pixels>, <vertical_pixels>
- ◀ pw•/MEDIA/VIDEO/<out>/<tile>.Position=<horizontal_pixels>, <vertical_pixels>

Parameters

Parameter	Parameter description	Value	Value description
<tile>	Tile ID	T1	The ID of Tile #1.
		T2	The ID of Tile #2.
		T3	The ID of Tile #3.
		T4	The ID of Tile #4.

Example

- ▶ SET /MEDIA/VIDEO/O1/T2.Position=200, 300
- ◀ pw /MEDIA/VIDEO/O1/T2.Position=200, 300

7.8.4. Tile Size Setting

The resolution of the tile inside the canvas can be set with the property. #tile

ATTENTION: The tile size and the resolution of the input stream must be the same. See the scaler resolution setting on the transmitter side in the [Tile Resolution Setting](#) section.

ATTENTION: Tiles must be placed within the canvas area, extending beyond the canvas is not supported.

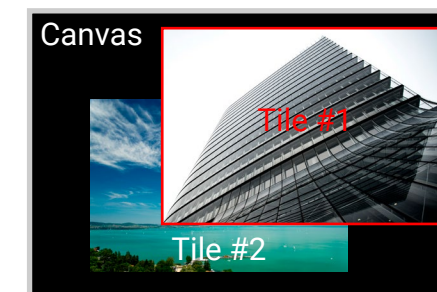

Command and Response

- ▶ SET•/MEDIA/VIDEO/<out>/<tile>.Size=<horizontal_pixels>x<vertical_pixels>
- ◀ pw•/MEDIA/VIDEO/<out>/<tile>.Size=<horizontal_pixels>x<vertical_pixels>

Parameters

Parameter	Parameter description	Value	Value description
<tile>	Tile ID	T1	The ID of Tile #1.
		T2	The ID of Tile #2.
		T3	The ID of Tile #3.
		T4	The ID of Tile #4.

Example

- ▶ SET /MEDIA/VIDEO/O1/T2.Size=1280x720
- ◀ pw /MEDIA/VIDEO/O1/T2.Size=1280x720

7.8.5. Layer Order Setting

The command is for re-prioritization the tile layouts that can be used in case of the tiles overlap each other. The priority of the tiles determines which is in front.



Command and Response

- ▶ SET•/MEDIA/VIDEO/<out>.LayerOrder=<tile_ID>;<tile_ID>;<tile_ID>;<tile_ID>
- ◀ pw•/MEDIA/VIDEO/<out>.LayerOrder=<tile_ID>;<tile_ID>;<tile_ID>;<tile_ID>

Parameters

Parameter	Parameter description	Value	Value description
<tile>	Tile ID	1	The ID of Tile #1.
		2	The ID of Tile #2.
		3	The ID of Tile #3.
		4	The ID of Tile #4.

Example

- ▶ SET /MEDIA/VIDEO/O1.LayerOrder=2;1;3;4
- ◀ pw /MEDIA/VIDEO/O1.LayerOrder=2;1;3;4

7.8.6. Tile Opacity Setting

The setting adjusts the opacity of the selected tile. The opacity is in percent, 100% means the stream is not transparent, 0% means the stream is not visible. #tile



Command and Response

- ▶ SET•/MEDIA/VIDEO/<out>/<tile>.Opacity=<percent>
- ◀ pw•/MEDIA/VIDEO/<out>/<tile>.Opacity=<percent>

Example

- ▶ SET /MEDIA/VIDEO/O1/T1.Opacity=50
- ◀ pw /MEDIA/VIDEO/O1/T1.Opacity=50

7.8.7. Color Depth Setting

Command and Response #colordepth

- ▶ SET•/MEDIA/VIDEO/<out>.ColorDepthSetting=<color_depth>
- ◀ pw•/MEDIA/VIDEO/<out>.ColorDepthSetting=<color_depth>

Parameters

Parameter	Parameter description	Value	Value description
<color_depth>	Color depth setting	Pass	No color depth conversion
		8 bpc	Color depth is 8 bit/channel
		10 bpc	Color depth is 10 bit/channel
		12 bpc	Color depth is 12 bit/channel

Example

- ▶ SET /MEDIA/VIDEO/O1.ColorDepthSetting=8 bpc
- ◀ pw /MEDIA/VIDEO/O1.ColorDepthSetting=8 bpc

7.8.8. Querying the Status of the Tile

The query returns the actual status of the selected tile.

Command and Response

- ▶ GET•/MEDIA/VIDEO/<out>/<tile>.Status=<status>
- ◀ pr•/MEDIA/VIDEO/<out>/<tile>.Status=<status>

Parameters

Parameter	Parameter description	Value	Value description
<status>	Actual status of the tile	Disabled	The tile is muted. See the Enabling/Disabling the Tile section to unmute it.
		HdcpError	The HDCP authentication is failed.
		BandwidthError	The bandwidth of the tile stream exceeds the limit. See more details about the stream optimization in the Multiviewer Designer - Tutorial section and about the bandwidth limits in the Bandwidth Requirements of the Resolutions section.
		NoInput	There is no input stream for the tile.
		InvalidLayout	The tile is beyond the canvas. Check the position (Tile Position Setting) and the resolution (Tile Size Setting) of the tile to solve this issue.
		InvalidSize	The resolution of the input stream and the size of the tile is not equal.
		InvalidColorFormat	The color format of the input stream and the color format of the tile is not equal. UBEX multiviewer supports RGB color space only . Color space conversion on the TX side is available in the Color Space Converter Setting section (for TX) and the Color Space Converter Setting section (for TRX).
		Ok	The input stream is displayed in the tile correctly.

Example

- ▶ GET /MEDIA/VIDEO/01/T2.Status=Ok
- ◀ pr /MEDIA/VIDEO/01/T2.Status=Ok

7.8.9. No Sync Screen (Test Pattern) Mode

The No sync screen feature generates an image that can be displayed when there is no incoming signal on the port. The following method turns on or off the Test Pattern function.

■ INFO: When the no sync screen is enabled, the whole canvas area will display the test pattern.

Command and Response #testpattern #nosyncscreen

- ▶ SET•/MEDIA/VIDEO/<out>.NoSyncMode=<nosync_mode>
- ◀ pw•/MEDIA/VIDEO/<out>. NoSyncMode=<nosync_mode>

Parameters

Parameter	Parameter description	Value	Value description
<nosync_mode>	Test pattern mode setting	AlwaysOff	The test pattern is not displayed on the output.
		NoSignal	The test pattern is displayed if there is no video is received on the output port.
		AlwaysOn	The test pattern is displayed on the output even if there is an incoming signal.
		Freeze	The signal freezes at the last video frame on the sink device (the sink may show a broken frame too).

Example

- ▶ SET /MEDIA/VIDEO/01.NoSyncMode=NoSignal
- ◀ pw /MEDIA/VIDEO/01.NoSyncMode=NoSignal

7.8.10. No Sync Screen (Test Pattern) Color Setting

The No sync screen feature generates an image that can be displayed when there is no incoming signal on the port. The following method sets the displayed color defined in RGB code.

■ INFO: When the no sync screen is enabled, the whole canvas area will display the test pattern.

Command and Response

- ▶ SET•/MEDIA/VIDEO/<out>.NoSyncColor=<RGB_code>
- ◀ pw•/MEDIA/VIDEO/<out>. NoSyncColor=<RGB_code>

Example

- ▶ SET /MEDIA/VIDEO/01.NoSyncColor=128,128,128
- ◀ pw /MEDIA/VIDEO/01.NoSyncColor=128,128,128

7.8.11. HDCP Setting

HDCP capability can be set to Auto/Always on the output ports, thus non-encrypted content can be transmitted to a non-HDCP compliant display. See more information in the [HDCP Management](#) section.

INFO: In case of HDCP authentication problem of a tile, the whole canvas area will be filled with black pixels.

Command and Response *#hdc*

- ▶ SET•/MEDIA/VIDEO/<out>.HdcpMode=<HDCP_mode>
- ◀ pw•/MEDIA/VIDEO/<out>.HdcpMode=<HDCP_mode>

Parameters

Parameter	Parameter description	Value	Value description
<HDCP_mode>	HDCP mode	Auto	The level of the HDCP-encryption depends on the input.
		Always	The output ports set the maximum HDCP-encryption level that can be accepted by the connected sink device.
		AlwaysType1	The output ports always force HDCP 2.2 Type 1. If the sink device supports this HDCP-encryption level, the signal will be encrypted with HDCP 2.2 Type 0/1. The signal will be encrypted with HDCP 2.2 Type 1 when the source and the sink both support this HDCP-encryption level.

Example

- ▶ SET /MEDIA/VIDEO/01.HdcpMode=AlwaysType1
- ◀ pw /MEDIA/VIDEO/01.HdcpMode=AlwaysType1

7.8.12. Identify Stream / Identify Display

Calling the method generates 10 test colors on the display device for 10 seconds. The feature helps to identify the stream and the screen itself physically.

Command and Response *#identifystream #identifydisplay*

- ▶ CALL•/MEDIA/VIDEO/<out>.identify()
- ◀ mO•/MEDIA/VIDEO/<out>.identify

Example

- ▶ CALL /MEDIA/VIDEO/01:identify()
- ◀ mO /MEDIA/VIDEO/01:identify

Explanation



7.8.13. Querying the Source MUX Options

The source multiplexer (**Source MUX**) makes routing several different source signals to the HDMI output ports available. See more details about this function in the [Multiviewer Mode](#) section.

The query responds the available source signals for the selected output port.

Command and Response #mux #sourcemux

- ▶ GET•/MEDIA/VIDEO/<out>.SourceMuxOptions
- ◀ pr•/MEDIA/VIDEO/<out>.SourceMuxOptions=<mux_options>

Parameters

Parameter	Parameter description	Value	Value description
<mux_options>	The available sources for the output port	MV1	The MV1 (multiviewer) destination stream is selectable for the output port (only for O1).
		D5	The D5 destination stream is selectable for the output port (only for O2).
		I1	The stream of the I1 local input port is selectable for the output port (only for O1).
		I2	The stream of the I2 local input port is selectable for the output port (only for O2).
		O1	The copy of the stream of O1 output port is selectable for the output port (only for O2).

Example

- ▶ GET /MEDIA/VIDEO/O2.SourceMuxOptions
- ◀ pr /MEDIA/VIDEO/O2.SourceMuxOptions=I2;O1

7.8.14. Source MUX Setting

The source multiplexer (**Source MUX**) makes routing several different source signals to the HDMI output ports available. See more details about this function in the [Multiviewer Mode](#) section.

The command sets the source signal for the output port. Query the available options with the command described in the previous section.

Command and Response #mux #sourcemux

- ▶ SET•/MEDIA/VIDEO/<out>.SourceMux=<in|out>
- ◀ pw•/MEDIA/VIDEO/<out>.SourceMux=<in|out>

Example

- ▶ SET /MEDIA/VIDEO/O2.SourceMux=O1
- ◀ pw /MEDIA/VIDEO/O2.SourceMux=O1

7.9. Audio Port Settings

INFO: Audio port numbering can be found in the [Input/Output Port Numbering](#) section. #audio

7.9.1. Query the Status of Source Port

Command and Response #portstatus

- ▶ GET•/MEDIA/AUDIO/XP.SourcePortStatus
- ◀ pr•/MEDIA/AUDIO/XP.SourcePortStatus=<in_status>;...;<in_status>

The response contains 5 ASCII characters for each port. The first character indicates the mute/lock state, the next four characters represent a 2-byte HEX code shows the current state of the input ports.

Example

- ▶ GET /MEDIA/AUDIO/XP.SourcePortStatus
- ◀ pr /MEDIA/AUDIO/XP.SourcePortStatus=T000F;T000B;T000A;T000F

Legend

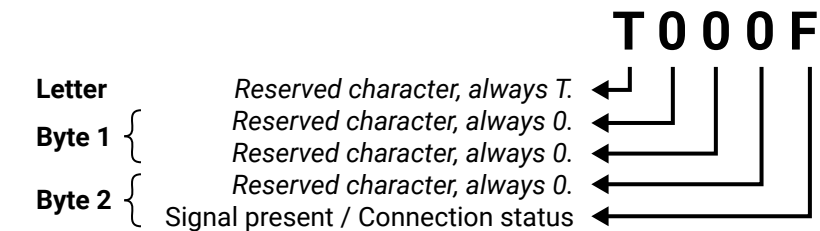

Example and Explanation (for input 1, T000F)

	Byte 1				Byte 2			
	Character 2		Character 3		Character 4		Character 5	
	BIT 7-6	BIT 5-4	BIT 3-2	BIT 1-0	BIT 7-6	BIT 5-4	BIT 3-2	BIT 1-0
	Reserved	Reserved	Reserved	Reserved	Reserved	Reserved	Signal present status	Connection status
00	Reserved	Reserved	Reserved	Reserved	Reserved	Reserved	Unknown	
01							Reserved	
10							No signal	Not connected
11							Signal presents	Connected

T	0		0		0		F	
Reserved	00	00	00	00	00	00	11	11
	Reserved	Reserved	Reserved	Reserved	Reserved	Reserved	Signal presents	Connected

The Most Common Received Port Status Responses

T0000	T	0		0		0		0	
	Reserved	00	00	00	00	00	00	00	00
	Reserved	Reserved	Reserved	Reserved	Reserved	Reserved	Reserved	Unknown	Unknown

T0008	T	0		0		0		8	
	Reserved	00	00	00	00	00	00	10	00
	Reserved	Reserved	Reserved	Reserved	Reserved	Reserved	Reserved	No signal	Unknown

T000A	T	0		0		0		A	
	Reserved	00	00	00	00	00	00	10	10
	Reserved	Reserved	Reserved	Reserved	Reserved	Reserved	Reserved	No signal	Not connected

T000B	T	0		0		0		B	
	Reserved	00	00	00	00	00	00	10	11
	Reserved	Reserved	Reserved	Reserved	Reserved	Reserved	Reserved	No signal	Connected

T000C	T	0		0		0		C	
	Reserved	00	00	00	00	00	00	11	00
	Reserved	Reserved	Reserved	Reserved	Reserved	Reserved	Reserved	Signal presents	Unknown

T000F	T	0		0		0		F	
	Reserved	00	00	00	00	00	00	11	11
	Reserved	Reserved	Reserved	Reserved	Reserved	Reserved	Reserved	Signal presents	Connected

7.9.2. Query the Status of Destination Port

Command and Response

- ▶ GET*/MEDIA/AUDIO/XP.DestinationPortStatus
- ◀ pr*/MEDIA/AUDIO/XP.DestinationPortStatus=<out_status>;...;<out_status>

The response contains 5 ASCII characters for each port. The first character indicates the mute/lock state, the next 2-byte-long HEX code shows the current state of the output ports.

Legend

See at the previous section.

Example

- ▶ GET /MEDIA/AUDIO/XP.DestinationPortStatus
- ◀ pr /MEDIA/AUDIO/XP.DestinationPortStatus=T000F;T000A;T000B;T000C

Example and Explanation (for output 1, T000F)

T	0		0		0		F	
Reserved	00	00	00	00	00	00	11	11
	Reserved	Reserved	Reserved	Reserved	Reserved	Reserved	Signal presents	Connected

7.9.3. Query the Audio Crosspoint Setting

Displays the current crosspoint setting about which audio stream is transmitted to the output ports of the device.

Command and Response

- ▶ GET*/MEDIA/AUDIO/XP.DestinationConnectionList
- ◀ pr*/MEDIA/AUDIO/XP.DestinationConnectionList=<source>;<source>

Example

- ▶ GET /MEDIA/AUDIO/XP.DestinationConnectionList
- ◀ pr /MEDIA/AUDIO/XP.DestinationConnectionList=S1;S2;S4;S4

S1 stream from input 1 is connected to the D1 sink, S2 stream from input 2 is connected to the D2 sink, S4 from the input 4 is connected to the D3 and D4 sinks.

7.9.4. Audio Stream Switching

Command and Response *#switch #crosspoint*

- ▶ CALL•/MEDIA/AUDIO/XP:switch(<source>:<destination>)
- ◀ mO•/MEDIA/AUDIO/XP:switch

Example

- ▶ CALL /MEDIA/AUDIO/XP:switch(S2:D1)
- ◀ mO /MEDIA/AUDIO/XP:switch

S2 stream audio is switched to D1 port.

7.9.5. Switching a Stream to All Destinations

Command and Response *#switch #crosspoint*

- ▶ CALL•/MEDIA/AUDIO/XP:switchAll(<source>)
- ◀ mO•/MEDIA/AUDIO/XP:switchAll

Example

- ▶ CALL /MEDIA/AUDIO/XP:switchAll(S2)
- ◀ mO /MEDIA/AUDIO/XP:switchAll

S2 stream is switched to the D1 and D2 sinks.

7.9.6. Enable/Disable the Audio Stream

Command and Response *#streamenable*

- ▶ SET•/MEDIA/AUDIO/<source|destination>.Enabled=true|false
- ◀ pw•/MEDIA/AUDIO/<source|destination>.Enabled=true|false

Example

- ▶ SET /MEDIA/AUDIO/S1.Enabled=true
- ◀ pw /MEDIA/AUDIO/S1.Enabled=true

7.10. Analog Audio Port Settings

DIFFERENCE: Only the UBEX-PRO20-HDMI-F110, -F111, -F120, -F121 and -F130 models are built with analog audio input and output ports.

INFO: Audio port numbering can be found in the [Input/Output Port Numbering](#) section.

7.10.1. Setting the Volume in dB

Command and Response *#analogaudio #volume*

- ▶ SET•/MEDIA/AUDIO/<in|out>.VolumedB=<volume>
- ◀ pw•/MEDIA/AUDIO/<in|out>.VolumedB=<volume>

Parameters

Parameter	Parameter description
<volume>	Sets the input volume (attenuation) between -95.62 dB and 0 dB.

Example

- ▶ SET /MEDIA/AUDIO/I3.VolumedB=-15
- ◀ pw /MEDIA/AUDIO/I3.VolumedB=-15.000

7.10.2. Setting the Volume in Percent

Command and Response

- ▶ SET•/MEDIA/AUDIO/<in|out>.VolumePercent=<percent>
- ◀ pw•/MEDIA/AUDIO/<in|out>.VolumePercent=<percent>

Example

- ▶ SET /MEDIA/AUDIO/O3.VolumePercent=50
- ◀ pw /MEDIA/AUDIO/O3.VolumePercent=50.00

7.10.3. Setting the Balance

Command and Response

- ▶ SET•/MEDIA/AUDIO/<in|out>.Balance=<balance>
- ◀ pw•/MEDIA/AUDIO/<in|out>.Balance=<balance>

Parameters

Parameter	Parameter description
<balance>	Sets the balance; -100 means left balance, +100 means right balance, step is 1. Center is 0 (default).

Example

- ▶ SET /MEDIA/AUDIO/I3.Balance=+25
- ◀ pw /MEDIA/AUDIO/I3.Balance=+25

7.10.4. Setting the Gain

INFO: The setting is available on the analog audio input port only.

Command and Response #balance #gain

- ▶ SET•/MEDIA/AUDIO/<in>.Gain=<gain>
- ◀ pw•/MEDIA/AUDIO/<in>.Gain=<gain>

Parameters

Parameter	Parameter description
<gain>	Sets the input gain between -12 dB and 35 dB.

Example

- ▶ SET /MEDIA/AUDIO/I3.Gain=4
- ◀ pw /MEDIA/AUDIO/I3.Gain=4

7.10.5. Mute/Unmute the Analog Audio Output Port

DIFFERENCE: The setting is available on the analog audio output port only.

Command and Response #mute #unmute

- ▶ SET•/MEDIA/AUDIO/<out>.Mute=<logical_value>
- ◀ pw•/MEDIA/AUDIO/<out>.Mute=<logical_value>

Parameters

Parameter	Parameter description	Value	Value description
<logical_value>	The port is muted or unmuted.	true	The port is muted.
		false	The port is unmuted.

Example

- ▶ SET /MEDIA/AUDIO/O3.Mute=false
- ◀ pw /MEDIA/AUDIO/O3.Mute=false

7.11. System Monitoring Commands

INFO: The following commands are independent of the current operation mode, they work in Transmitter, Receiver and Transceiver modes as well. #systemmonitor

7.11.1. Query Connected Device Presence

Connected property indicates that a cable or a device is connected to the port.

Command and Response

- ▶ GET•/MEDIA/VIDEO/<in|out>.Connected
- ◀ pr•/MEDIA/VIDEO/<in|out>.Connected=<parameter>

Parameters

Parameter	Parameter description	Value	Value description
<parameter>	Connected device or cable indicator	0	Connected
		1	Not connected
		F	Unknown

Example

- ▶ GET /MEDIA/VIDEO/I1.Connected
- ◀ pr /MEDIA/VIDEO/I1.Connected=1

7.11.2. Query Video Signal Presence

SignalPresent property indicates valid signal present on the port.

Command and Response

- ▶ GET•/MEDIA/VIDEO/<in|out|source|destination>.SignalPresent
- ◀ pr•/MEDIA/VIDEO/<in|out|source|destination>.SignalPresent=<parameter>

Parameters

Parameter	Parameter description	Value	Value description
<parameter>	Signal present indicator	0	Not present
		1	Present
		F	Unknown

Example

- ▶ GET /MEDIA/VIDEO/I1.SignalPresent
- ◀ pr /MEDIA/VIDEO/I1.SignalPresent=1

7.11.3. Query Embedded Audio Presence

EmbeddedAudioPresent property indicates that embedded audio is present in the video stream.

Command and Response

- ▶ GET•/MEDIA/VIDEO/<in|out|source|destination>.EmbeddedAudioPresent
- ◀ pr•/MEDIA/VIDEO/<in|out|source|destination>.EmbeddedAudioPresent=<parameter>

Parameters

Parameter	Parameter description	Value	Value description
<parameter>	Signal present indicator	0	Not present
		1	Present
		F	Unknown

Example

- ▶ GET /MEDIA/VIDEO/I1.EmbeddedAudioPresent
- ◀ pr /MEDIA/VIDEO/I1.EmbeddedAudioPresent=1

7.11.4. Query the Status of the Analog Audio Output

MuteStatus property indicates the current status of the analog audio output port.

DIFFERENCE: Only the UBEX-PRO20-HDMI-F110, -F111, -F120, -F121 and -F130 models are built with analog audio output port.

Command and Response

- ▶ GET•/MEDIA/AUDIO/<out>.MuteStatus
- ◀ pr•/MEDIA/VIDEO/<out>.MuteStatus=<status>

Parameters

Parameter	Parameter description	Value	Value description
<status>	Status of the analog audio output	nosignal	No signal is transmitted on the port.
		unmuted	The port is unmuted.
		muted	The port is muted.
		muted (unsupported)	The port is muted because the incoming signal is unsupported. Supported signal type: PCM, up to 48 kHz.
		disrupted	The audio signal is disrupted due to Ethernet packet loss.

Example

- ▶ GET /MEDIA/AUDIO/O3.MuteStatus
- ◀ pr /MEDIA/AUDIO/O3.MuteStatus=unmuted

7.11.5. Query the Signal Type

SignalType property provides the type of the video signal.

Command and Response

- ▶ GET•/MEDIA/VIDEO/<source|destination>.SignalType
- ◀ pr•/MEDIA/VIDEO/<source|destination>.SignalType=<signal_type>

Parameters

Parameter	Parameter description	Value	Value description
<signal_type>	Signal type	0	DVI
		1	HDMI
		F	Unknown

Example

- ▶ GET /MEDIA/VIDEO/S1.SignalType
- ◀ pr /MEDIA/VIDEO/S1.SignalType=1

7.11.6. Query the Resolution of the Stream

Command and Response

- ▶ GET•/MEDIA/VIDEO/<source|destination>.Resolution
- ◀ pr•/MEDIA/VIDEO/<source|destination>.Resolution=<resolution>

Example

- ▶ GET /MEDIA/VIDEO/S1.Resolution
- ◀ pr /MEDIA/VIDEO/S1.Resolution=3840x2160p60

7.11.7. Query the Bandwidth of the Stream

Bandwidth property provides the required Ethernet bandwidth of the stream.

Command and Response

- ▶ GET•/MEDIA/VIDEO/<source|destination>.Bandwidth
- ◀ pr•/MEDIA/VIDEO/<source|destination>.Bandwidth=<bandwidth>

Example

- ▶ GET /MEDIA/VIDEO/S1.Bandwidth
- ◀ pr /MEDIA/VIDEO/S1.Bandwidth=13.15

The bandwidth is in Gigabit/sec.

7.11.8. Query the Bandwidth Limitation Indicator

BandwidthLimitExceeded property indicates the signal bandwidth limit has been exceeded and the stream is disabled.

Command and Response

- ▶ GET•/MEDIA/VIDEO/<source|destination>.BandwidthLimitExceeded
- ◀ pr•/MEDIA/VIDEO/<source|destination>.BandwidthLimitExceeded=<logical_value>

Parameters

Parameter	Parameter description	Value	Value description
<logical_value>	Bandwidth limit has been exceeded or not.	true	The bandwidth of the Ethernet connection does NOT allow to send/receive the stream.
		false	The bandwidth of the Ethernet connection allows to send/receive the stream.

Example

- ▶ GET /MEDIA/VIDEO/S1.BandwidthLimitExceeded
- ◀ pr /MEDIA/VIDEO/S1.BandwidthLimitExceeded=false

7.11.9. Query the Link Aggregation Status

Querying of the recent status of the link aggregation between the SFP+ links.

Command and Response

- ▶ GET•/SYS/MB/UPLINK/<link>.LinkState
- ◀ pr•/SYS/MB/UPLINK/<link>.LinkState=<link_state>

Parameters

Parameter	Parameter description	Value	Value description
<link_state>	Status of the link aggregation between the SFP+ links	Down	The transmit and receive path of the 10 Gbps Ethernet link is not in operation.
		WaitingForAggregation	The SFP+ link is waiting for the aggregation.
		Up	The transmit and receive path of the 10 Gbps Ethernet link on both local and remote side is fully operational.

Example

- ▶ GET /SYS/MB/UPLINK/LINK1.LinkState
- ◀ pr /SYS/MB/UPLINK/LINK1.LinkState=Up

7.12. SFP+ Module Information

7.12.1. Query the Vendor

Querying of the vendor of the installed SFP+ module.

Command and Response #sfp

- ▶ GET•/SYS/MB/UPLINK/<link>/SFP.VendorName
- ◀ pr•/SYS/MB/UPLINK/<link>/SFP.VendorName=<vendor_name>

Example

- ▶ GET /SYS/MB/UPLINK/LINK1/SFP.VendorName
- ◀ pr /SYS/MB/UPLINK/LINK1/SFP.VendorName=FINISAR CORP.

7.12.2. Query the Part Number

Querying of the part number of the installed SFP+ module.

Command and Response

- ▶ GET•/SYS/MB/UPLINK/<link>/SFP.PartNumber
- ◀ pr•/SYS/MB/UPLINK/<link>/SFP.PartNumber=<partnumber>

Example

- ▶ GET /SYS/MB/UPLINK/LINK1/SFP.PartNumber
- ◀ pr /SYS/MB/UPLINK/LINK1/SFP.PartNumber=FTLX1471D3BCL

7.12.3. Query the Compliance

Querying of the standard compliance of the installed SFP+ module.

Command and Response

- ▶ GET•/SYS/MB/UPLINK/<link>/SFP.Compliance
- ◀ pr•/SYS/MB/UPLINK/<link>/SFP.Compliance=<compliance>

Example

- ▶ GET /SYS/MB/UPLINK/LINK1/SFP.Compliance
- ◀ pr /SYS/MB/UPLINK/LINK1/SFP.Compliance=10G BASE-LR

7.12.4. Query the Maximum Allowed Cable Length

Querying of the maximum allowed cable length of the installed SFP+ module. The parameter is in meters.

Command and Response

- ▶ GET•/SYS/MB/UPLINK/<link>/SFP.MaxLinkLength
- ◀ pr•/SYS/MB/UPLINK/<link>/SFP.MaxLinkLength=<length>

Example

- ▶ GET /SYS/MB/UPLINK/LINK1/SFP.MaxLinkLength
- ◀ pr /SYS/MB/UPLINK/LINK1/SFP.MaxLinkLength=10000

7.12.5. Query the Type of the Module

Querying of the type (singlemode, multimode, passive DAC, etc.) of the installed SFP+ module.

Command and Response

- ▶ GET•/SYS/MB/UPLINK/<link>/SFP.Type
- ◀ pr•/SYS/MB/UPLINK/<link>/SFP.Type=<type>

Example

- ▶ GET /SYS/MB/UPLINK/LINK1/SFP.Type
- ◀ pr /SYS/MB/UPLINK/LINK1/SFP.Type=Singlemode

7.12.6. Query the Compatibility of the Module

The query returns with the compatibility of the installed transceiver module. If it is false, the installed module may be SFP module (with 1 GbE signal transmission) instead of SFP+ module (with 10 GbE signal transmission).

Command and Response

- ▶ GET•/SYS/MB/UPLINK/<link>/SFP.Compatible
- ◀ pr•/SYS/MB/UPLINK/<link>/SFP.Compatible=<logical_value>

Parameters

Parameter	Parameter description	Value	Value description
<logical_value>	Compatibility of the module	true	The installed SFP+ module is compatible with the endpoint device.
		false	The installed module is not compatible. Possible root cause can be that the module is SFP instead of SFP+.

Example

- ▶ GET /SYS/MB/UPLINK/LINK1/SFP.Compatible
- ◀ pr /SYS/MB/UPLINK/LINK1/SFP.Compatible=true

7.13. EDID Management

INFO: The detailed description of the parameters in the EDID management section (E, D, U, F) can be found in the [Advanced EDID Management](#) section. #edid

Parameters

Parameter	Parameter description
<emulated>	The emulated EDID memory of the desired input port. Example: E1.
<dynamic>	Dynamic EDID memory index. Example: D1
<user>	User EDID memory index. Example: U1
<factory>	Factory EDID memory index. Example: F1

7.13.1. Query the Emulated EDIDs

Command and Response

- ▶ GET•/EDID.EdidStatus
- ◀ pr•/EDID.EdidStatus=<dynamic|user|factory>:<emulated>;<dynamic|user|factory>:<emulated>

Example

- ▶ GET /EDID.EdidStatus
- ◀ pr /EDID.EdidStatus=D3:E1;F48:E2

Emulated EDID slots are listed with the type and number of the EDID assigned to it. E.g. D3:E1 means that the 3rd dynamic EDID is emulated on port 1; F48:E2 means that the 48th FACTORY EDID is emulated on port 2 etc.

7.13.2. Query the Validity of a Dynamic EDID

Command and Response

- ▶ GET•/EDID/D/<dynamic>.Validity
- ◀ pr•/EDID/D/<dynamic>.Validity=<logical_value>

Parameters

The <logical_value> can be **true** or **false**.

Example

- ▶ GET /EDID/D/D1.Validity
- ◀ pr /EDID/D/D1.Validity=true

If the 'Validity' property is true then a valid EDID is stored in D1 memory place.

7.13.3. Query the Preferred Resolution of a User EDID

Command and Response

- ▶ GET•/EDID/U/<user>.PreferredResolution
- ◀ pr•/EDID/U/<user>.PreferredResolution=<resolution>

Example

- ▶ GET /EDID/U/U2.PreferredResolution
- ◀ pr /EDID/U/U2.PreferredResolution=1920x1080p60.00Hz

7.13.4. Emulating an EDID on an Input Port

Command and Response

- ▶ CALL•/EDID:switch(<dynamic|user|factory>:<emulated>)
- ◀ mO•/EDID:switch

Example

- ▶ CALL /EDID:switch(F49:E1;U3:E2)
- ◀ mO /EDID:switch

7.13.5. Copy an EDID to User Memory

Command and Response

- ▶ CALL•/EDID:copy(<dynamic|emulated|factory|user>:<user>)
- ◀ mO•/EDID:copy

Example

- ▶ CALL /EDID:copy(D1:U1;F148:U2)
- ◀ mO /EDID:copy

The EDID of the last connected sink of D1 (Output 1) is copied to U1, the F148 factory EDID is copied to U2.

7.13.6. Deleting an EDID from User Memory

Command and Response

- ▶ CALL•/EDID:delete(<user>)
- ◀ mO•/EDID:delete

Example

- ▶ CALL /EDID:delete(U1;U5)
- ◀ mO /EDID:delete

7.13.7. Resetting the Emulated EDIDs

Command and Response

- ▶ CALL•/EDID:reset()
- ◀ mO•/EDID:reset

Example

- ▶ CALL /EDID:reset()
- ◀ mO /EDID:reset

Calling this method switches all emulated EDIDs to factory default ones. See the table in the [Factory EDID List](#) section.

7.14. Network Configuration

ATTENTION: Calling the `ApplySettings()` method after the network setting is always required. See the details in the [Apply Network Settings](#) section. `#network #dhcp #ipaddress #mac`

7.14.1. Query the DHCP State

Command and Response

- ▶ GET•/MANAGEMENT/NETWORK.DhcpEnabled
- ◀ pw•/MANAGEMENT/NETWORK.DhcpEnabled=<logical_value>

Parameters

The <logical_value> can be **true** or **false**.

Example

- ▶ GET /MANAGEMENT/NETWORK.DhcpEnabled
- ◀ pw /MANAGEMENT/NETWORK.DhcpEnabled=true

7.14.2. Change the DHCP State

Command and Response

- ▶ SET•/MANAGEMENT/NETWORK.DhcpEnabled=<logical_value>
- ◀ pw•/MANAGEMENT/NETWORK.DhcpEnabled=<logical_value>

Parameters

The <logical_value> can be set to **true** or **false**.

Example

- ▶ SET /MANAGEMENT/NETWORK.DhcpEnabled=false
- ◀ pw /MANAGEMENT/NETWORK.DhcpEnabled=false

7.14.3. Query the MAC Address

Command and Response

- ▶ GET•/MANAGEMENT/NETWORK.MacAddress
- ◀ pr•/MANAGEMENT/NETWORK.MacAddress=<MAC_address>

Example

- ▶ GET /MANAGEMENT/NETWORK.MacAddress
- ◀ pr GET /MANAGEMENT/NETWORK.MacAddress=A8:D2:36:00:39:DA

7.14.4. Query the IP Address

Command and Response

- ▶ GET•/MANAGEMENT/NETWORK.IpAddress
- ◀ pr•/MANAGEMENT/NETWORK.IpAddress=<IP_address>

Example

- ▶ GET /MANAGEMENT/NETWORK.IpAddress
- ◀ pr /MANAGEMENT/NETWORK.IpAddress=192.168.0.100

7.14.5. Change the IP Address (Static)

Command and Response

- ▶ SET•/MANAGEMENT/NETWORK.StaticIpAddress=<IP_address>
- ◀ pw•/MANAGEMENT/NETWORK.StaticIpAddress=<IP_address>

Example

- ▶ SET /MANAGEMENT/NETWORK.StaticIpAddress=192.168.0.85
- ◀ pw /MANAGEMENT/NETWORK.StaticIpAddress=192.168.0.85

7.14.6. Query the Subnet Mask

Command and Response

- ▶ GET•/MANAGEMENT/NETWORK.NetworkMask
- ◀ pr•/MANAGEMENT/NETWORK.NetworkMask=<netmask>

Example

- ▶ GET /MANAGEMENT/NETWORK.NetworkMask
- ◀ pr /MANAGEMENT/NETWORK.NetworkMask=255.255.255.0

7.14.7. Change the Subnet Mask (Static)

Command and Response

- ▶ SET•/MANAGEMENT/NETWORK.StaticNetworkMask=<netmask>
- ◀ pw•/MANAGEMENT/NETWORK.StaticNetworkMask=<netmask>

Example

- ▶ SET /MANAGEMENT/NETWORK.StaticNetworkMask=255.255.255.0
- ◀ pw /MANAGEMENT/NETWORK.StaticNetworkMask=255.255.255.0

7.14.8. Query the Gateway Address

Command and Response

- ▶ GET•/MANAGEMENT/NETWORK.GatewayAddress
- ◀ pr•/MANAGEMENT/NETWORK.GatewayAddress=<gw_address>

Example

- ▶ GET /MANAGEMENT/NETWORK.GatewayAddress
- ◀ pr /MANAGEMENT/NETWORK.GatewayAddress=192.168.0.1

7.14.9. Change the Gateway Address (Static)

Command and Response

- ▶ SET•/MANAGEMENT/NETWORK.StaticGatewayAddress=<gw_address>
- ◀ pw•/MANAGEMENT/NETWORK.StaticGatewayAddress=<gw_address>

Example

- ▶ SET /MANAGEMENT/NETWORK.StaticGatewayAddress=192.168.0.1
- ◀ pw /MANAGEMENT/NETWORK.StaticGatewayAddress=192.168.0.1

7.14.10. Apply Network Settings

Command and Response

- ▶ CALL•/MANAGEMENT/NETWORK:ApplySettings()
- ◀ mO•/MANAGEMENT/NETWORK:ApplySettings

Example

- ▶ CALL /MANAGEMENT/NETWORK:ApplySettings()
- ◀ mO /MANAGEMENT/NETWORK:ApplySettings

7.14.11. Query the IP Address of the Remote Endpoint

Querying of the IP address of the connected transmitter or receiver.

Command and Response

- ▶ GET•/REMOTE.RemotelpAddress
- ◀ pr•/REMOTE.RemotelpAddress=<IP_Address>

Example

- ▶ GET /REMOTE.RemotelpAddress
- ◀ pr /REMOTE.RemotelpAddress=192.168.0.111

7.15. RS-232 Port Configuration

DIFFERENCE: Only the UBEX-PRO20-HDMI-F110, -F111, -F120, -F121 and -F130 models are built with serial interface port. *#rs232 #rs-232 #serial*

7.15.1. Query the Current Configuration

Command and Response

- ▶ GET•/MEDIA/UART/<port>.Rs232Configuration
- ◀ pr•/MEDIA/UART/<port>.Rs232Configuration=<configuration>

Example

- ▶ GET /MEDIA/UART/P1.Rs232Configuration
- ◀ pr /MEDIA/UART/P1.Rs232Configuration=57600, 8N1

Explanation

BAUD rate is 57600, databits are 8, the parity is N as none, the stopbits are 1.

7.15.2. BAUD Rate Setting

Command and Response

- ▶ SET•/MEDIA/UART/<port>.Baudrate=<number>
- ◀ pw•/MEDIA/UART/<port>.Baudrate=<number>

Parameters

Parameter	Parameter description	Value	Value description
<number>	Baud rate value	0	4800
		1	7200
		2	9600
		3	14400
		4	19200
		5	38400
		6	57600
		7	115200

Example

- ▶ SET /MEDIA/UART/P1.Baudrate=7
- ◀ pw /MEDIA/UART/P1.Baudrate=7

7.15.3. Parity Setting

Command and Response

- ▶ SET•/MEDIA/UART/<port>.Parity=<number>
- ◀ pw•/MEDIA/UART/<port>.Parity=<number>

Parameters

Parameter	Parameter description	Value	Value description
<number>	Parity value	0	None
		1	Odd
		2	Even

Example

- ▶ SET /MEDIA/UART/P1.Parity=0
- ◀ pw /MEDIA/UART/P1.Parity=0

7.15.4. Stopbits Setting

Command and Response

- ▶ SET•/MEDIA/UART/<port>.StopBits=<number>
- ◀ pw•/MEDIA/UART/<port>.StopBits=<number>

Parameters

Parameter	Parameter description	Value	Value description
<number>	Stop bits value	0	1
		1	1,5
		2	2

Example

- ▶ SET /MEDIA/UART/P1.StopBits=0
- ◀ pw /MEDIA/UART/P1.StopBits=0

7.15.5. Databits Setting

Command and Response

- ▶ SET•/MEDIA/UART/<port>.DataBits=<number>
- ◀ pw•/MEDIA/UART/<port>.DataBits=<number>

Parameters

Parameter	Parameter description	Value	Value description
<number>	Databits value	8	8 databits
		9	9 databits

Example

- ▶ SET /MEDIA/UART/P1.DataBits=8
- ◀ pw /MEDIA/UART/P1.DataBits=8

7.15.6. Command Injection TCP Port Setting

Command and Response

- ▶ SET•/MEDIA/UART/<port>.CommandInjectionPort=<port>
- ◀ pw•/MEDIA/UART/<port>.CommandInjectionPort=<port>

Example

- ▶ SET /MEDIA/UART/P1.CommandInjectionPort=8001
- ◀ pw /MEDIA/UART/P1.CommandInjectionPort=8001

7.16. Infrared Port Configuration

DIFFERENCE: Only the UBEX-PRO20-HDMI-F110 and F120 models are built with Infrared interface port.

#infra #ir

Parameters

Parameter	Parameter description
<in>	IR input port, example: S1
<out>	IR output port, example: D1

7.16.1. Enable/Disable the Port

Command and Response

- ▶ SET·/MEDIA/IR/<in|out>.Enable=<logical_value>
- ◀ pw·/MEDIA/IR/<in|out>.Enable=<logical_value>

Parameters

Parameter	Parameter description	Value	Value description
<logical_value>	Port enable/disable setting	true	The port is enabled.
		false	The port is disabled.

Example

- ▶ SET /MEDIA/IR/S1.Enable=true
- ◀ pw /MEDIA/IR/S1.Enable=true

7.16.2. Enable Command Injection

Command and Response

- ▶ SET·/MEDIA/IR/<in|out>.CommandInjectionEnable=<logical_value>
- ◀ pw·/MEDIA/IR/<in|out>.CommandInjectionEnable=<logical_value>

Parameters

Parameter	Parameter description	Value	Value description
<logical_value>	Command injection enable/disable setting	true	Command injection is enabled.
		false	Command injection is disabled.

Example

- ▶ SET /MEDIA/IR/D1.CommandInjectionEnable=true
- ◀ pw /MEDIA/IR/D1.CommandInjectionEnable=true

7.16.3. Change Command Injection Port Number

Command and Response

- ▶ SET·/MEDIA/IR/<in|out>.CommandInjectionPort=<port_no>
- ◀ pw·/MEDIA/IR/<in|out>.CommandInjectionPort=<port_no>

Example

- ▶ SET /MEDIA/IR/S1.CommandInjectionPort=9001
- ◀ pw /MEDIA/IR/S1.CommandInjectionPort=9001

7.16.4. Enable/Disable Output Signal Modulation

Command and Response

- ▶ SET·/MEDIA/IR/<out>.EnableModulation=<logical_value>
- ◀ pw·/MEDIA/IR/<out>.EnableModulation=<logical_value>

Parameters

Parameter	Parameter description	Value	Value description
<logical_value>	Signal modulation enable/disable setting	true	The signal modulation is enabled.
		false	The signal modulation is disabled.

Example

- ▶ SET /MEDIA/IR/D1.EnableModulation=false
- ◀ pw /MEDIA/IR/D1.EnableModulation=false

INFO: The default setting value is **true** (enabled).

7.17. Message Sending via Communication Ports

7.17.1. Sending a Text (ASCII-format) via Serial Port

DIFFERENCE: Only UBEX-PRO20-HDMI-F110, -F111, -F120, -F121 and -F130 models are built with serial interface ports.

The command is for sending a command message in ASCII-format. This method **does not allow** sending message with control and non-printable characters.

Command and Response

- ▶ CALL·/MEDIA/UART/<port>:sendText(<message>)
- ◀ mO·/MEDIA/UART/<port>:sendText

Example

- ▶ CALL /MEDIA/UART/P1:sendText(open)
- ◀ mO /MEDIA/UART/P1:sendText

The 'open' text is sent out via the P1 serial port. #message

7.18.3. Disconnecting the Receiver Port

Command and Response

- ▶ CALL /MEDIA/KM/XP:switch(0:<r>)
- ◀ mO /MEDIA/KM/XP:switch

Example

- ▶ CALL /MEDIA/KM/XP:switch(0:R1)
- ◀ mO /MEDIA/KM/XP:switch

7.18.4. Enable/Disable the Receiver Port

Command and Response

- ▶ SET /MEDIA/KM/<u>.Enabled
- ◀ pw /MEDIA/KM/<u>.Enabled=<logical_value>

Parameters

Parameter	Parameter description	Value	Value description
<logical_value>	Enable/disable the receiver port.	true	Receiver port is enabled.
		false	Receiver port is disabled.

Example

- ▶ GET /MEDIA/KM/D1.Enabled
- ◀ pr /MEDIA/KM/D1.Enabled=true

7.18.5. Querying the Presence of the USB-A Device

Command and Response

- ▶ GET /MEDIA/KM/<d>.DevicePresent
- ◀ pr /MEDIA/KM/<d>.DevicePresent=<logical_value>

Parameters

Parameter	Parameter description	Value	Value description
<logical_value>	Device presence indicator	true	USB-A device is present.
		false	USB-A device is not present.

Example

- ▶ GET /MEDIA/KM/D1.DevicePresent
- ◀ pr /MEDIA/KM/D1.DevicePresent=true

7.18.6. Querying the Product Name of the USB-A Device

Command and Response

- ▶ GET /MEDIA/KM/<d>.Product
- ◀ pr /MEDIA/KM/<d>.Product=<product_name>

Example

- ▶ GET /MEDIA/KM/D1.Product
- ◀ pr /MEDIA/KM/D1.Product=USB Optical Mouse

7.18.7. Querying the Manufacturer of the USB-A Device

Command and Response

- ▶ GET /MEDIA/KM/<d>.Manufacturer
- ◀ pr /MEDIA/KM/<d>.Manufacturer=<manufacturer>

Example

- ▶ GET /MEDIA/KM/D2.Manufacturer
- ◀ pr /MEDIA/KM/D2.Manufacturer=Logitech

7.18.8. Querying the Serial Number of the USB-A Device

Command and Response

- ▶ GET /MEDIA/KM/<d>.Serial
- ◀ pr /MEDIA/KM/<d>.Serial=<serial_number>

Example

- ▶ GET /MEDIA/KM/D1.Serial
- ◀ pr /MEDIA/KM/D1.Serial=0123456789

7.18.9. Querying the Device Class of the USB-A Device

Command and Response

- ▶ GET /MEDIA/KM/<d>.DeviceClass
- ◀ pr /MEDIA/KM/<d>.DeviceClass=<deviceclass>

Example

- ▶ GET /MEDIA/KM/D2.DeviceClass
- ◀ pr /MEDIA/KM/D2.DeviceClass=InterfaceClass

7.18.10. Querying the Interface Classes of the USB-A Device

Command and Response

- ▶ GET·/MEDIA/KM/<d>.InterfaceClasses
- ◀ pr·/MEDIA/KM/<d>.InterfaceClasses=<interface_classes>

Example

- ▶ GET /MEDIA/KM/D2.InterfaceClasses
- ◀ pr /MEDIA/KM/D2.InterfaceClasses=HID + HID

7.18.11. Enable/Disable Power Sending of the USB-A Port

Command and Response

- ▶ SET·/MEDIA/KM/<d>.Power
- ◀ pw·/MEDIA/KM/<d>.Power=<logical_value>

Parameters

Parameter	Parameter description	Value	Value description
<logical_value>	Enable/disable power sending of the USB-A port.	true	Feature is enabled.
		false	Feature is disabled.

Example

- ▶ SET /MEDIA/KM/D1.Power
- ◀ pw /MEDIA/KM/D1.Power=true

7.18.12. Enable/Disable Suspending of the USB-A Port

Command and Response

- ▶ SET·/MEDIA/KM/<d>.Suspend
- ◀ pw·/MEDIA/KM/<d>.Suspend=<logical_value>

Parameters

Parameter	Parameter description	Value	Value description
<logical_value>	Enable/disable suspending of the USB-A port.	true	Suspend is enabled.
		false	Suspend is disabled.

Example

- ▶ SET /MEDIA/KM/D1.Suspend
- ◀ pw /MEDIA/KM/D1.Suspend=false

7.19. USB KVM Settings (F130 Model)

DIFFERENCE: Only UBEX-PRO20-HDMI-F130 model is built with USB KVM and USB 2.0 ports. #kvm #usbkvm #icron

Parameters

Parameter	Parameter description	Value	Value description
<e>	Emulated USB HID (source; USB-A) port of the endpoint	E1	Local emulated port
		E2	Remote emulated port
<d>	Downstream - signal of the USB HID ports (USB-A)	D1	Right local USB-A port
		D2	Left local USB-A port
<r>	Receiver (destination; USB-C) port of the endpoint	R1	Local receiver port
		R2	Remote receiver port
<u>	Upstream - signal of the USB-C device	U1	Local USB-C port

7.19.1. Setting the Operation Mode of the Icron USB 2.0 Module

Three operation modes can be set to the Icron USB 2.0 module: **Local** (LEX), **Remote** (REX), or **Disabled**. See more details about it in the [USB KVM / USB 2.0 Interface \(F130 Model\)](#) section.

Command and Response

- ▶ SET·/MANAGEMENT/ICRON.OperationMode=<operation_mode>
- ◀ pw·/MANAGEMENT/ICRON.OperationMode=<operation_mode>

Parameters

Parameter	Parameter description	Value	Value description
<operation_mode>	Operation mode setting of the Icron USB 2.0 module	Local	Local (LEX) mode is active, see more details in the section.
		Remote	Remote (REX) mode is active, see more details in the section.
		Disabled	Icron module is disabled.

Example

- ▶ SET /MANAGEMENT/ICRON.OperationMode=Remote
- ◀ pw /MANAGEMENT/ICRON.OperationMode=Remote

7.19.2. Querying the MAC Address of the Icron Module

The MAC address of the Icron module is important to pair the device to another Icron module. See more details about the device pairing methods in the [Pairing the Icron Devices](#) section. *#mac*

Command and Response

- ▶ GET·/MANAGEMENT/ICRON.MacAddress
- ◀ pr·/MANAGEMENT/ICRON.MacAddress=<mac_address>

Example

- ▶ GET /MANAGEMENT/ICRON.MacAddress
- ◀ pr /MANAGEMENT/ICRON.MacAddress=A8:D2:36:F3:73:76

7.19.3. Querying the IP Address of the Icron Module

Command and Response *#ipaddress*

- ▶ GET·/MANAGEMENT/ICRON.IpAddress
- ◀ pr·/MANAGEMENT/ICRON.IpAddress=<mac_address>

Example

- ▶ GET /MANAGEMENT/ICRON.IpAddress
- ◀ pr /MANAGEMENT/ICRON.IpAddress=192.168.0.111

7.19.4. Switching the Emulated Port to the Remote Receiver

The command sets the USB HID ports to **Remote** control mode.

Command and Response

- ▶ CALL·/MEDIA/KM/XP:switch(<e>;<r>)
- ◀ mO·/MEDIA/KM/XP:switch

Example

- ▶ CALL /MEDIA/KM/XP:switch(E1:R2)
- ◀ mO /MEDIA/KM/XP:switch

7.19.5. Switching the Local Emulated Port to the Local Receiver

The command sets the USB HID ports to **Local** control mode.

It is possible to connect the local controlled device with the local keyboard & mouse plugged in the same endpoint. For this purpose you can use the same *switch()* command filling it with the same source and destination port number.

Command and Response

- ▶ CALL·/MEDIA/KM/XP:switch(<eN>;<rN>)
- ◀ mO·/MEDIA/KM/XP:switch

Example

- ▶ CALL /MEDIA/KM/XP:switch(E1:R1)
- ◀ mO /MEDIA/KM/XP:switch

7.19.6. Disconnecting the Receiver Port

Command and Response

- ▶ CALL·/MEDIA/KM/XP:switch(0;<r>)
- ◀ mO·/MEDIA/KM/XP:switch

Example

- ▶ CALL /MEDIA/KM/XP:switch(0:R1)
- ◀ mO /MEDIA/KM/XP:switch

7.19.7. Enable/Disable the Receiver Port

Command and Response

- ▶ SET·/MEDIA/KM/<u>.Enabled
- ◀ pw·/MEDIA/KM/<u>.Enabled=<logical_value>

Parameters

Parameter	Parameter description	Value	Value description
<logical_value>	Enable/disable the receiver port.	true	Receiver port is enabled.
		false	Receiver port is disabled.

Example

- ▶ SET /MEDIA/KM/D1.Enabled
- ◀ pw /MEDIA/KM/D1.Enabled=true

7.19.8. Querying the Presence of the USB HID Device

Command and Response

- ▶ GET·/MEDIA/KM/<d>.DevicePresent
- ◀ pr·/MEDIA/KM/<d>.DevicePresent=<logical_value>

Parameters

Parameter	Parameter description	Value	Value description
<logical_value>	Device presence indicator	true	USB-A device is present.
		false	USB-A device is not present.

Example

- ▶ GET /MEDIA/KM/D1.DevicePresent
- ◀ pr /MEDIA/KM/D1.DevicePresent=true

7.19.9. Querying the Product Name of the USB HID Device

Command and Response

- ▶ GET·/MEDIA/KM/<d>.Product
- ◀ pr·/MEDIA/KM/<d>.Product=<product_name>

Example

- ▶ GET /MEDIA/KM/D1.Product
- ◀ pr /MEDIA/KM/D1.Product=USB Optical Mouse

7.19.10. Querying the Manufacturer of the USB HID Device

Command and Response

- ▶ GET·/MEDIA/KM/<d>.Manufacturer
- ◀ pr·/MEDIA/KM/<d>.Manufacturer=<manufacturer>

Example

- ▶ GET /MEDIA/KM/D2.Manufacturer
- ◀ pr /MEDIA/KM/D2.Manufacturer=Logitech

7.19.11. Querying the Serial Number of the USB HID Device

Command and Response

- ▶ GET·/MEDIA/KM/<d>.Serial
- ◀ pr·/MEDIA/KM/<d>.Serial=<serial_number>

Example

- ▶ GET /MEDIA/KM/D1.Serial
- ◀ pr /MEDIA/KM/D1.Serial=0123456789

7.19.12. Querying the Device Class of the USB HID Device

Command and Response

- ▶ GET·/MEDIA/KM/<d>.DeviceClass
- ◀ pr·/MEDIA/KM/<d>.DeviceClass=<deviceclass>

Example

- ▶ GET /MEDIA/KM/D2.DeviceClass
- ◀ pr /MEDIA/KM/D2.DeviceClass=InterfaceClass

7.19.13. Querying the Interface Classes of the USB HID Device

Command and Response

- ▶ GET·/MEDIA/KM/<d>.InterfaceClasses
- ◀ pr·/MEDIA/KM/<d>.InterfaceClasses=<interface_classes>

Example

- ▶ GET /MEDIA/KM/D2.InterfaceClasses
- ◀ pr /MEDIA/KM/D2.InterfaceClasses=HID + HID

7.19.14. Enable/Disable Power Sending of the USB HID Port

Command and Response

- ▶ SET·/MEDIA/KM/<d>.Power=<logical_value>
- ◀ pw·/MEDIA/KM/<d>.Power=<logical_value>

Parameters

Parameter	Parameter description	Value	Value description
<logical_value>	Enable/disable power sending of the USB-A port.	true	Feature is enabled.
		false	Feature is disabled.

Example

- ▶ SET /MEDIA/KM/D1.Power=true
- ◀ pw /MEDIA/KM/D1.Power=true

7.19.15. Enable/Disable Suspending of the USB HID Port

Command and Response

- ▶ SET·/MEDIA/KM/<d>.Suspend=<logical_value>
- ◀ pw·/MEDIA/KM/<d>.Suspend=<logical_value>

Parameters

Parameter	Parameter description	Value	Value description
<logical_value>	Enable/disable suspending of the USB-A port.	true	Suspend is enabled.
		false	Suspend is disabled.

Example

- ▶ SET /MEDIA/KM/D1.Suspend=false
- ◀ pw /MEDIA/KM/D1.Suspend=false

7.20. LW3 Protocol Commands - Quick Summary

System Commands

Set the Device Label

- ▶ SET•/MANAGEMENT/LABEL.DeviceLabel=<Custom_name>

Querying the Product Name

- ▶ GET•/.ProductName

Query the Firmware Package Version

- ▶ GET•/MANAGEMENT/UID/PACKAGE.Version

Display Custom Text on the LCD

- ▶ CALL•/MANAGEMENT/UI:displayMessage(<text>)

Display Custom Color on the LCD

- ▶ CALL•/MANAGEMENT/UI:testDisplay(<mode>,<hex_code>)

Identify the Device

- ▶ CALL•/MANAGEMENT/UI:identifyMe()

Dark Mode Setting

- ▶ SET•/MANAGEMENT/UI/DARKMODE.DarkModeEnable=<logical_value>

Dark Mode Delay Setting

- ▶ SET•/MANAGEMENT/UI/DARKMODE.DarkModeDelay=<second>

Query the Operation Mode

- ▶ GET•/SYS/MB.OperationMode

Set the Operation Mode

- ▶ CALL•/SYS/MB.setOperationModeAndReset=<operation_mode>

Query the Application Mode

- ▶ GET•/SYS/MB.ApplicationMode

Application Mode Selection

- ▶ SET•/SYS/MB.ApplicationModeSelection=<application_mode>

Setting the Rotary Direction of the Jog Dial Knob

- ▶ SET•/MANAGEMENT/UI.RotaryDirection=<parameter>

Setting the Brightness of the LCD Screen

- ▶ SET•/MANAGEMENT/UI.DisplayBrightness=<parameter>

Control Lock

- ▶ SET•/MANAGEMENT/UI.ControlLock=<parameter>

Bootload Mode Setting

- ▶ CALL•/SYS:bootload()

Restarting the Device

- ▶ CALL•/SYS:reset()

Restore the Factory Default Settings

- ▶ CALL•/SYS:factoryDefaults()

Video Port Settings - Transmitter Mode

Query the Status of Source Port

- ▶ GET•/MEDIA/VIDEO/XP.SourcePortStatus

Query the Status of Destination Port

- ▶ GET•/MEDIA/VIDEO/XP.DestinationPortStatus

Query the Video Crosspoint Setting

- ▶ GET•/MEDIA/VIDEO/XP.DestinationConnectionList

Switching the Stream

- ▶ CALL•/MEDIA/VIDEO/XP:switch(<source>:<destination>)

Switching a Stream to All Destinations

- ▶ CALL•/MEDIA/VIDEO/XP:switchAll(<source>)

Enable/Disable the Stream

- ▶ SET•/MEDIA/VIDEO/<source>.Enabled=<logical_value>

Identify Stream

- ▶ CALL•/MEDIA/VIDEO/<source>:identify()

Resolution Setting

- ▶ SET•/MEDIA/VIDEO/<source>.ResolutionSetting=<resolution>

Resolution Mode Setting

- ▶ SET•/MEDIA/VIDEO/<source>.ResolutionMode=<resolution_mode>

Scaler - Image Position Setting

- ▶ SET•/MEDIA/VIDEO/<source>.ImagePosition=<image_position>

Tile Resolution Setting

- ▶ SET•/MEDIA/VIDEO/<source>.TileResolutionSetting=<resolution>

Color Space Converter Setting

- ▶ SET•/MEDIA/VIDEO/<source>.ColorSpaceSetting=<color_space>

Color Range Setting

- ▶ SET•/MEDIA/VIDEO/<source>.ColorRangeSetting=<color_range>

Color Depth Setting

- ▶ SET•/MEDIA/VIDEO/<source>.ColorDepthSetting=<color_depth>

Query the Timing Mode

- ▶ GET•/MEDIA/VIDEO/<source>.TimingMode

HDCP Setting (Input Port)

- ▶ SET•/MEDIA/VIDEO/<in>.HdcpEnable=<logical_value>

HDCP Setting (Output Port)

- ▶ SET•/MEDIA/VIDEO/<out>.HdcpMode=<HDCP_mode>

Video Port Settings - Receiver Mode**Query the Status of Source Port**

- ▶ GET•/MEDIA/VIDEO/XP.SourcePortStatus

Query the Status of Destination Port

- ▶ GET•/MEDIA/VIDEO/XP.DestinationPortStatus

Query the Video Crosspoint Setting

- ▶ GET•/MEDIA/VIDEO/XP.DestinationConnectionList

Switching the Stream

- ▶ CALL•/MEDIA/VIDEO/XP:switch(<source>:<destination>)

Switching a Stream to All Destinations

- ▶ CALL•/MEDIA/VIDEO/XP:switchAll(<source>)

Disconnecting the Stream

- ▶ CALL•/MEDIA/VIDEO/XP:switch(0:<destination>)

Enable/Disable the Stream

- ▶ SET•/MEDIA/VIDEO/<destination>.Enabled=<logical_value>

Resolution Mode Setting

- ▶ SET•/MEDIA/VIDEO/<out>.ResolutionMode=<resolution_mode>

Query the EDID Based Resolution

- ▶ GET•/MEDIA/VIDEO/<out>.EdidBasedResolution

Resolution Setting

- ▶ SET•/MEDIA/VIDEO/<out>.ResolutionSetting=<resolution>

Scaler - Image Position Setting

- ▶ SET•/MEDIA/VIDEO/<out>.ImagePosition=<image_position>

Color Space Converter Setting

- ▶ SET•/MEDIA/VIDEO/<out>.ColorSpaceSetting=<color_space>

Color Range Setting

- ▶ SET•/MEDIA/VIDEO/<source>.ColorRangeSetting=<color_range>

Color Depth Setting

- ▶ SET•/MEDIA/VIDEO/<out>.ColorDepthSetting=<color_depth>

Query the Timing Mode

- ▶ GET•/MEDIA/VIDEO/<out>.TimingMode

Timing Mode Setting

- ▶ SET•/MEDIA/VIDEO/<out>.TimingModeSetting=<timing_mode>

Enable Signal Freeze

- ▶ CALL•/MEDIA/VIDEO/<out>:freezeSignal()

Disable Signal Freeze

- ▶ CALL•/MEDIA/VIDEO/<out>:unfreezeSignal()

No Sync Screen (Test Pattern) Mode

- ▶ SET•/MEDIA/VIDEO/<out>.NoSyncMode=<nosync_mode>

No Sync Screen (Test Pattern) Color Setting

- ▶ SET•/MEDIA/VIDEO/<out>.NoSyncColor=<RGB_code>

HDCP Setting (Input Port)

- ▶ SET•/MEDIA/VIDEO/<in>.HdcpEnable=<logical_value>

HDCP Setting (Output Port)

- ▶ SET•/MEDIA/VIDEO/<out>.HdcpMode=<HDCP_mode>

Identify Display

- ▶ CALL•/MEDIA/VIDEO/<out>:identify()

Query the Source MUX Options

- ▶ GET•/MEDIA/VIDEO/<out>.SourceMuxOptions

Source MUX Setting

- ▶ SET•/MEDIA/VIDEO/<out>.SourceMux=<destination|in|out>

Video Port Settings - Transceiver Mode**Query the Status of Source Port**

- ▶ GET•/MEDIA/VIDEO/XP.SourcePortStatus

Query the Status of Destination Port

- ▶ GET•/MEDIA/VIDEO/XP.DestinationPortStatus

Switching the Stream

- ▶ CALL•/MEDIA/VIDEO/XP:switch(<source>:<destination>)

Disconnecting the Stream

- ▶ CALL•/MEDIA/VIDEO/XP:switch(0:<destination>)

Enable/Disable the Stream

- ▶ SET•/MEDIA/VIDEO/<source>.Enabled=<logical_value>

Identify Stream / Identify Display

- ▶ CALL•/MEDIA/VIDEO/<source|out>.identify()

Resolution Mode Setting - Input Side

- ▶ SET•/MEDIA/VIDEO/<source>.ResolutionMode=<resolution_mode>

Resolution Mode Setting - Output Side

- ▶ SET•/MEDIA/VIDEO/<out>.ResolutionMode=<resolution_mode>

Query the EDID Based Resolution

- ▶ GET•/MEDIA/VIDEO/<out>.EdidBasedResolution

Resolution Setting

- ▶ SET•/MEDIA/VIDEO/<source|out>.ResolutionSetting=<resolution>

Scaler - Image Position Setting

- ▶ SET•/MEDIA/VIDEO/<source|out>.ImagePosition=<image_position>

Tile Resolution Setting

- ▶ SET•/MEDIA/VIDEO/<source>.TileResolutionSetting=<resolution>

Color Space Converter Setting

- ▶ SET•/MEDIA/VIDEO/<source|out>.ColorSpaceSetting=<color_space>

Color Range Setting

- ▶ SET•/MEDIA/VIDEO/<source|out>.ColorRangeSetting=<color_range>

Color Depth Setting

- ▶ SET•/MEDIA/VIDEO/<source|out>.ColorDepthSetting=<color_depth>

Query the Timing Mode

- ▶ GET•/MEDIA/VIDEO/<source|out>.TimingMode

Timing Mode Setting

- ▶ SET•/MEDIA/VIDEO/<out>.TimingModeSetting=<timing_mode>

Enable Signal Freeze

- ▶ CALL•/MEDIA/VIDEO/<out>:freezeSignal()

Disable Signal Freeze

- ▶ CALL•/MEDIA/VIDEO/<out>:unfreezeSignal()

No Sync Screen (Test Pattern) Mode

- ▶ SET•/MEDIA/VIDEO/<out>.NoSyncMode=<nosync_mode>

No Sync Screen (Test Pattern) Color Setting

- ▶ SET•/MEDIA/VIDEO/<out>.NoSyncColor=<RGB_code>

HDCP Setting (Input Port)

- ▶ SET•/MEDIA/VIDEO/<in>.HdcpEnable=<logical_value>

HDCP Setting (Output Port)

- ▶ SET•/MEDIA/VIDEO/<out>.HdcpMode=<HDCP_mode>

Querying the Source MUX Options

- ▶ GET•/MEDIA/VIDEO/<out>.SourceMuxOptions

Source MUX Setting

- ▶ SET•/MEDIA/VIDEO/<out>.SourceMux=<in|out>

Multiviewer Configuration**Setting the Resolution of the Canvas**

- ▶ SET•/MEDIA/VIDEO/<out>.ResolutionSetting=<resolution>

Enabling/Disabling the Tile

- ▶ SET•/MEDIA/VIDEO/<out>/<tile>.Enabled=<logical_value>

Tile Position Setting

- ▶ SET•/MEDIA/VIDEO/<out>/<tile>.Position=<horizontal_pixels>, <vertical_pixels>

Tile Size Setting

- ▶ SET•/MEDIA/VIDEO/<out>/<tile>.Size=<horizontal_pixels>x<vertical_pixels>

Layer Order Setting

- ▶ SET•/MEDIA/VIDEO/<out>.LayerOrder=<tile_ID>;<tile_ID>;<tile_ID>;<tile_ID>

Tile Opacity Setting

- ▶ SET•/MEDIA/VIDEO/<out>/<tile>.Opacity=<percent>

Color Depth Setting

- ▶ SET•/MEDIA/VIDEO/<out>.ColorDepthSetting=<color_depth>

Querying the Status of the Tile

- ▶ GET•/MEDIA/VIDEO/<out>/<tile>.Status=<status>

No Sync Screen (Test Pattern) Mode

- ▶ SET•/MEDIA/VIDEO/<out>.NoSyncMode=<nosync_mode>

No Sync Screen (Test Pattern) Color Setting

- ▶ SET•/MEDIA/VIDEO/<out>.NoSyncColor=<RGB_code>

HDCP Setting

- ▶ SET•/MEDIA/VIDEO/<out>.HdcpMode=<HDCP_mode>

Identify Stream / Identify Display

- ▶ CALL•/MEDIA/VIDEO/<out>:identify()

Querying the Source MUX Options

- ▶ GET•/MEDIA/VIDEO/<out>.SourceMuxOptions

Source MUX Setting

- ▶ SET•/MEDIA/VIDEO/<out>.SourceMux=<in|out>

Audio Port Settings**Query the Status of Source Port**

- ▶ GET•/MEDIA/AUDIO/XP.SourcePortStatus

Query the Status of Destination Port

- ▶ GET•/MEDIA/AUDIO/XP.DestinationPortStatus

Query the Audio Crosspoint Setting

- ▶ GET•/MEDIA/AUDIO/XP.DestinationConnectionList

Audio Stream Switching

- ▶ CALL•/MEDIA/AUDIO/XP:switch(<source>:<destination>)

Switching a Stream to All Destinations

- ▶ CALL•/MEDIA/AUDIO/XP:switchAll(<source>)

Enable/Disable the Audio Stream

- ▶ SET•/MEDIA/AUDIO/<source|destination>.Enabled=true|false

Analog Audio Port Settings**Setting the Volume in dB**

- ▶ SET•/MEDIA/AUDIO/<in|out>.VolumedB=<volume>

Setting the Volume in Percent

- ▶ SET•/MEDIA/AUDIO/<in|out>.VolumePercent=<percent>

Setting the Balance

- ▶ SET•/MEDIA/AUDIO/<in|out>.Balance=<balance>

Setting the Gain

- ▶ SET•/MEDIA/AUDIO/<in>.Gain=<gain>

Mute/Unmute the Analog Audio Output Port

- ▶ SET•/MEDIA/AUDIO/<out>.Mute=<logical_value>

System Monitoring Commands**Query Connected Device Presence**

- ▶ GET•/MEDIA/VIDEO/<in|out>.Connected

Query Video Signal Presence

- ▶ GET•/MEDIA/VIDEO/<in|out|source|destination>.SignalPresent

Query Embedded Audio Presence

- ▶ GET•/MEDIA/VIDEO/<in|out|source|destination>.EmbeddedAudioPresent

Query the Status of the Analog Audio Output

- ▶ GET•/MEDIA/AUDIO/<out>.MuteStatus

Query the Signal Type

- ▶ GET•/MEDIA/VIDEO/<source|destination>.SignalType

Query the Resolution of the Stream

- ▶ GET•/MEDIA/VIDEO/<source|destination>.Resolution

Query the Bandwidth of the Stream

- ▶ GET•/MEDIA/VIDEO/<source|destination>.Bandwidth

Query the Bandwidth Limitation Indicator

- ▶ GET•/MEDIA/VIDEO/<source|destination>.BandwidthLimitExceeded

Query the Link Aggregation Status

- ▶ GET•/SYS/MB/UPLINK/<link>.LinkState

SFP+ Module Information

Query the Vendor

- ▶ GET•/SYS/MB/UPLINK/<link>/SFP.VendorName

Query the Part Number

- ▶ GET•/SYS/MB/UPLINK/<link>/SFP.PartNumber

Query the Compliance

- ▶ GET•/SYS/MB/UPLINK/<link>/SFP.Compliance

Query the Maximum Allowed Cable Length

- ▶ GET•/SYS/MB/UPLINK/<link>/SFP.MaxLinkLength

Query the Type of the Module

- ▶ GET•/SYS/MB/UPLINK/<link>/SFP.Type

Query the Compatibility of the Module

- ▶ GET•/SYS/MB/UPLINK/<link>/SFP.Compatible

EDID Management

Query the Emulated EDIDs

- ▶ GET•/EDID.EdidStatus

Query the Validity of a Dynamic EDID

- ▶ GET•/EDID/D/<dynamic>.Validity

Query the Preferred Resolution of a User EDID

- ▶ GET•/EDID/U/<user>.PreferredResolution

Emulating an EDID on an Input Port

- ▶ CALL•/EDID:switch(<dynamic|user|factory>:<emulated>)

Copy an EDID to User Memory

- ▶ CALL•/EDID:copy(<dynamic|emulated|factory|user>:<user>)

Deleting an EDID from User Memory

- ▶ CALL•/EDID:delete(<user>)

Resetting the Emulated EDIDs

- ▶ CALL•/EDID:reset()

Network Configuration

Query the DHCP State

- ▶ GET•/MANAGEMENT/NETWORK.DhcpEnabled

Change the DHCP State

- ▶ SET•/MANAGEMENT/NETWORK.DhcpEnabled=<logical_value>

Query the MAC Address

- ▶ GET•/MANAGEMENT/NETWORK.MacAddress

Query the IP Address

- ▶ GET•/MANAGEMENT/NETWORK.IpAddress

Change the IP Address (Static)

- ▶ SET•/MANAGEMENT/NETWORK.StaticIpAddress=<IP_address>

Query the Subnet Mask

- ▶ GET•/MANAGEMENT/NETWORK.NetworkMask

Change the Subnet Mask (Static)

- ▶ SET•/MANAGEMENT/NETWORK.StaticNetworkMask=<netmask>

Query the Gateway Address

- ▶ GET•/MANAGEMENT/NETWORK.GatewayAddress

Change the Gateway Address (Static)

- ▶ SET•/MANAGEMENT/NETWORK.StaticGatewayAddress=<gw_address>

Apply Network Settings

- ▶ CALL•/MANAGEMENT/NETWORK:ApplySettings()

Query the IP Address of the Remote Endpoint

- ▶ GET•/REMOTE.RemoteIpAddress

RS-232 Port Configuration

Query the Current Configuration

- ▶ GET•/MEDIA/UART/<port>.Rs232Configuration

BAUD Rate Setting

- ▶ SET•/MEDIA/UART/<port>.Baudrate=<number>

Parity Setting

- ▶ SET•/MEDIA/UART/<port>.Parity=<number>

Stopbits Setting

- ▶ SET•/MEDIA/UART/<port>.StopBits=<number>

Databits Setting

- ▶ SET·/MEDIA/UART/<port>.DataBits=<number>

Command Injection TCP Port Setting

- ▶ SET·/MEDIA/UART/<port>.CommandInjectionPort=<port>

Infrared Port Configuration**Enable/Disable the Port**

- ▶ SET·/MEDIA/IR/<in|out>.Enable=<logical_value>

Enable Command Injection

- ▶ SET·/MEDIA/IR/<in|out>.CommandInjectionEnable=<logical_value>

Change Command Injection Port Number

- ▶ SET·/MEDIA/IR/<in|out>.CommandInjectionPort=<port_no>

Enable/Disable Output Signal Modulation

- ▶ SET·/MEDIA/IR/<out>.EnableModulation=<logical_value>

Message Sending via Communication Ports**Sending a Text (ASCII-format) via Serial Port**

- ▶ CALL·/MEDIA/UART/<port>:sendText(<message>)

Sending a Binary Message (HEX-format) via Serial Port

- ▶ CALL·/MEDIA/UART/<port>:sendBinaryMessage(<message>)

Sending a Message (ASCII-format) via Serial Port

- ▶ CALL·/MEDIA/UART/<port>:sendMessage(<message>)

Sending Hex Codes in Little-endian Format via IR Port

- ▶ CALL·/MEDIA/IR/<out>:sendProntoHex(<hex_code>)

Sending Hex Codes in Big-endian Format via IR Port

- ▶ CALL·/MEDIA/IR/<out>:sendProntoHexBigEndian(<hex_code>)

USB K+M Settings (F120 / F121 Models)**Switching the Emulated Port to the Remote Receiver**

- ▶ CALL·/MEDIA/KM/XP:switch(<e>:<r>)

Switching the Local Emulated Port to the Local Receiver

- ▶ CALL·/MEDIA/KM/XP:switch(<eN>:<rN>)

Disconnecting the Receiver Port

- ▶ CALL·/MEDIA/KM/XP:switch(0:<r>)

Enable/Disable the Receiver Port

- ▶ SET·/MEDIA/KM/<u>.Enabled

Querying the Presence of the USB-A Device

- ▶ GET·/MEDIA/KM/<d>.DevicePresent

Querying the Product Name of the USB-A Device

- ▶ GET·/MEDIA/KM/<d>.Product

Querying the Manufacturer of the USB-A Device

- ▶ GET·/MEDIA/KM/<d>.Manufacturer

Querying the Serial Number of the USB-A Device

- ▶ GET·/MEDIA/KM/<d>.Serial

Querying the Device Class of the USB-A Device

- ▶ GET·/MEDIA/KM/<d>.DeviceClass

Querying the Interface Classes of the USB-A Device

- ▶ GET·/MEDIA/KM/<d>.InterfaceClasses

Enable/Disable Power Sending of the USB-A Port

- ▶ SET·/MEDIA/KM/<d>.Power

Enable/Disable Suspending of the USB-A Port

- ▶ SET·/MEDIA/KM/<d>.Suspend

USB KVM Settings (F130 Model)**Setting the Operation Mode of the Icron USB 2.0 Module**

- ▶ SET·/MANAGEMENT/ICRON.OperationMode=<operation_mode>

Querying the MAC Address of the Icron Module

- ▶ GET·/MANAGEMENT/ICRON.MacAddress

Querying the IP Address of the Icron Module

- ▶ GET·/MANAGEMENT/ICRON.IpAddress

Switching the Emulated Port to the Remote Receiver

- ▶ CALL·/MEDIA/KM/XP:switch(<e>:<r>)

Switching the Local Emulated Port to the Local Receiver

- ▶ CALL·/MEDIA/KM/XP:switch(<eN>:<rN>)

Disconnecting the Receiver Port

- ▶ CALL·/MEDIA/KM/XP:switch(0:<r>)

Enable/Disable the Receiver Port

- ▶ SET·/MEDIA/KM/<u>.Enabled

Querying the Presence of the USB HID Device

- ▶ GET·/MEDIA/KM/<d>.DevicePresent

Querying the Product Name of the USB HID Device

- ▶ GET·/MEDIA/KM/<d>.Product

Querying the Manufacturer of the USB HID Device

- ▶ GET·/MEDIA/KM/<d>.Manufacturer

Querying the Serial Number of the USB HID Device

- ▶ GET·/MEDIA/KM/<d>.Serial

Querying the Device Class of the USB HID Device

- ▶ GET·/MEDIA/KM/<d>.DeviceClass

Querying the Interface Classes of the USB HID Device

- ▶ GET·/MEDIA/KM/<d>.InterfaceClasses

Enable/Disable Power Sending of the USB HID Port

- ▶ SET·/MEDIA/KM/<d>.Power=<logical_value>

Enable/Disable Suspending of the USB HID Port

- ▶ SET·/MEDIA/KM/<d>.Suspend=<logical_value>

8

Switchable USB Command Protocol

The Icron USB module of the F130 models can be controlled by a computer via UDP commands. This chapter is related to the UBEX-PRO20-HDMI-F130 variant only.

- ▶ Instructions for the Terminal Application Usage 172
- ▶ Setup 172
- ▶ Protocol Description 173
- ▶ Network Broadcast 173
- ▶ Generic Replies 174
- ▶ Supported Messages 174

DIFFERENCE: This chapter is related to the UBEX-PRO20-HDMI-F130 model only.

8.1. Instructions for the Terminal Application Usage

Terminal Application

The UDP protocol commands can be applied to the extenders using a terminal application. You need to install one of them on your control device, for example YAT. `#terminal`

Establishing Connection

Follow the steps to establish connection to the F130 model:

- Step 1.** Connect the receiver to a LAN over Ethernet.
- Step 2.** Open the terminal application (e.g. YAT).
- Step 3.** Go to Terminal > Settings.
- Step 4.** Select the **Binary** terminal type.
- Step 5.** Select the **UDP/IP Client** port type.
- Step 6.** Add the **IP address** of the device (eg: 192.168.0.125) and the **Remote UDP port number (6137)**.
- Step 7.** In View > Radix, choose **Hexadecimal**.
- Step 8.** Open the connection.

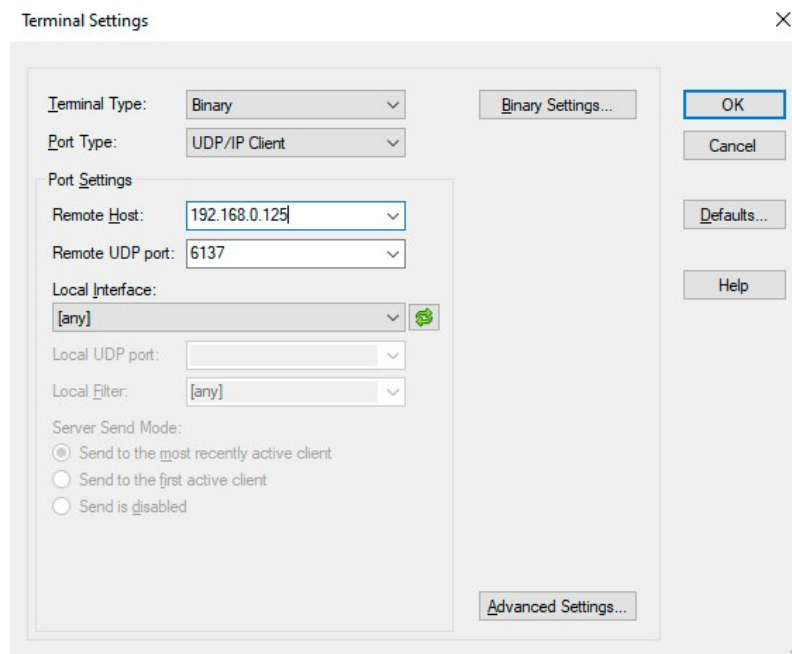

Terminal settings window of the YAT terminal application

Once the terminal window is opened, you can enter the UDP protocol commands, which are listed in the following sections:

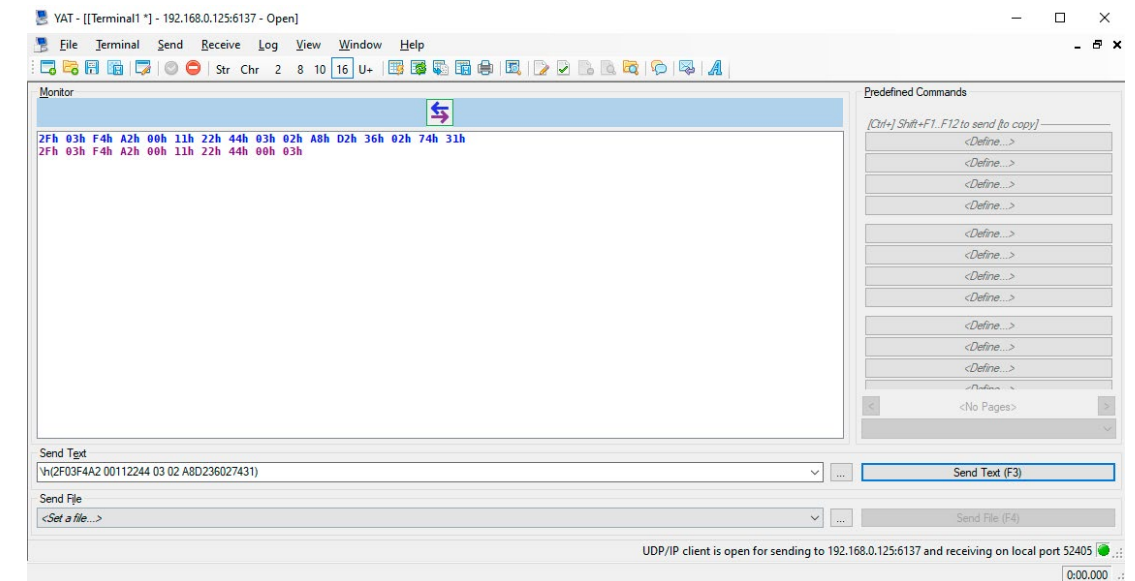

YAT terminal window

The format of a hexadecimal command in YAT is the following:

\h(<UDP_command>)

8.2. Setup

Before you begin configuration, please make sure of the following:

- Step 1.** Take note of the **MAC address** of your devices. You can find this information in the lower left corner of the top of the extenders.
- Step 2.** Connect your extenders to each other (point-to-point mode) or the switch (virtual hub in host-side extender).
- Step 3.** Connect your host-side extender to the host computer via a USB cable.
- Step 4.** Check that your host (or control) computer is in the same network as your extenders.
- Step 5.** Power on your devices.
- Step 6.** Pair the extenders with the [Pairing to a Device](#) message.

8.3. Protocol Description

The SwitchableUSB: Device Configuration Network Protocol described in this chapter works on top of User Datagram Protocol (UDP). The protocol is created to be able to discover and configure Icron modules on a local Ethernet network. The messages can be sent to the device as UDP packages via port no. 6137. In the following examples the packages are sent in Hexadecimal format.

Generic Packet Structure

Format	Explanation
Magic Number	A value (0x2F03F4A2) that ensures that the following data is a configuration message.
Message ID	When the client sends a request, it chooses any value to insert in this field. The extender responding to the request will set this field in the reply to the same value.
Protocol Version	An integer from 0-255. All devices will support protocol 0 and one other protocol version. The Replying Device Information message will inform the client which version of the protocol it must speak in order to communicate with the extender.
Command	An integer from 0-255. This is the identifier of the command. The combination of the protocol version and the command identify a unique message type.

- All multi-byte fields are packed as big endian.
- Messages are at least 10 bytes and at most 136 bytes in length.
- Any string fields should be encoded using UTF-8.

Example

⚡ 2F03F4A2 00112244 00 00

8.3.1. Legend for the Commands

Format	Description
➡	Sent request
⬅	Received response

INFO: Spaces seen in the examples are for enhancing readability, they can be left out of the commands.

8.4. Network Broadcast

8.4.1. Subnet Broadcast

To broadcast a packet to subnet you only have to use the broadcast IP of the subnet. For example to broadcast to a network configured as an IP range of 192.168.5.xxx, and a netmask of 255.255.255.0, the IP 192.168.5.255 is the broadcast IP address. In case of a network configured as an IP range of 10.xxx.xxx.xxx, and a netmask of 255.0.0.0, the IP 10.255.255.255 is the broadcast IP address.

Since routers drop broadcast IP packets with a destination outside of the network of the source, these broadcast packages must originate in the same network as the target devices.

8.4.2. All Local Subnet Broadcast

By broadcasting to the IP address 255.255.255.255 a broadcast packet can be sent out without knowing previously what the local network is. Microsoft Windows will, however, only send the packet out through the first configured network interface, so on a computer with multiple interfaces, each interface should send a separate broadcast network packet.

8.4.3. Mismatched Network Configuration

When broadcasting to a subnet using the network broadcast address (e.g. 192.168.5.255) and the extender is configured for a different network (e.g. IP=10.0.9.23 and netmask=255.0.0.0), the extender will not respond to the broadcast, as it will not recognize the IP address as a valid broadcast.

This should not happen when a proper DHCP server allocates addresses from the same pool for the network, however, it may happen when assigning static IP addresses or moving units between networks. In case of this occurrence, the extender must be reset to a DHCP address in the way seen in the section [Using DHCP](#). After this a static IP address can be assigned to the unit again.

8.5. Generic Replies

8.5.1. Acknowledge

This message is a generic ACK message that will be sent in response to all requests made by clients that do not require returning an additional data payload in the response. The **Message ID** field should be sufficient to determine which message is being acknowledged.

Byte Offset	
0	Magic Number
2	
4	Message ID
6	
8	Protocol Version = 0 Command = 3

Example

☛ 2F03F4A2 00112244 00 03

8.5.2. Negative Acknowledge

This message is a generic NAK message that may be sent in response to a **Pairing to a Device, Removing Device Pairing** or **Requesting Device Topology** message. It indicates to the client that their request was received, but that no action will be taken as a result of that message. The Message ID field should be sufficient to determine which message this is a response to.

Byte Offset	
0	Magic Number
2	
4	Message ID
6	
8	Protocol Version = 3 Command = 8

Example

☛ 2F03F4A2 00112244 03 08

8.6. Supported Messages

8.6.1. Requesting and Replying Device Information

Request

This message is sent from the client to an extender in order to evoke a **Replying Device Information** message. This message can be sent in a broadcast UDP message in order to discover all of the configurable USB extenders on the local network.

Byte Offset	
0	Magic Number
2	
4	Message ID
6	
8	Protocol Version = 0 Command = 0

Reply

This message is sent from an extender to a client in response to a **Requesting Device Information** message.

Byte Offset	
0	Magic Number
2	
4	Message ID
6	
8	Protocol Version = 0 Command = 1
10	MAC Address
12	
14	
16	IP Address
18	
20	Network Aquisition Mode Supported Protocol Version
22	Vendor
	⋮
52	
54	Product
	⋮
84	
86	Revision
	⋮
96	

Field Descriptions

Field Data Type	Explanation	Values	Value description
MAC address	The MAC address of the device		
IP address	The current IP address of the device		
Network Acquisition Mode		0 1	DHCP Static
Supported Protocol Version	This number specifies what protocol version the device supports beside protocol 0.		
Vendor	A 32-byte, NUL-terminated string containing the vendor name of the device.		
Product	A 32-byte, NUL-terminated string containing the product name of the device.		
Revision	A 12-byte, NUL-terminated string containing the revision number of the device.		

Example

```

⚡ 2F03F4A2 00112244 00 00
🕒 2F03F4A2 00112244 00 01 A8D236027431 C0A8007D 00 03
4C69676874776172652056697375616C20456E67696E656572696E6700000000
55534232302D314742452D4853313000000000000000000000000000000000
322E302E360000000000000000

```

8.6.2. Ping

This message is sent from a client to the device to check if a device is active. An **Acknowledge** message will be sent by the device in response.

Request

Byte Offset

0	Magic Number	
2		
4	Message ID	
6		
8	Protocol Version = 0	Command = 2

Example

```

⚡ 2F03F4A2 00112244 00 02
🕒 2F03F4A2 00112244 00 03

```

8.6.3. Requesting and Replying Extended Device Information

Request

Sent by a client to an extender in order to obtain additional information about the device that is not included in the **Replying Device Information** message from protocol 0.

Byte Offset

0	Magic Number	
2		
4	Message ID	
6		
8	Protocol Version = 3	Command = 0

Reply

Sent by an extender to a client in response to a **Requesting Extended Device Information** message.

Byte Offset

0	Magic Number	
2		
4	Message ID	
6		
8	Protocol Version = 3	Command = 1
10	LEX/REX	Paired with MAC address
12		
14		
16		

Last six bytes can be repeated 0 or 1 times for an extender in point-to-point mode, or 0 to 7 times for a host side extender with virtual hub enabled.

Field Descriptions

Field Data Type	Explanation	Values	Value description
LEX/REX	This determines whether the responding device is a host-side extender (LEX), or a device-side extender (REX).	0 1	Host-side extender Device-side extender
Paired with MAC address	MAC address of an extender that this device is paired with. This field is optional and may be repeated up to 7 times.		

Example

```

⚡ 2F03F4A2 00112244 03 00
🕒 2F03F4A2 00112244 03 01 00 A8D23602B357001B1302E3A4

```

8.6.4. Pairing to a Device

This message is sent by a client to instruct an extender to try to pair with a different extender specified in the message. The client must send this message to both the host-side and device-side extenders, the contents adjusted respectively, but the order of the two messages does not matter. The extender will respond with an **Acknowledge** message if it is able to pair with a new device or a **Negative Acknowledge** message otherwise. These replies only mean that an attempt will be made to establish a link between the extenders, not that a link is already established. #pairing

In case of pairing several device-side extenders to a host-side extender, this step must be repeated for each pairing. #pairing

Field Descriptions

Field Data Type	Explanation	Values	Value description
Pairing to device MAC address	The MAC address that the client is telling the extender to attempt to pair with.		

Request

Byte Offset	Field
0	Magic Number
2	
4	Message ID
6	
8	Protocol Version = 3 Command = 2
10	Pairing to Device MAC Address
12	
14	

Example

```
⚡ 2F03F4A2 00112244 03 02 A8D236027431
🕒 2F03F4A2 00112244 00 03
```

```
⚡ 2F03F4A2 00112244 03 02 A8D23602B357
🕒 2F03F4A2 00112244 00 03
```

8.6.5. Removing Device Pairing

Sent by a client to an extender, instructing it to discard any existing pairing it has. This will effectively disconnect any USB devices that were downstream of the remote extender. The client must send this message to each of the extenders in the pairing. The extenders will respond with an **Acknowledge** message or with a **Negative Acknowledge** if it is already unpaired or paired to a different extender.

Field Descriptions

Field Data Type	Explanation	Values	Value description
Paired MAC address	The MAC address that the client is telling the extender to disassociate from.		

Request

Byte Offset	Field
0	Magic Number
2	
4	Message ID
6	
8	Protocol Version = 3 Command = 3
10	Paired MAC Address
12	
14	

Example

```
⚡ 2F03F4A2 00112244 03 03 A8D236027431
🕒 2F03F4A2 00112244 00 03
```

```
⚡ 2F03F4A2 00112244 03 03 A8D23602B357
🕒 2F03F4A2 00112244 00 03
```

8.6.6. Requesting and Replying Device Topology

Request

Sent by a client to a host-side extender in order to obtain the set of USB devices in the system. A device-side extender will respond with a **Negative Acknowledge** to this message.

Byte Offset		
0	Magic Number	
2		
4	Message ID	
6		
8	Protocol Version = 3	Command = 4

Reply

A host-side extender will send this message in response to a **Requesting Device Topology** message. The length of this message varies depending on the number of devices in the system. The combination of the information is enough for a client to build and display a device tree.

Byte Offset		
0	Magic Number	
2		
4	Message ID	
6		
8	Protocol Version = 3	Command = 5
10	USB Address	USB Address Of Parent
12	Port on Parent	Is Device a Hub
14	USB Vendor ID	
16	USB Product ID	

Bytes 10 to 16 can be repeated 0 to 32 times according to the number of USB devices.

INFO: Maximum number of USB devices is 32.

Field Descriptions

Field Data Type	Explanation	Values	Value description
USB Address	An integer from 0 to 127.		
USB Address of Parent	An integer from 1 to 127. If a USB Address is seen that is not listed as the USB Address of Parent for any of the devices, then that device is the root of the device topology.		
Port on Parent	An integer from 1 to 127. 0 is not a valid number for a port on a hub, so this field will only be 0 if there is no USB device upstream before the host.		
Is Device a Hub		0 1	False True
USB Vendor ID	The USB Vendor ID from the device descriptor.		
USB Product ID	The USB Product ID from the device descriptor.		

Example

⚡ 2F03F4A2 00112244 03 04

🕒 2F03F4A2 00112244 03 05 2A27020004580186 2724010104B46506 24000001089D0001

8.6.7. Using DHCP

Sent by a client to an extender to tell it to use DHCP to obtain an IP address. This message may be sent either as a UDP broadcast packet or a packet directed to a specific IP address known already. Regardless of whether the message was sent as a broadcast or not, the device will only switch to DHCP mode if the Target MAC Address field matches its own MAC address. When a valid **Using DHCP** message is received, the extender will send an **Acknowledge** message before discarding its static address configuration and acquiring an IP address via DHCP. If the **Using DHCP** message is sent to a device already in DHCP mode, it will still send an **Acknowledge** response, but no further actions are taken such as IP renewal. The client is able to tell the mode an extender is in by inspecting the Network Acquisition Mode field of the **Replying Device Information** message. #dhcp

Request

Byte Offset	Field
0	Magic Number
2	
4	Message ID
6	
8	Protocol Version = 3 Command = 6
10	Target MAC Address
12	
14	

Field Descriptions

Field Data Type	Explanation
Target MAC address	The MAC address of the device that will be set to use DHCP to obtain an IP address.

Example

```
⚡ 2F03F4A2 00112244 03 06 A8D236027431
🕒 2F03F4A2 00112244 00 03
```

8.6.8. Using Static IP

Sent by a client to an extender to tell it to use the static network configuration contained in this message. The IP, subnet mask and default gateway, as well as the network configuration are stored in permanent storage, so the device will keep the same network configuration after being power cycled. Similarly to the **Using DHCP** message, this message can be broadcast or sent to a specific device. Given that the Target MAC Address field matches the MAC address of the device, it will always respond with an **Acknowledge** message. Sending a **Using Static IP** message to a device already in a static configuration will enable the client to change the IP, subnet mask or default gateway of the device.

Request

Byte Offset	Field
0	Magic Number
2	
4	Message ID
6	
8	Protocol Version = 3 Command = 7
10	Target MAC Address
12	
14	
16	IPv4 Address
18	
20	Subnet Mask
22	
24	Default Gateway
26	

Field Descriptions

Field Data Type	Explanation
Target MAC Address	The MAC address of the device that will be set to use static network configuration.
IPv4 Address	The IPv4 address being assigned to this device encoded as a 32-bit integer.
Subnet Mask	The subnet mask of the network the device is on.
Default Gateway	Sets the default gateway of the device.

Example

```
⚡ 2F03F4A2 00112244 03 07 001B1302E3A4 C0A8007E FFFFFFF0 C0A80001
🕒 2F03F4A2 00112244 00 03
```

8.6.9. Using Filtering Strategy

Sent by a client to an extender to set it to use a certain type of filtering strategy contained in the message. The filtering strategy denotes the type of devices to be filtered out by the extenders. An **Acknowledge** message will be sent back to the client if the extender supports device class filtering and a valid strategy was selected. Otherwise, a **Negative Acknowledge** will be sent to the client.

Field Descriptions

Field Data Type	Values	Value description
Filtering Strategy	0	Allow all devices
	1	Block all devices except HID and hub
	2	Block mass storage devices
	3	Block all devices except HID, hub and smartcard
	4	Block all devices except audio and vendor-specific

Request

Byte Offset	Field
0	Magic Number
2	
4	Message ID
6	
8	Protocol Version = 3
10	Filtering Strategy
	Command = 9

Example

⚡ 2F03F4A2 00112244 03 09 02
 ⌚ 2F03F4A2 00112244 00 03

8.6.10. Resetting Device

This message is sent from the client to the extender. Upon receiving this message, the device resets.

Request

Byte Offset	Field
0	Magic Number
2	
4	Message ID
6	
8	Protocol Version = 3
	Command = 12

Example

⚡ 2F03F4A2 00112244 03 0C
 ⌚ 2F03F4A2 00112244 00 03

8.6.11. Requesting and Replying Configuration Response Data

Request

This message is sent from the client to an extender in order to evoke a **Replying Configuration Response Data** message.

Byte Offset	Field
0	Magic Number
2	
4	Message ID
6	
8	Protocol Version = 3
	Command = 13

Reply

This message is sent from an extender to a client in response to a **Requesting Configuration Response Data** message.

Byte Offset	Field
0	Magic Number
2	
4	Message ID
6	
8	Protocol Version = 3
	Command = 14
10	High Speed Status
	MSA Status
12	Vhub Status
	Current Filter Status
14	IP Acquisition Mode
	Reserved
16	MAC Address

18		
20		
22	Reserved	
24	Paired with MAC Address	
		⋮
64		
66	Port Number	
68	IP Address	
70		
72	Subnet Mask	
74		
76	Default Gateway	
78		
80	DHCP Server	
82		
84	Number of Vhub Ports	Reserved
86	VID	
88	PID	
90	Brand ID	
92	Vendor	
		⋮
120		
122	Product	
		⋮
152		
154	Revision	
		⋮
166		

Field Descriptions

Field Data Type	Explanation	Values	Value description
High Speed		0 1	Disabled Enabled
MSA		0 1	Disabled Enabled
Vhub		0 1	Disabled Enabled
Current Filter Status		0 1 2 3 4	Allow all devices Block all devices except HID and hub Block mass storage devices Block all devices except HID, hub and smartcard Block all devices except audio and vendor-specific
IP Acquisition Mode		0 1	DHCP Static
Reserved	This field is reserved and is set to 0.		
MAC Address	The MAC address of the device.		
Paired with MAC Address	MAC address of an extender that this device is paired with. This field is optional and may be repeated up to 7 times.		
Port Number	The port number that this device is connected to.		
IP Address	The current IP address of the device.		
Subnet Mask	The subnet mask of the device.		
Default Gateway	The default gateway for the device.		
DHCP Server	The DHCP server of the device.		
Num of Vhub ports	The number of downstream ports of the device.		
VID	The Vendor ID of the device.		
PID	The Product ID of the device.		
Brand ID	The Brand ID of the device.	0	Non-vendor locked device
Vendor	A 32-byte NUL-terminated string containing the vendor name of the device.		
Product	A 32-byte NUL-terminated string containing the product name of the device.		
Revision	A 12-byte NUL-terminated string containing the revision number of the device.		

8.6.13. Removing All Pairings

This command is sent by the client to an extender to instruct it to clear all of its pairings. This message may be sent to an extender that has no current pairings, but it will have no effect.

Request

Byte Offset	
0	Magic Number
2	
4	Message ID
6	
8	Protocol Version = 3 Command = 17

Example

```
⚡ 2F03F4A2 00112244 03 11
📡 2F03F4A2 00112244 00 03
```

8.6.14. Force Pairing to Device

This command is sent by the client to an extender to instruct it to clear all of its existing pairings and then try to pair with a different extender specified in the message. The client must send this message to both a host-side extender and a device-side extender to instruct them to be paired together, but the order of the two messages does not matter. The extender will respond with an **Acknowledge** message if it is able to pair with a new device or a **Negative Acknowledge** otherwise. *#pairing*

INFO: The **Acknowledge** message only indicates an attempt will be made to establish a link between the extenders, not that a link is already established. *#pairing*

Field Descriptions

Field Data Type	Explanation
Force Pair to Device MAC Address	The MAC address that the client is telling the extender to attempt to pair with.

Request

Byte Offset	
0	Magic Number
2	
4	Message ID
6	
8	Protocol Version = 3 Command = 18
10	Force Pair to Device MAC Address
12	
14	

Example

```
⚡ 2F03F4A2 00112244 03 12 A8D23602B357
📡 2F03F4A2 00112244 00 03

⚡ 2F03F4A2 00112244 03 12 A8D236027431
📡 2F03F4A2 00112244 00 03
```

8.6.15. Resetting Force Pairing to Device

This command is the same as the **Force Pairing to Device** command, but it resets the system after the pairing with the other extender happens.

INFO: This command only works when sent to a host-side extender. When sent to a device-side extender, it will reset the device, but pairing will not happen.

Field Descriptions

Field Data Type	Explanation
Force Pair to Device MAC Address	The MAC address that the client is telling the extender to attempt to pair with.

Request

Byte Offset

0	Magic Number	
2		
4	Message ID	
6		
8	Protocol Version = 3	Command = 19
10	Force Pair to Device MAC Address	
12		
14		

Example

⚡ 2F03F4A2 00112244 03 13 A8D23602B357
 ⌚ 2F03F4A2 00112244 00 03

8.6.16. Writing the Extended Configuration Variable

This command writes the extended configuration variable. It is used to control the following configuration parameters:

- Simultaneous Users Interaction (SUI) and Mass Storage Acceleration (MSA)
- Enabling/Disabling DHCP option
- DCF configuration

The client will set the bit of configuration mask corresponding to which configuration variable they want to change and set the configuration variable as defined below in the field descriptions. The system will reset after a variable is set.

ATTENTION: Please be aware that while this command is packed as big endian, depending on the terminal application and the Operation System, it may be reversed by the application to display as little endian.

Field Descriptions

Field Data Type	Explanation	Values	Value description
Configuration Mask	This is a 16-bit mask, in which only the first 4 are used. The remaining are reserved and set to 0.	Bit 0	Change only SUI and MSA fields in the configuration variable.
		Bit 1	Enabling/Disabling the DHCP variable only
		Bit 2	Reserved, set to 0
		Bit 3	Control DCF
Configuration Variable	This is the 32 bits defined as it follows:		
	Simultaneous Users Interaction (SUI) and Mass Storage Acceleration (MSA) (2-bit field starting at bit 0)	0 1 2 3	SUI off, MSA off SUI on, MSA off SUI off, MSA on Not used
	Enabling/Disabling the DHCP option 60 (1-bit field, at bit 2)		
	Reserved, set to 0 (1-bit field, at bit 3)		
	Disabling DCF or Set DCF options - DCF configuration field (4-bit field, starting at bit 4)	0 1 2 3 4 5-15	Allow all devices (DCF disabled) DCF: Block all devices except HID and hub DCF: Block mass storage devices DCF: Block all devices except HID, hub and smartcard DCF: Block all devices except audio and vendor-specific Reserved for future use

Request

Byte Offset	
0	Magic Number
2	
4	Message ID
6	
8	Protocol Version = 3 Command = 50
10	Configuration Mask
12	Extended Configuration Variable
14	

Example

⚡ 2F03F4A2 00112244 03 32 0100 01000000

🕒 2F03F4A2 00112244 00 03

INFO: Please take note that depending on the SUI setting, the extender may take up several USB tiers. If SUI is turned off, the extender takes up one USB tier. If SUI is turned on, it takes up two USB tiers. For optimal operation please make sure you do not exceed the maximum tier level (generally 7).

8.6.17. Requesting the Extended Configuration Variable**Request**

This command is sent from the client to the extender to request the extended configuration variable.

Byte Offset	
0	Magic Number
2	
4	Message ID
6	
8	Protocol Version = 3 Command = 51

Reply

This command is a response to the **Requesting Extended Configuration Variable** command, sent from the extender to the client. It offers the extended configuration variable.

Byte Offset	
0	Magic Number
2	
4	Message ID
6	
8	Protocol Version = 3 Command = 52
10	Extended Configuration Variable
12	

Field Descriptions

Field Data Type	Explanation	Values	Value description
Configuration Variable	This is the 32 bits defined as it follows:		
	Simultaneous Users Interaction (SUI) and Mass Storage Acceleration (MSA) (2-bit field starting at bit 0)	0	SUI off, MSA off
		1	SUI on, MSA off
		2	SUI off, MSA on
		3	Not used
	Enabling/Disabling the DHCP option 60 (1-bit field, at bit 2)		
	Reserved, set to 0 (1-bit field, at bit 3)		
	Disabling DCF or Set DCF options - DCF configuration field (4-bit field, starting at bit 4)	0	Allow all devices (DCF disabled)
		1	DCF: Block all devices except HID and hub
		2	DCF: Block mass storage devices
		3	DCF: Block all devices except HID, hub and smartcard
		4	DCF: Block all devices except audio and vendor-specific
		5-15	Reserved for future use

Example

⚡ 2F03F4A2 00112244 03 33

🔍 2F03F4A2 00112244 03 34 00000001

9

Firmware Update

The endpoint devices can be updated by using Lightware Device Updater v2 (LDU2) software via Ethernet. The firmware pack with the necessary components (*.lfp2 file) for your specific product, and the LDU2 application can be downloaded from the Support page of our website www.lightware.com.

- | | |
|-----------------------------------|-----|
| ▶ Preparation | 187 |
| ▶ Running the Software | 188 |
| ▶ The Updating Steps | 189 |
| ▶ Updating Via GUI | 190 |
| ▶ Command Line Interface (CLI) | 193 |
| ▶ CLI Commands | 193 |
| ▶ If the Update is not successful | 197 |

ATTENTION: After updating a main version of the UBEX endpoint firmware package (e.g. 2.x.x to v3.x.x), **downgrading is highly not recommended**. It may cause losing of settings and incompatibility issues with earlier backups.

ATTENTION: While the firmware is being updated, the normal operation mode is suspended, as the endpoint is switched to bootload mode. Signal processing is not performed. Do not interrupt the firmware update. If any problem occurs, reboot the receiver and restart the process.

ATTENTION: The firmware update process has an effect on the configuration and the settings of the device. For more details, please see the [Keeping the Configuration Settings](#) section before the update.

DIFFERENCE: Lightware highly recommends **using the same firmware versions** on the UBEX extender pairs. Connection between extenders installed with v3.0.0 and any earlier versions might cause unexpected performance failures.

9.1. Preparation

Most Lightware devices can be controlled over several interfaces (e.g. Ethernet, USB, RS-232). But the firmware can usually be updated over one dedicated interface, which is the Ethernet in most cases.

If you want to update the firmware of one or more devices you need the following:

- **LFP2 file**,
- **LDU2 software** installed on your PC or Mac.

Both can be downloaded from www.lightware.com.

Optionally, you can download the **release notes** file in HTML format.

9.1.1. About the Firmware Package (LFP2 File)

All the necessary tools and binary files are packed into the LFP2 package file. You need only this file to do the update on your device.

- This allows the use of the same LFP2 package for different devices.
- The package contains all the necessary components, binary, and other files.
- The release notes is included in the LFP2 file, which is displayed in the window where you select the firmware package file in LDU2.

9.1.2. LDU2 Installation

ATTENTION: Minimum system requirement: 2 GB RAM. The minimum screen resolution is 1600x900.

ATTENTION: Certain ports are used for the communication in the background; please check the list in the [Applied Ports \(Network Settings\)](#) section.

INFO: The Windows, Mac and Linux application has the same look and functionality.

Download the software from www.lightware.com.

Installation in case of Windows OS

Run the installer. If the User Account Control displays a pop-up message, click **Yes**.

Installation Modes

Normal install	Snapshot install
Available for Windows, macOS and Linux	Available for Windows only
The installer can update only this instance	Cannot be updated
One updateable instance may exist for all users	Many different versions can be installed for all users

ATTENTION: Using the default Normal install is highly recommended.

INFO: If you have a previously installed version, you will be prompted to remove the old version before installing the new one.

Installation in case of macOS

Mount the DMG file by double clicking on it, and drag the LDU2 icon over the Applications icon to copy the program into the Applications folder. If you want to copy LDU2 into another location, just drag the icon over the desired folder.

ATTENTION: Please check the firewall settings on the macOS device. LDC needs to be added to the exceptions of the blocked software for the proper operation.

INFO: This type of installer is equal to the **Normal install** of Windows.



Installation in case of Linux

Step 1. Download the **archive file** (tar.gz) from www.lightware.com and unpack it to a temp folder.

Step 2. Run the **install_ldu2.sh** file in the temp folder. The script will install LDU2 into the following folder: HOME/.local/share/lightware/ldu2.

Step 3. The folder above will contain this file: **LightwareDeviceUpdaterV2.sh** that can be used to start LDU2.

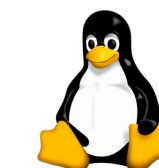

9.2. Running the Software

ATTENTION: The computer that runs LDU2 and the target device (that will be updated) must be in the same subnet. The update cannot be performed behind a firewall or gateway.

You have two options:

- **Starting the LDU2** by double-clicking on the shortcut/program file, or
- Double-clicking on an **LFP2 file**.

LDU2 Interfaces

The software can be used over:

- The Graphical User Interface (GUI), or by
- The Command Line Interface (CLI).

LDU2 Auto-Update

At startup, the software checks if a newer version is available on the web.

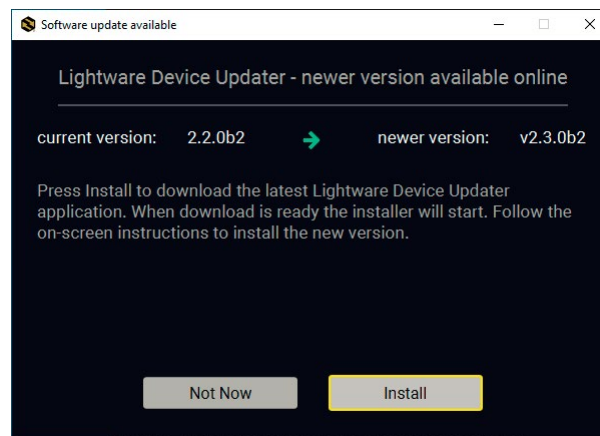

Main Screen

When the software is started by the shortcut, the device discovery screen appears. Press the **Discover Devices** button to start finding the Lightware devices:

DISCOVER DEVICES

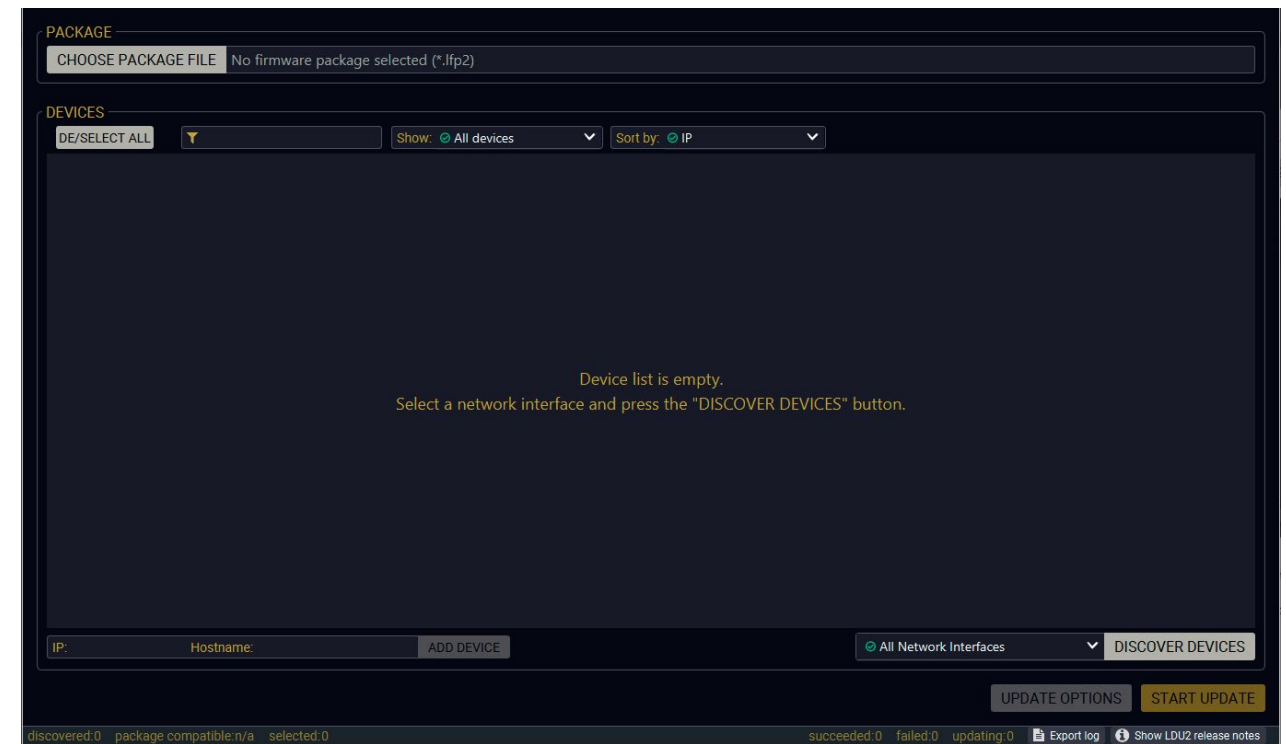

LDU2 welcome screen

If you start the software by double-clicking on the LFP2 file, the firmware will be loaded. Press the **Discover devices** button; all the devices will be listed that are compatible with the selected firmware pack.

INFO: If you press the **Choose package file** button, the release notes of the LFP2 file will be displayed in the right panel; see the [Step 1. Select the Firmware Package](#) section.

Device List





When the discovery has completed, the devices available on the network are listed in the application.

DE/SELECT ALL	Device Name	IP	S/N	PACKAGE	FW	HW
1.	UBEX-PRO20-HDMI-F100 UBEX-SGT_RJ45	169.254.214.207	B8218109	PACKAGE: v2.0.0b6	FW: v2.0.0b6	HW:
2.	MX2-24x24-DH-12DPI-A-R MX2-16x16-HDMI20-Audio-R	192.168.4.26	make_love_not_war	PACKAGE:	FW:	HW:
3.	UCX-4x2-HC30 LW_UCX-4x2-HC30_QA1895	192.168.4.94	QA1895	PACKAGE: v1.0.1b1	FW: v1.0.0b11	HW: V20_BAAX
4.	UCX-4x2-HC30D LW_UCX-4x2-HC30D_00006974	192.168.4.108	00006974	PACKAGE: v0.0.255b255	FW: v0.0.255b255	HW: V23_AXAX
5.	UCX-4x2-HC30 TRAINING_UCX-4x2-HC30_AC185932	192.168.4.164	AC185932	PACKAGE: v1.2.1b4	FW: v1.2.1b4	HW: V21_BAAX
6.	UCX-2x1-HC30 LW_UCX-2x1-HC30_00007126	192.168.4.217	00007126	PACKAGE: v0.0.255b255	FW: v0.0.255b255	HW: V20_AXAX
7.	UBEX-PRO20-HDMI-F100 UBEX-CAT_TX	192.168.4.230	B8218116	PACKAGE: v2.1.0b3	FW: v2.0.0b5	HW: V14_DAAX
8.	VINX-110-HDMI-DEC DEC-0011AAE80151	192.168.5.28	E80151	PACKAGE: v2.0.2b4	FW: v2.0.2b3	HW:
9.	HDMI20-OPTC-TX220-PRO HDMI20-OPTC-TX220-PRO	192.168.5.41	82115837	PACKAGE: v1.3.0b5	FW: v1.3.0b1	HW: V11_CAA0

If the desired device is not discovered, you can add it by typing the IP address or the host name in the dedicated field and pressing the **Add device** button.

ATTENTION: If the device cannot be added by the hostname, please use the IP address.

Legend of the Icons

-  **IP address editor** The IP address of the device can be changed in the pop-up window.
-  **Identify me** Clicking on the icon results in the front panel LEDs blinking for 10 seconds, which helps to identify the device physically.
-  **Favorite device** The device has been marked, thus the IP address is stored. When a device is connected with that IP address, the star will be highlighted in that line.
-  **Further information available** Device is unreachable. Change the IP address by pressing the **IP address editor** icon or use the front panel buttons (if available).
-  **Service mode** The device is in bootload mode. Backup and restore cannot be performed in this case.

9.3. The Updating Steps

ATTENTION: While the firmware is being updated, the normal operation mode is suspended, as the device is switched to bootload mode. Signal processing is not performed. Do not interrupt the firmware update. If any problem occurs, reboot the unit and restart the process.

Keeping the Configuration Settings

By default, device configuration settings are restored when firmware update is finished. If factory reset has been chosen in the parameters window, all device settings will be erased. In the case of factory reset, you can save the settings of the device in the Lightware Device Controller software and restore it later.

The following flow steps demonstrate how this function works in the background.

Step 1. Create a backup

The current configuration of the device is being saved into a configuration backup file on your computer.

Step 2. Start the Update

The device reboots and starts in bootload mode (firmware update mode).

Step 3. Upgrade

The CPU firmware is changed to the new one.

Step 4. Factory reset

All configuration settings are restored to the factory default values.

Step 5. Conversion / Restore

The firmware package checks the backup data before the restoration procedure, and if it is necessary, a conversion is applied to avoid incompatibility problems between the firmware versions. All configuration settings are restored to the device after the conversion.

If the factory default option is selected in the Parameters window, the conversion / restore procedure will not be performed!

Step 6. Finish

Once the firmware update procedure is finished, the device reboots and is ready to use.

9.3.1. The Correct Order of the Updating

It is important that the **remote device has to be updated first**, the local device that is connected to the computer directly has to be the second one.

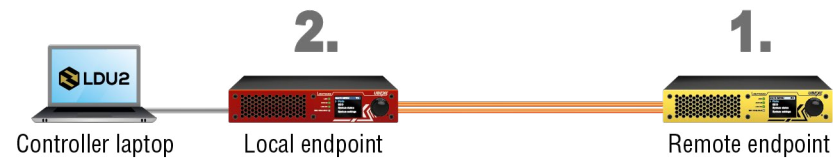

The sequence of the firmware update

9.3.2. The Steps of the Update in Quick Summary

- Step 1.** Select the firmware package file.
- Step 2.** Select the remote unit first for updating.
- Step 3.** Check the update parameters.
- Step 4.** Start the update and wait until it is finished.
- Step 5.** Wait until the unit reboots with the new firmware.
- Step 6.** Repeat the procedure with the local endpoint.

9.4. Updating Via GUI

Step 1. Select the Firmware Package

Click on the **Choose Firmware Package** button and navigate to the location where the LFP2 file of the UBEX endpoint is saved. When you click on the name of package, the preview of the release notes is displayed on the right side.

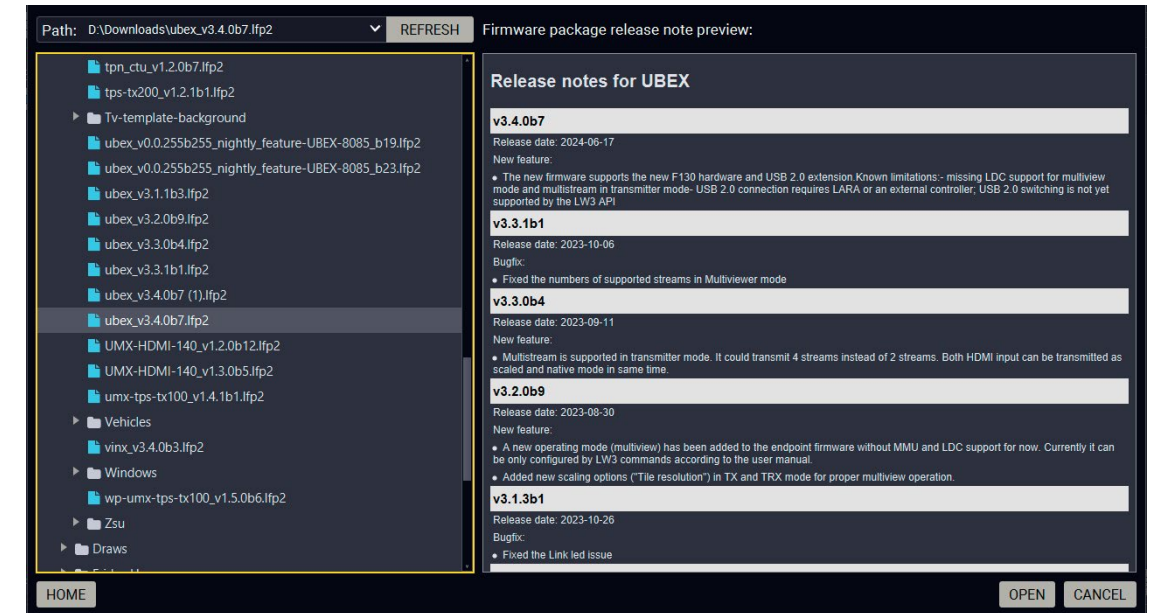

Firmware file browser and the release notes window

After the package file is loaded, the list is filtered to show compatible devices only. The current firmware version of the device is highlighted in orange if it is different from the version of the package loaded.

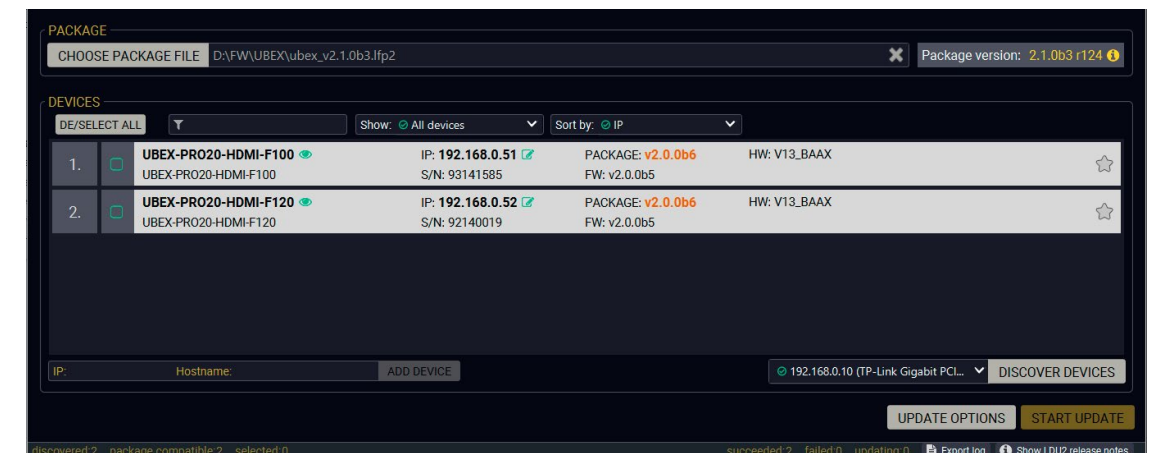

Filtered device list based on the selected firmware package

Step 2. Select the Remote Unit First for Updating

Pick the remote device for updating. The selected line will be highlighted in green.

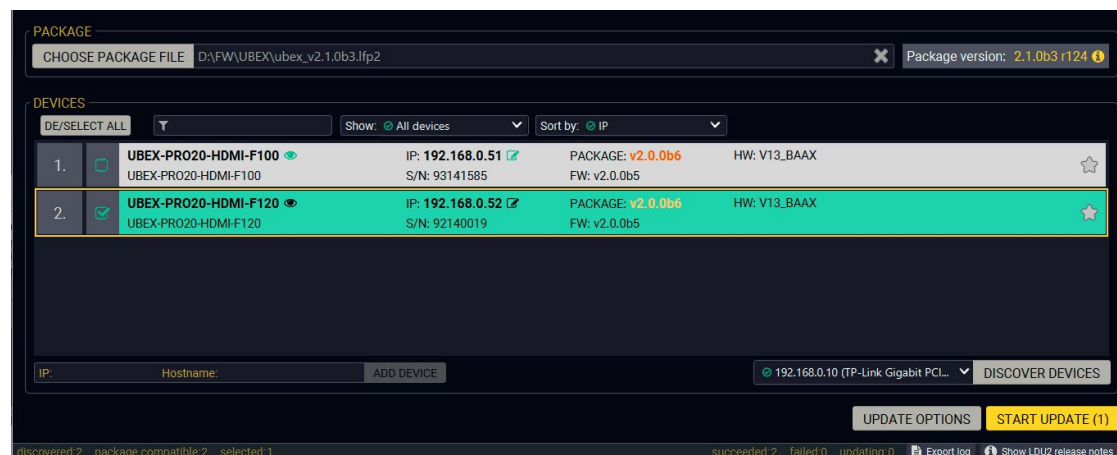

The remote unit is selected for updating

TIPS AND TRICKS: If you are not sure which device is connected to your controller device directly, use the **Identify me** feature clicking on the  button. It makes the four front panel LEDs blink in green for 10 seconds. The feature helps to identify the device itself in the rack shelf or on the desk.

Step 3. Check the Update Parameters.

ATTENTION: The default settings in the Parameters window should be fine for most cases. Please do not modify them if it is not necessary.

Click on the **Parameters** button to configure the firmware update.

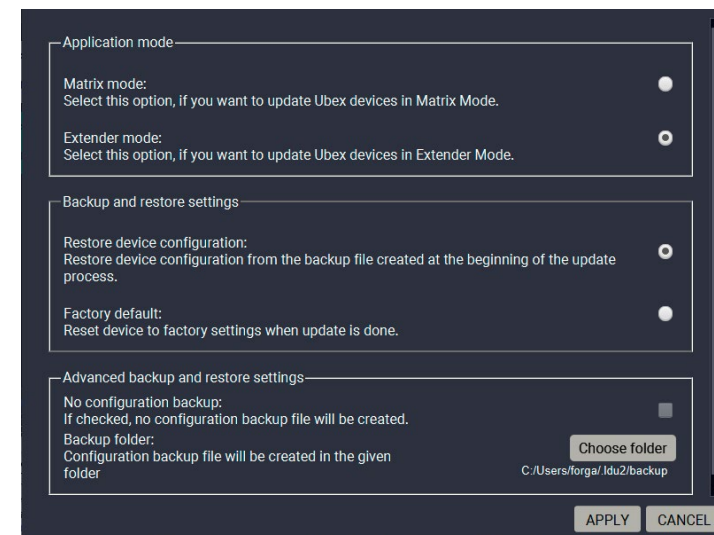

Parameters menu for the UBEX endpoints

Application Mode

The application mode (Extender or Matrix mode) of the current UBEX system can be selected in this section. Select the **Extender mode**.

See more details about the application modes in the [Application Modes](#) section.

Backup and Restore Settings

- **Restore device configuration:** the configuration settings of the endpoint devices will be restored after the firmware update.
- **Factory default:** if it is checked, all user settings and parameters will be cleared and the factory default settings will be applied to the device when the update is done. See the whole list of factory default settings of the endpoint device in the [Factory Default Settings](#) section.

Advanced Backup and Restore Settings

- **No configuration backup:** if it is checked, the configuration of the endpoint device will not be restored after the firmware update.
- **Backup folder:** Set the path of the device configuration backup file, which is created automatically. The default path is **USER_HOME/.Idu2/backup**.

Once the parameters are set, click on the **Apply** button to save the settings.

Step 4. Start the Update and Wait until It is Finished.

Click on the **Start Update** button to start the procedure.

The status is shown in percent in the right side of the device line and the status of all of the procedures is shown in the lower light green progress bar.

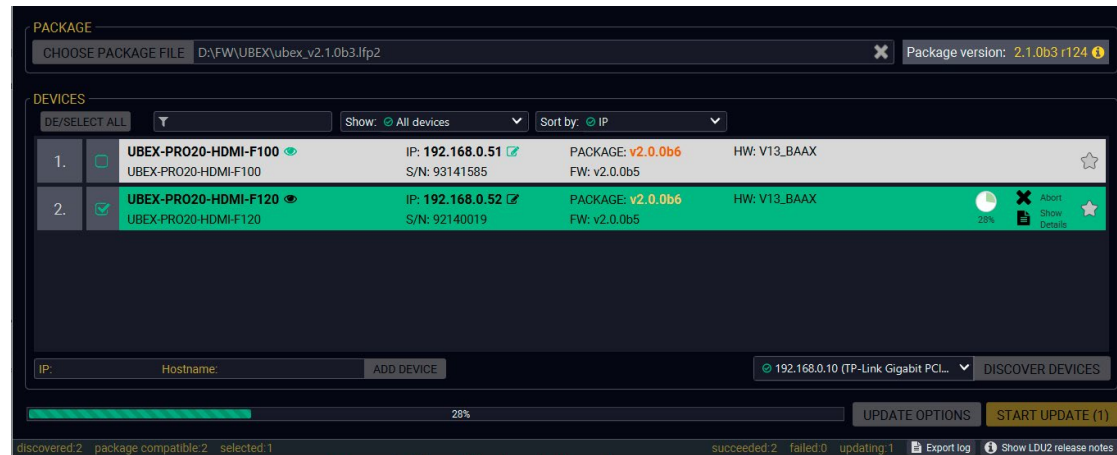

Firmware update is in progress

INFO: The device might reboot several times during the firmware update procedure.

Step 5. Wait until the Unit Reboots with the New Firmware.

Once the firmware update procedure is completed, the unit reboots with the new firmware.

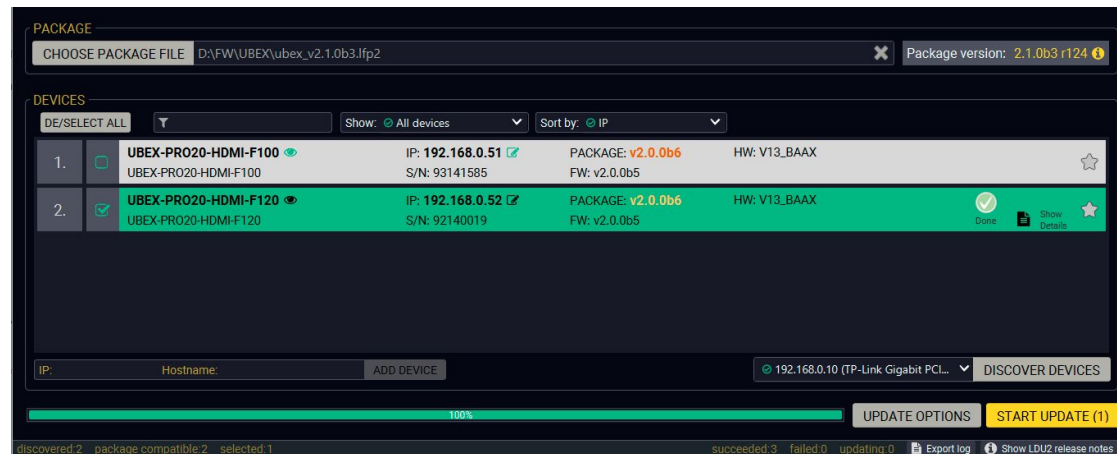

Firmware update procedure is done

Step 6. Repeat the Procedure with the Local Endpoint.

Repeat the whole procedure with the another endpoint.

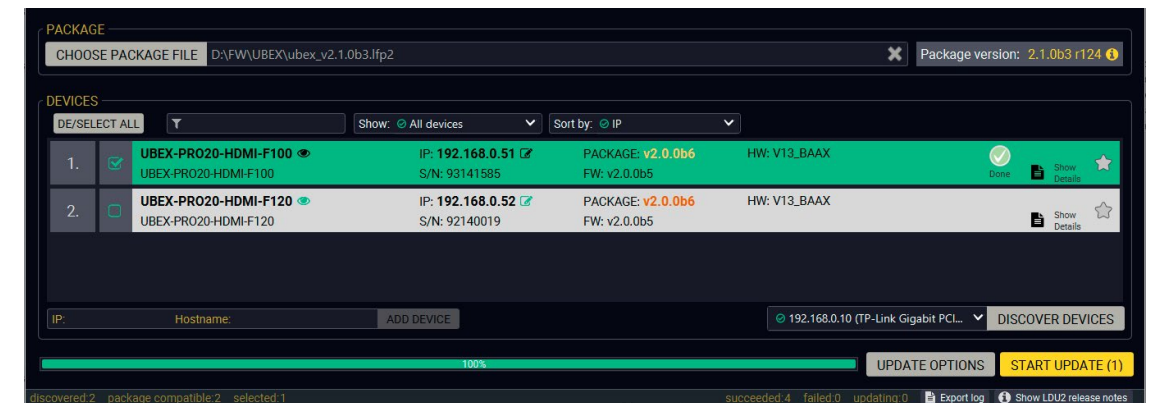
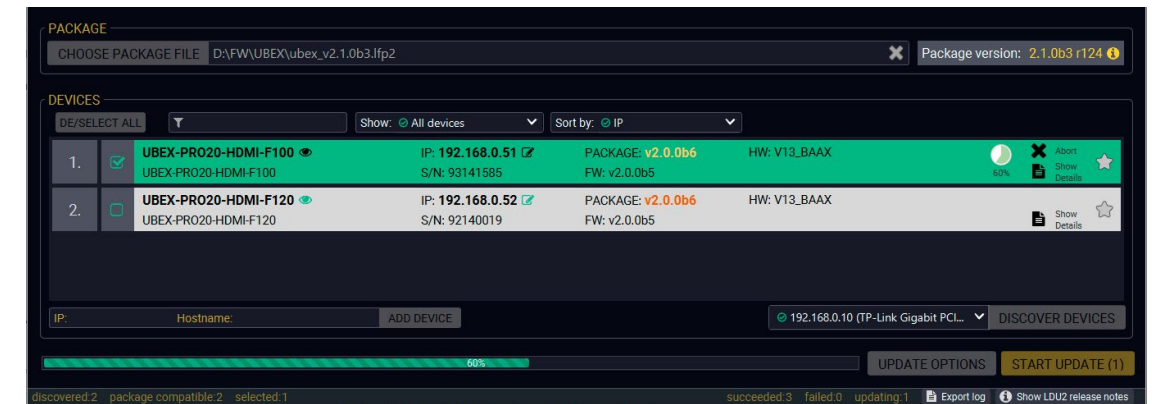
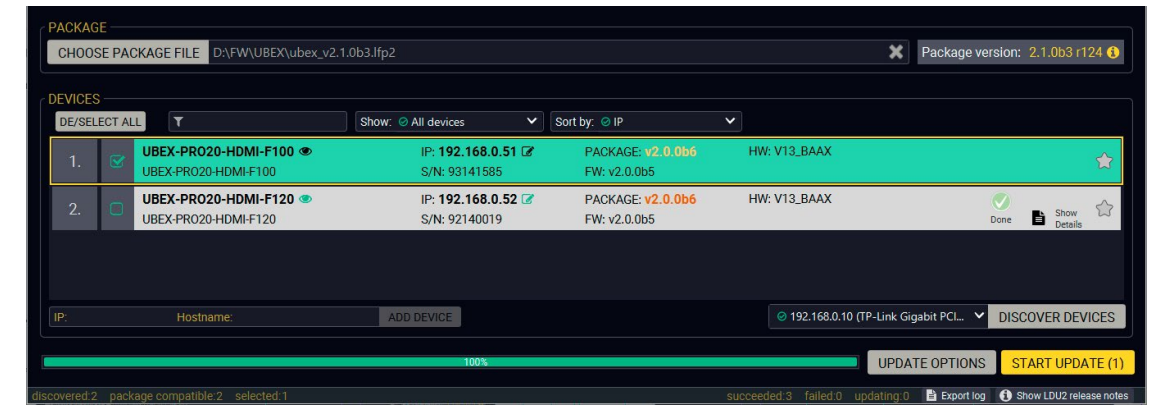

9.5. Command Line Interface (CLI)

DIFFERENCE: The Command Line Interface is available from **LDU2 v2.9.0b9**.

The CLI of the LDU2 software is a simple tool for creating scriptable device updates without the need of human interactions. It allows batch updating with the same features that are available in case of GUI usage.

9.5.1. How to Run

Running under Windows® OS

The installer of LDU2 puts the following file into the installation folder:

LightwareDeviceUpdaterV2_CLI.cmd

CLI is available via this file, the exe is not suitable for that purpose. Open a command line window to execute or test the features directly.

Step 1. Open an Explorer window where the cmd file is located, the default is:

`c:\Program Files (x86)\Lightware\Lightware Device Updater V2\LightwareDeviceUpdaterV2_CLI.cmd`.

Step 2. Click on the address line (highlighted with blue in the picture), type `cmd.exe` and press enter. The command interpreter window of Windows is opened at the path of the LDU2 install folder.

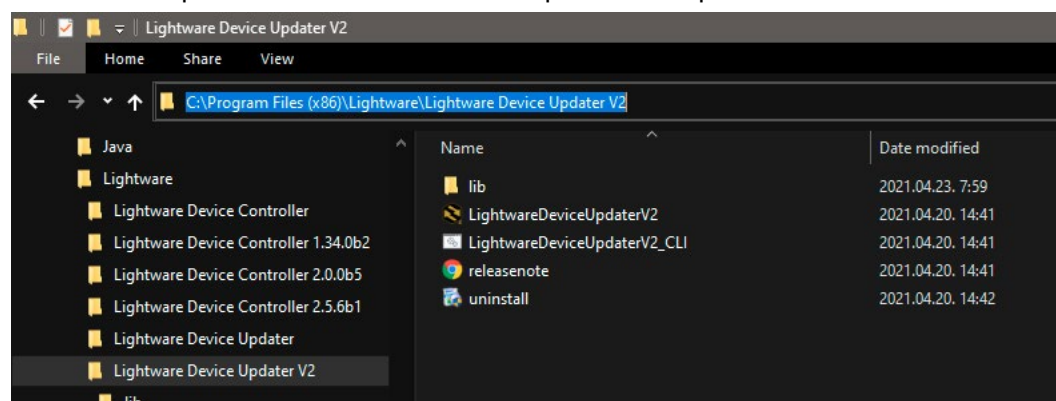

Step 3. Now you can use the `LightwareDeviceUpdaterV2_CLI.cmd` file with the commands and options, which are described in the coming sections:

Running under Linux

The Command Line Interface under Linux Operating Systems can be run by the following:

LightwareDeviceUpdaterV2.sh.

Running an update:

```
bash LightwareDeviceUpdaterV2.sh update --ip 172.24.5.27 --package ~/Downloads/ubex_v2.1.0b3.1fp2
```

The commands and options are the same under Windows® and Linux, too. Following sections contain examples with `LightwareDeviceUpdaterV2_CLI.cmd`.

9.5.2. How to Use

Command Structure

The commands can be run over CLI in the following way:

LightwareDeviceUpdaterV2_CLI.cmd [command] [options]

[Command]: a certain command described in the coming sections; only one command can be run at a time

[Options]: mandatory and/or optional parameters of the command, if any. Optional parameters have a default value, which can be found at each affected command. You only have to define the parameter if you want to apply a different value. The **order of the options** is arbitrary.

Important Notes

- CLI is **case-sensitive** (including commands, options and other parameters).
- There is **no limit** regarding the number of the devices to update. At most 20 devices are updated simultaneously, when one of them is finished, the following (21st) will be started automatically.
- If an update is failed, the IP address of the affected device(s) are listed at the end.

9.6. CLI Commands

INFO: The commands and options described in the following sections are the same under Windows® and Linux, too. The examples contain `LightwareDeviceUpdaterV2_CLI.cmd`.

About the Examples

- Sent command is in **blue**, response is in **grey**.
- If the response in practice is **longer than listed** in the example, this symbol can be seen: `[...]`.

9.6.1. Help

The defined commands and options can be listed by the `help` command.

Command

```
LightwareDeviceUpdaterV2_CLI.cmd help
```

Example

```
C:\Program Files (x86)\Lightware\Lightware Device Updater V2>LightwareDeviceUpdaterV2_CLI.cmd help

C:\Program Files (x86)\Lightware\Lightware Device Updater V2>lib\jre\bin\java.exe -jar lib\ldu2.jar help
Command line usage:
Win: LightwareDeviceUpdaterV2_CLI.cmd [command] [options]
Linux: LightwareDeviceUpdaterV2.sh [command] [options]

Commands:
* help
* version
* update
* deviceInfo
```

```
* restore
* packageOptions
[...]
```

9.6.2. LDU2 Version

The response shows the version of the LDU2 and the version of the Script API (the Application Programming Interface that is used by the LDU2 and the script).

Command

```
LightwareDeviceUpdaterV2_CLI.cmd version
```

Example

```
C:\Program Files (x86)\Lightware\Lightware Device Updater V2>LightwareDeviceUpdaterV2_CLI.cmd
version

C:\Program Files (x86)\Lightware\Lightware Device Updater V2>lib\jre\bin\java.exe -jar lib\
ldu2.jar version
LDU2 version: 2.9.0b9
Script API version: 1.3.9
```

9.6.3. Check For New LDU2 Version

The following command can be used to check if an update of LDU2 is available. This is just a request, since the CLI is not suitable for handling the complete installer of the software.

Command

```
LightwareDeviceUpdaterV2_CLI.cmd checkForUpdates
```

Example 1

```
c:\Program Files (x86)\Lightware\Lightware Device Updater V2>LightwareDeviceUpdaterV2_CLI.cmd
checkForUpdates

c:\Program Files (x86)\Lightware\Lightware Device Updater V2>lib\jre\bin\java.exe -jar lib\
ldu2.jar checkForUpdates
Current LDU2 version: 2.9.1b1
LDU2 is up-to-date
```

Example 2

```
c:\Program Files (x86)\Lightware\Lightware Device Updater V2>LightwareDeviceUpdaterV2_CLI.cmd
checkForUpdates

c:\Program Files (x86)\Lightware\Lightware Device Updater V2>lib\jre\bin\java.exe -jar lib\
ldu2.jar checkForUpdates
Current LDU2 version: 2.9.1b1
New version is available online: v2.9.2b2
Download URL: http://update.lightware.hu/ldu2/lwr/v2.9.2b2/install_LDU2_v2.9.2b2.exe
```

9.6.4. Device Info

The most important information about the selected device is displayed; see the example for more details.

Command

```
LightwareDeviceUpdaterV2_CLI.cmd deviceInfo [options]
```

Options

Option	Description	Required?
-i or --ip	List of IP addresses of devices to be updated	one of them is mandatory
-n or --hostName	List of host names of devices to be updated	mandatory
-v or --packageVersion	Shows installed package version only	optional

Example 1

```
C:\Program Files (x86)\Lightware\Lightware Device Updater V2>LightwareDeviceUpdaterV2_CLI.cmd
deviceInfo --ip 192.168.1.12

C:\Program Files (x86)\Lightware\Lightware Device Updater V2>lib\jre\bin\java.exe -jar lib\
ldu2.jar deviceInfo --ip 192.168.1.12
Product name: UBEX-PRO20-HDMI-F100
IP address: 192.168.1.12
Serial number: 00002263
MAC address: a8:d2:36:ff:22:63
Part number: 91540065
Device label: 123
Package version: v1.3.0b6
CPU FW version: v1.3.0b3
HW version: V12_KAA0
Operation mode: Application mode
```

Example 2

```
C:\Program Files (x86)\Lightware\Lightware Device Updater V2>LightwareDeviceUpdaterV2_CLI.cmd
deviceInfo --ip 192.168.1.12 --packageVersion

C:\Program Files (x86)\Lightware\Lightware Device Updater V2>lib\jre\bin\java.exe -jar lib\
ldu2.jar deviceInfo --ip 192.168.1.12 --packageVersion
v1.3.0b6
```

9.6.5. Update

This command can be used to update the firmware of the devices.

Command

```
LightwareDeviceUpdaterV2_CLI.cmd update [options]
```

Options

Option	Description	Required?
-p or --package	The path of the firmware package file	yes
-i or --ip	List of IP addresses of devices to be updated	one of them is mandatory
-n or --hostName	List of host names of devices to be updated	
-b or --backupFolder	Folder to create device configuration backup at. Default: USER_HOME/.ldu2/backup	optional
-f or --factoryDefault	Apply factory reset during device update. Default: false	optional
-r or --reportProgress	Report update progress in percentage form. Default: false	optional
Package-specific options	Certain LFP2 packages have features that can be applied at this command; see the Package Options section.	optional

ATTENTION: The configuration is restored automatically if the factory default option is not applied in the **update** command. In that case, there is no need to run the **restore** command after the update.

Example

```
C:\Program Files (x86)\Lightware\Lightware Device Updater V2>LightwareDeviceUpdaterV2_CLI.cmd
update --ip 192.168.1.12 --package C:\Firmwares\ubex_v2.1.0b3.lfp2 --reportProgress

C:\Program Files (x86)\Lightware\Lightware Device Updater V2>lib\jre\bin\java.exe -jar lib\ldu2.
jar update --ip 192.168.1.12 --package C:\Firmwares\ubex_v2.1.0b3.lfp2 --reportProgress
[2021-05-12 08:59:36.336] [ INFO] [          main] - Device IPs: [192.168.1.12]
[2021-05-12 08:59:39.409] [ INFO] [          main] - All the selected devices are accessible
over the network.
[2021-05-12 08:59:39.628] [ INFO] [          main] - All the selected devices are compatible
with the specified package.
[2021-05-12 08:59:40.025] [ INFO] [ 192.168.1.12] - Package version: 1.3.2b3
[2021-05-12 08:59:40.092] [ INFO] [ 192.168.1.12] - Login functionality is currently not
enabled.
[2021-05-12 08:59:40.129] [ INFO] [ 192.168.1.12] - Creating backup of device settings...
[2021-05-12 08:59:43.582] [ INFO] [ 192.168.1.12] - Backup HTTP enable properties
[2021-05-12 08:59:44.638] [ INFO] [ProgressReporter] - Progress: 2%
[2021-05-12 08:59:46.111] [ INFO] [ 192.168.1.12] - HTTP and HTTP post have got enabled on
port 80
[2021-05-12 08:59:46.319] [ INFO] [ 192.168.1.12] - No miniweb file is found on the device.
[2021-05-12 08:59:48.890] [ INFO] [ 192.168.1.12] - HTTP and HTTP post properties have got
restored on port 80
[2021-05-12 08:59:48.897] [ INFO] [ 192.168.1.12] - Switching device into bootload mode...
[2021-05-12 08:59:49.640] [ INFO] [ProgressReporter] - Progress: 5%
[...]
```

The lines containing "ProgressReporter" can be enabled optionally. If it is enabled, the current state is displayed every 5 seconds.

9.6.6. Restore

Restores device configuration from a backup file.

TIPS AND TRICKS: This command can be used for uploading a configuration to numerous devices (aka Configuration cloning by CLI).

Command

```
LightwareDeviceUpdaterV2_CLI.cmd restore [options]
```

Options

Option	Description	Required?
-i or --ip	List of IP addresses of devices to be updated	one of them is mandatory
-n or --hostName	List of host names of devices to be updated	
-b or --backupFile	The path of the configuration backup file	yes
-k or --keepOriginalIp	Do not override the network settings of the device with the ones in the backup file. It comes in handy when multiple devices' configuration is being restored from a single backup file. Default: false	optional

ATTENTION: The configuration is restored automatically if the factory default option is not applied in the **update** command. In that case, there is no need to run the **restore** command after the update.

Example

```
C:\Program Files (x86)\Lightware\Lightware Device Updater V2>LightwareDeviceUpdaterV2_CLI.cmd
restore --ip 192.168.1.12 --backupFile C:\mybackup.lw3 --keepOriginalIp

C:\Program Files (x86)\Lightware\Lightware Device Updater V2>lib\jre\bin\java.exe -jar lib\
ldu2.jar restore --ip 192.168.1.12 --backupFile C:\mybackup.lw3 --keepOriginalIp
[2021-05-12 10:49:36.412] [ INFO] [          main] - Executing configuration restore...
[2021-05-12 10:49:36.425] [ INFO] [          main] - Device IPs: [192.168.1.12]
```

INFO: The firmware package checks the backup data before the restore procedure and if it is necessary, a conversion is applied to avoid incompatibility problems between the firmware versions. In that case, two backup files are created: the original and a new one with "_converted" suffix. Using the last one for restoring is recommended.

9.6.7. Package Options

Shows package-specific update options.

Command

```
LightwareDeviceUpdaterV2_CLI.cmd packageOptions [options]
```

Options

Option	Description	Required?
-p or --package	The path of the firmware package file	yes

Example

```
C:\Program Files (x86)\Lightware\Lightware Device Updater V2>LightwareDeviceUpdaterV2_CLI.cmd
packageOptions --package c:\Firmwares\ubex_v2.1.0b3.lfp2

C:\Program Files (x86)\Lightware\Lightware Device Updater V2>lib\jre\bin\java.exe -jar lib\
ldu2.jar packageOptions --package c:\Firmwares\ubex_v2.1.0b3.lfp2

Backup and restore options:
  --skipPresetsAtRestore : if true, device presets will not be restored. (Default: false)
  --uploadDefaultMiniWeb : if true and no custom miniweb is present on the device, the
default built-in miniweb will be uploaded to the device. (Default: false)

Test options:
  --test : if true, no update will be performed, communication with the device will be
tested. (Default: false)
```

Package option example can be seen in the following section.

9.6.8. Complex Examples

The following options applied:

- Firmware is updated
- Factory default settings restored

```
C:\Program Files (x86)\Lightware\Lightware Device Updater V2>LightwareDeviceUpdaterV2_CLI.cmd
update --ip 192.168.1.12 --factoryDefault --package c:\Firmwares\ubex_v2.1.0b3.lfp2

C:\Program Files (x86)\Lightware\Lightware Device Updater V2>lib\jre\bin\java.exe -jar lib\ldu2.
jar update --ip 192.168.1.12 --factoryDefault --package c:\Firmwares\ubex_v2.1.0b3.lfp2
[2021-05-12 11:22:09.089] [ INFO] [      main] - Device IPs: [192.168.1.12]
[2021-05-12 11:22:12.947] [ INFO] [      main] - All the selected devices are accessible
over the network.
[2021-05-12 11:22:13.225] [ INFO] [      main] - All the selected devices are compatible
with the specified package.
[2021-05-12 11:22:13.777] [ INFO] [ 192.168.1.12] - Package version: 1.3.2b3
[2021-05-12 11:22:13.878] [ INFO] [ 192.168.1.12] - Login functionality is currently not
enabled.
[2021-05-12 11:22:13.896] [ INFO] [ 192.168.1.12] - Switching device into bootload mode...
[2021-05-12 11:22:34.519] [ INFO] [ 192.168.1.12] - Gathering UID information from device...
[2021-05-12 11:22:35.097] [ INFO] [ 192.168.1.12] - UID info - Device IP: 192.168.1.12
Product name: MX2-16x16-DH-8DPi-A-R Product part number: 91310068 Serial number: 00002263
```

```
Hardware version: V12 KAA0 MAC address: A8:D2:36:FF:22:63
[2021-05-12 11:22:35.589] [ INFO] [ 192.168.1.12] - Package version on device: 1.3.2b3 r44
[2021-05-12 11:22:35.626] [ INFO] [ 192.168.1.12] - Updating UBEX series application fw part
1...
[2021-05-12 11:22:36.123] [ INFO] [ 192.168.1.12] - [ubex.bin.ER_IROM1]'s current version
on device: 1.3.1b1 r35
[2021-05-12 11:22:36.124] [ INFO] [ 192.168.1.12] - [ubex.bin.ER_IROM1]'s version in the
package: 1.3.1b1 r35
[2021-05-12 11:22:52.439] [ INFO] [ 192.168.1.12] - [tps_tx200.bin.ER_IROM1]'s firmware
version updated in FVS EEPROM.
[2021-05-12 11:22:52.442] [ INFO] [ 192.168.1.12] - Updating VS100TX fw...
[2021-05-12 11:22:52.920] [ INFO] [ 192.168.1.12] - [vs100_tx.bin]'s current version on
device: 1.1.0b0 r0
[2021-05-12 11:22:52.921] [ INFO] [ 192.168.1.12] - [vs100_tx.bin]'s version in the package:
1.1.0b0 r63
[2021-05-12 11:23:06.423] [ INFO] [ 192.168.1.12] - [vs100_tx.bin]'s firmware version
updated in FVS EEPROM.
[2021-05-12 11:23:06.425] [ INFO] [ 192.168.1.12] - Updating UBEX series application fw part
2...
[2021-05-12 11:23:06.903] [ INFO] [ 192.168.1.12] - [mx2.bin.ER_IROM2]'s current version on
device: 1.3.1b1 r35
[2021-05-12 11:23:06.904] [ INFO] [ 192.168.1.12] - [mx2.bin.ER_IROM2]'s version in the
package: 1.7.0b17 r35
[2021-05-12 11:23:27.858] [ INFO] [ 192.168.1.12] - [mx2.bin.ER_IROM2]'s firmware version
updated in FVS EEPROM.
[2021-05-12 11:23:27.860] [ INFO] [ 192.168.1.12] - Updating PS171 FW...
[2021-05-12 11:23:28.338] [ INFO] [ 192.168.1.12] - [ubex_family_ps171.bin]'s current
version on device: 1.0.6b0 r0
[2021-05-12 11:23:28.340] [ INFO] [ 192.168.1.12] - [ubex_family_ps171.bin]'s version in
the package: 1.7.0b17 r522
[2021-05-12 11:23:44.810] [ INFO] [ 192.168.1.12] - [ubex_family_ps171.bin]'s firmware
version updated in FVS EEPROM.
[2021-05-12 11:23:51.412] [ INFO] [ 192.168.1.12] - Setting system information...
[2021-05-12 11:23:57.994] [ INFO] [ 192.168.1.12] - Starting application...
[2021-05-12 11:25:44.239] [ INFO] [ 192.168.1.12] - Done

All 1 update(s) finished successfully.
```

9.6.9. Exit Codes

There is a return value in all cases, when a command run is finished. Currently, three codes are defined:

Code	Displayed text	Description
0	N/A	The update performed successfully
1	Update error (ErrorCode:1)	The error happened during the update
2	CLI error (ErrorCode:2)	The error happened before starting the update

The error line contains further information about the error.

Querying the Exit Code under Windows®

```
c:\Program Files (x86)\Lightware\Lightware Device Updater V2\echo %errorlevel%
0
```

Querying the Exit Code under Linux

```
echo $?
0
```

If this value is queried after the update and it is 0, the update performed successfully.

9.7. If the Update is not successful

- Restart the process and try the update again.
- If the device cannot be switched to bootload (firmware update) mode, you can do that manually as written in the User manual of the device. Please note that backup and restore cannot be performed in this case.
- If the backup cannot be created for some reason, you will get a message to continue the process without backup or stop the update. A root cause can be that the desired device is already in bootload (firmware update) mode, thus the normal operation mode is suspended and backup cannot be made.
- If an update is not successful, the **Export log** button becomes red. If you press the button, you can download the log file as a ZIP package, which can be sent to Lightware Support if needed. The log files contain useful information about the circumstances to find the root cause. *#bootload*

10

Troubleshooting





Usually, if the system seems not to transmit the signal as expected, the best strategy for troubleshooting is to check signal integrity through the whole signal chain starting from source side and moving forward to receiver end.







- ▶ Use Cases 199
- ▶ How to Speed Up the Troubleshooting Process 201



























10.1. Use Cases























At first, check front panel LEDs and take the necessary steps according to their states. For more information about status LEDs, refer to the [Front and Rear View - F-series Endpoint Devices](#) section.





















Legend



















-  Link to connections/cabling section.
-  Link to device operation section.
-  Link to LDC software section.
-  Link to LW3 protocol commands section.
-  Link to Switchable USB protocol commands section.

Symptom	Root cause	Action	Refer to
Video signal			
No picture on the video output	Device or devices are not powered properly	Check the endpoints and the other devices if they are properly powered; try to unplug and reconnect them.	 4.4.3
	Cable connection problem	Cables must fit very well, check all the connectors (HDMI and optical/DAC cables).	 4.4  4.6
	Optical cable became contaminated	Use special fiber optical cable cleaning equipment to clean it carefully.	
	No incoming signal (RX/TRX)	If the front panel LINK OK LED does not light, no connection is established between the endpoints. Check the cable connections on the SFP+ ports.	 4.6
	Singlemode-multimode SFP+ module pairs	Check the installed SFP+ modules and install multimode or singlemode modules by pairs only.	 4.6
	SFP module is installed instead of SFP+ module	Install SFP+ transceiver module to the SFP+ port	 4.6
	Incorrect optical cabling of the SFP+ modules or Neutrik opticalCON connectors	Check the cabling of the modules or connectors	 4.7

Symptom	Root cause	Action	Refer to
	Different lengths of copper cables are applied for the SFP+ to RJ45 modules	Install equal lengths for both copper Ethernet cables	 4.4.1
	Not the proper video stream is the active one (RX)	Check which video stream is switched to the current output (the setting is available in the transmitter side).	 3.4.2  6.4  7.5.4
	Video stream is disabled (TX)	Enable the stream.	 3.4.1  6.5.4  7.5.6
	Video stream is disabled (RX)	Enable the stream.	 3.5.2  7.6.7
Video signal			
No picture on the video output	Video stream is disabled (TRX)	Enable the stream.	 3.6.2  6.5.4  7.7.5
	Sink device is not able to receive/display the video format	Check the emulated EDID; select another (e.g. emulate the EDID of the display on the input port).	 3.8  6.9.1  7.13
		Scale the stream on HDMI in 1 and 2 ports of the transmitter to the resolution and refresh rate of the sink device.	 3.4.1  6.5.3  7.5.9
		Scale the stream on the HDMI out 1 and 2 ports of the receiver to the resolution and refresh rate of the sink device.	 3.5.2  6.5.6  7.6.8
		Scale the stream on HDMI in 2 port of the transceiver to the resolution and refresh rate of the sink device.	 3.6.1  6.5.3  7.7.11
		Scale the stream on HDMI out 1 port of the transceiver to the resolution and refresh rate of the sink device.	 3.6.2  6.5.6  7.7.11

Symptom	Root cause	Action	Refer to
	HDCP is disabled	Enable HDCP on the input ports of the transmitter.	 3.4.1  6.5.1  7.5.16
Not the desired picture displayed on the video output	Video output is set to test pattern (no sync screen) statically (RX)	Check No sync screen settings in the HDMI output properties (RX).	 3.5.2  6.8.2  7.6.19
	Video output is set to test pattern (no sync screen) as there is no picture on video source	Check video settings of the source.	
Video signal			
Colors of the video is incorrect	Incorrect color space setting is active (TX)	Check the color space settings on the TX side	 3.4.1  6.5.3  6.5.4  7.5.12
	Incorrect color space setting is active (RX)	Check the color space settings on the RX side	 3.5.2  6.5.6  7.6.12
Source locked mode cannot be set	The resolution of the source stream and the sink device are not the same	Set the scaler to passthrough mode or set the forced resolution to the same as the source stream's one.	 3.5.2  3.6.2  6.5.3  6.5.6  7.5.9  7.6.8  7.7.8
Multiviewer			
The tile does not appear on the canvas	The tile is disabled.	Enable the tile.	 7.8.2
	The HDCP authentication failed, black screen appears in the tile.	Set the HDCP-level to the correct one or check the content on the source side.	 7.8.11
	There is no input stream for the tile.	Check video settings of the source.	 7.5.4

Symptom	Root cause	Action	Refer to
	The tile is beyond the canvas.	Check the position of the tile.	 7.8.3
	The resolution of the source stream and the tile size is not the same.	Check the resolution of the source stream. Check the size of the tile.	 3.4.1  6.5.4  7.5.8  7.8.4
	The color format of the input stream is YCbCr but multiviewer supports RGB only.	Check the color space setting of the source stream. UBEX multiviewer supports RGB color space only.	 3.4.1  6.5.4  7.5.12
Audio signal			
No audio is present on output	Source audio volume is low or muted	Check the audio settings of the source.	
	The incoming audio signal is unsupported	Query the status of the audio output port and select a supported signal source	 7.11.4
	The analog audio output port is muted	Check the analog audio output port properties	 6.7.2  7.10.5
	Volume of the analog audio port is set low	Check the analog audio input/output port properties	 6.7.1  6.7.2  7.10.1  7.10.2
HDMI output signal contains no audio	DVI EDID is emulated	Check the EDID and select and HDMI EDID to emulate (the setting is available in the transmitter side).	 3.8  6.9.1  7.13
Not the desired audio can be heard on the output	Audio stream is switched to another output	Check which audio stream is switched to the current output.	 6.6  7.9.4
LDC returns with "HBR audio not supported" error message	Currently installed LDC and endpoint firmware versions does not support HBR audio	Update LDC and endpoint firmwares to the latest released version	 6.1
Network			

Symptom	Root cause	Action	Refer to
No LAN connection can be established	Incorrect IP address is set (fix IP)	Use dynamic IP address by enabling DHCP option.	 3.11.1  6.11.2  7.14.2
		Restore the factory default settings (with DHCP).	 3.11.5  6.11.4  7.4.18
	IP address conflict	Check the IP address of the other devices, too.	
RS-232 signal			
Connected serial device does not respond	Cable connection problem	Check the connectors to fit well; check the wiring of the plugs.	 4.4.5  13.12.1
	RS-232 settings are different	Check the port settings of the endpoint and the connected serial device.	 6.10.2  7.15
	Messaging via serial port is not working	Check the serial messaging rules and/or apply escaping in the message.	 7.17
USB K+M (F120 and F121 models)			
Not all keyboard/mouse keys are working with K+M	Special function keys may not be supported in emulated mode	Usage of ordinary keyboards built up to 104/105 keys and ordinary mice is recommended.	 4.4.10
Host cannot be controlled by the keyboard and the mouse	The control mode is set to Local mode.	Set the wished control mode.	 6.10.4  7.18.1
USB KVM and USB 2.0 extension (F130 model)			
Host cannot be controlled by the keyboard and the mouse	The remote extender (REX) is not paired with the local extender (LEX).	Pair the devices.	 8.6.4
Miscellaneous			
Front panel button is out of operation	The button is locked	Disable control lock.	 6.11.3  7.4.15
I cannot find my device in the server room	All AV boxes and gadgets look the same	Use the "Identify Me" feature	 6.11.1  7.4.6

10.2. How to Speed Up the Troubleshooting Process

Lightware's technical support team is always working hard to provide the fastest support possible. Our team's response time is one of the best in the industry, and in the toughest of cases we can directly consult with the hardware or software engineer who designed the product, to get the information from the most reliable source.

However, the troubleshooting process can be even faster... with your help.

There are certain pieces of information that push us in the right direction to finding the root cause of the problem. If we receive most of this information in the first e-mail, or it is gathered at the time when you call us, then there is a pretty high chance that we will be able to respond with the final solution right away.

This information is the following:

- Schematic (a pdf version is preferred, but a hand drawing is sufficient).
- Serial number(s) of the device(s) (it is either printed somewhere on the box or you can query it in the Device Controller software or on the built-in website).
- Firmware versions of the devices (please note that there may be multiple CPUs or controllers in the device and we need to know all of their firmware versions, a screenshot is the best option).
- Cable lengths and types.
- Patch panels, gender changers or anything else in the signal path that can affect the transmission.
- Signal type (resolution, refresh rate, color space, deep color).
- Emulated EDID(s) (please save them as a file and send it to us).
- Actions to take in order to re-create the problem (if we cannot reproduce the problem, it is hard for us to find the cause).
- Photo or video about the problem (for example: "image noise" can mean many different things, it's better if we see it too).
- Error logs from the Device Controller software.
- In the case of Event Manager issue, the event file and/or backup file from the Device Controller software.

The more of the above information you can give us, the better. Please send this information to the Lightware Support Team (support@lightware.com) to speed up the troubleshooting process.

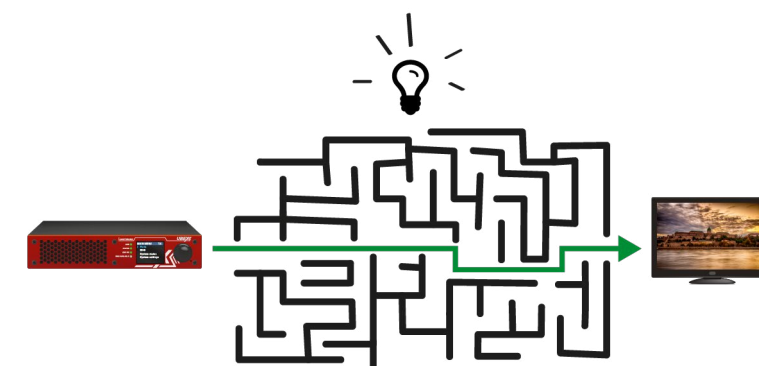

11

Technologies

The following sections contain descriptions and useful technical information on how the devices work in the background. The content is based on experiences and cases we met in practice. These sections help to understand features and technical standards like the following:

- ▶ EDID Management 203
- ▶ HDCP Management 204
- ▶ Pixel Accurate Reclocking 206
- ▶ AV Over IP 207

11.1. EDID Management

11.1.1. Understanding the EDID

The Extended Display Identification Data (EDID) is the passport of display devices (monitors, TV sets, projectors). It contains information about the capabilities of the display, such as supported resolutions, refresh rates (these are called Detailed Timings), the type and manufacturer of the display device, etc.

After connecting a source to a display (DVI, HDMI, DP), the source reads out the EDID to determine the resolution and refresh rate of the image to be transmitted.

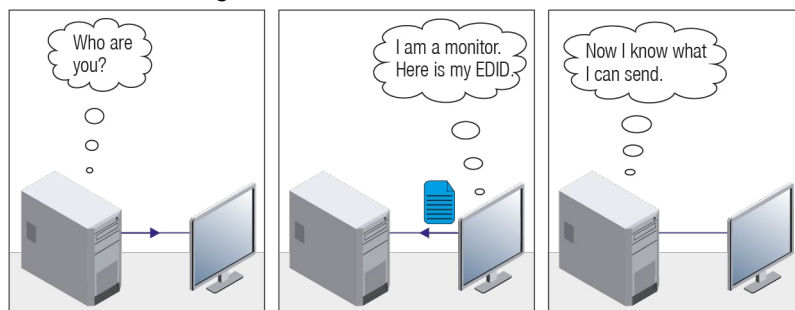

EDID communication

Most DVI computer displays have a 128-byte-long EDID structure. However, Digital Televisions and HDMI capable displays may have another 128 bytes, which is called E-EDID and defined by CEA (Consumer Electronics Association). This extension contains information about additional Detailed Timings, audio capabilities, speaker allocation and HDMI capabilities. It is important to know that all HDMI capable devices must have CEA extension, but not all devices with CEA extension are HDMI capable.

Common Problems Related to EDID

Problem: “My system consists of the following: a computer, a Lightware device, a WUXGA (1920x1200) LCD monitor, and an SXGA (1280x1024) projector. I would like to see the same image on the monitor and the projector. What EDID should I choose on the Lightware device?”

Solution: If you want to see the image on both displays, you need to select the resolution of the smaller display (in this case SXGA), otherwise the smaller display may not show the higher resolution image.

Problem: “I have changed to a different EDID on an input port of the Lightware device to have a different resolution, but nothing happens.”

Solution: Some graphics cards and video sources read out the EDID only after power-up, and later they do not sense that the EDID has been changed. You need to restart your source to make it read out the EDID again.

11.1.2. Advanced EDID Management

Each DVI sink (e.g. monitors, projectors, plasma displays, etc...) must support the EDID data structure. Source BIOS and operating systems are likely to query the sink using DDC2B protocol to determine what pixel formats and interface are supported. DVI standard uses EDID data structure to identify the monitor type and capabilities. Most DVI sources (VGA cards, set top boxes, etc.) will output DVI signal after accepting the connected sink's EDID information. In the case of EDID readout failure or missing EDID, the source will not output DVI video signal.

Lightware devices provide the Advanced EDID Management function that helps system integration. The built-in EDID Router can store and emulate factory pre-programmed- and User programmable EDIDs. The EDID of the attached monitors or projectors for each output are stored in a non-volatile memory. This way, the EDID of a monitor is available when the monitor is unplugged or switched off.

Any EDID can be emulated on any input. An emulated EDID can be copied from the EDID router's memory (static EDID emulation), or from the last attached monitor's memory (dynamic EDID emulation). For example, the Lightware device can be set up to emulate a sink device, which is connected to one of the outputs. In this case, the EDID automatically changes if the monitor is replaced with another display device (as long as it has a valid EDID).

The EDID is independently programmable for all inputs without affecting each other. All inputs have their own EDID circuit.

INFO: The user is not required to disconnect the video cable to change an EDID as opposed to other manufacturer's products. The EDID can be changed even if a source is connected to the input and powered ON.

INFO: When the EDID has been changed, the router toggles the HOTPLUG signal for 2 seconds. Some sources do not sense this signal. In such cases, the source device must be restarted or powered OFF and ON again.

11.2. HDCP Management

Lightware Visual Engineering is a legal HDCP adopter. Several functions have been developed that help to solve HDCP related problems. Complex AV systems often have both HDCP and non-HDCP components. The matrix allows transmitting HDCP encrypted and unencrypted signals. The devices will be still HDCP compliant as they will never output an encrypted signal to a non-HDCP compliant display device. If an encrypted signal is switched to a non-compliant output, a red screen alert or muted screen will appear.

11.2.1. Protected and Unprotected Content

Many video sources send HDCP protected signal if they detect that the sink is HDCP capable – even if the content is not copyrighted. This can cause trouble if an HDCP capable device is connected between the source and the display. In this case, the content cannot be viewed on non-HDCP capable displays and interfaces like event controllers. Rental and staging technicians often complain about certain laptops, which are always sending HDCP encrypted signals if the receiver device (display, matrix router, etc.) reports HDCP compliancy. Even though, HDCP encryption is not required all the time (e.g. computer desktop image), certain laptops still do that.

To avoid unnecessary HDCP encryption, Lightware introduced the HDCP enabling/disabling function: the HDCP capability can be disabled in the Lightware device. If HDCP is disabled, the connected source will detect that the sink is not HDCP capable, and turn off authentication.

11.2.2. Disable Unnecessary Encryption

HDCP Compliant Sink

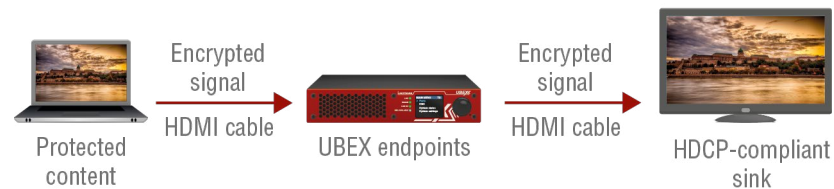

All the devices are HDCP-compliant, no manual setting is required, both protected and unprotected contents are transmitted and displayed on the sink.

Not HDCP-compliant Sink 1.



Non-HDCP compliant sink is connected to the endpoints. Some sources (e.g. computers) always send HDCP encrypted signals if the receiver device reports HDCP compliancy, however, HDCP encryption is not required all the time (e.g. computer desktop image). If HDCP is enabled in the endpoint, the image will not be displayed on the sink.

Setting the HDCP parameter to Auto on the output port and disable HDCP on the input port, the transmitted signal will not be encrypted if the content is not protected. Thus, non-HDCP compliant sinks will display non-encrypted signal.

Not HDCP-compliant Sink 2.

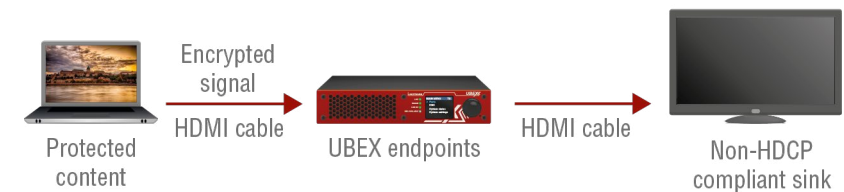

The layout is the same as in the previous case: non-HDCP compliant display device is connected to the endpoints but the source would send protected content with encryption. If HDCP is enabled on the input port of the endpoint, the source will send encrypted signal. The sink is not HDCP compliant, thus, it will not display the video signal (but blank/red/muted/etc. screen). If HDCP is disabled on the input port of the transmitter, the source will not send the signal. The solution is to replace the display device to an HDCP-capable one.

11.2.3. HDCP v2.2

HDCP v2.2 is the latest evolution of copy protection. It is designed to create a secure connection between a source and a display. The 2.x version of HDCP is not a continuation of HDCPv1, and is rather a completely different link protection. One of the main differences is the number of the allowed devices within a closed A/V system: HDCP v2.2 allows 32 devices (HDCP v1.4 allows 128 devices). A further limit is that up to four level is allowed, which means the protected signal can be transmitted over at most four repeater/matrix/switcher device. HDCP content protection is activated only if an active video stream is transmitted from the source to the display. The encryption is not activated without a video signal.

HDCP v2.2 standard allows the application of a previous version of HDCP (e.g. HDCP v1.4) between the source and the display if the source device allows it. According to the standard, if the image content is protected with HDCP, the highest supported content protection level has to be applied. However, if the highest level of protection is not justified by the source content, the level may be decreased to avoid compatibility problems; this case is determined by the source.

HDCP v2.2 Source and HDCP v1.4 Sink

In this case the signal of an HDCP v2.2 compliant source is switched to an HDCP v1.4 compliant sink device. The signal is encrypted with HDCP v2.2 on the input and encrypted with HDCP v1.4 on the output of the Lightware device. A lower level of encryption may be applied only if the source device/content allows it - according to the HDCP standard. In this case the HDCP setting on the input port has to be set to HDCP 1.4 and depends on input on the output port.

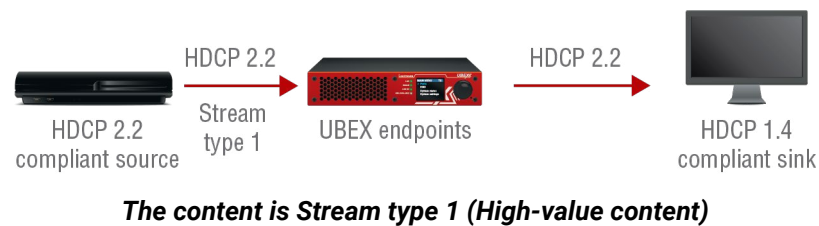
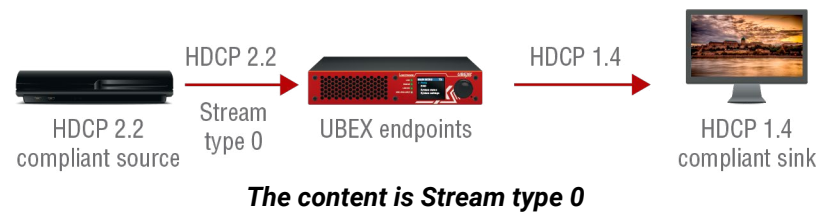

HDCP v1.4 Source and HDCP v2.2 Sink

The example below is the reversal of the previous case. An HDCP v1.4 compliant source sends a signal with HDCP v1.4 encryption. The signal is switched to an HDCP v2.2 compliant sink device. In this case the outgoing signal has to be encrypted with the highest supported encryption level towards the sink, as the Lightware device and the sink are both HDCP v2.2 compliant. The HDCP v2.2 standard does not allow keeping the original HDCP v1.4 encryption level on the output.



What Kind of Signal Will be on the Output of the Lightware Device?

See below table that summarizes the possible cases:

Incoming Signal	HDCP v1.4 Compatible Sink on the Output	HDCP v2.2. Compatible Sink on the Output
HDCP v1.4	HDCP v1.4	HDCP v2.2
HDCP v2.2 (convertible)*	HDCP v1.4	HDCP v2.2
HDCP v2.2 (not convertible)*	Black screen	HDCP v2.2

* Stream type 0: the video stream allows the conversion of the signal to apply a lower level of encryption.

** Stream type 1 (High-value content): the video stream does not allow the conversion of the signal.

11.3. Pixel Accurate Reclocking

Signal reclocking is an essential procedure in digital signal transmission. After passing the reclocking circuit, the signal becomes stable, jitter-free, and can be transmitted over more equipment like processors, or event controllers. Without reclocking, sparkles, noise, and jaggies appear on the image.

Lightware’s sophisticated Pixel Accurate Reclocking technology fixes more problems than general TMDS reclocking. It removes not only intra-pair skew, but inter-pair skew as well. The Pixel Accurate Reclocking circuit eliminates the following errors:

Intra-pair skew

Skew between the + and - wires within a differential wire pair (e.g. Data2- and Data2+). It’s caused by different wire lengths or slightly different wire construction (impedance mismatch) in the DVI cable. It results in jitter.

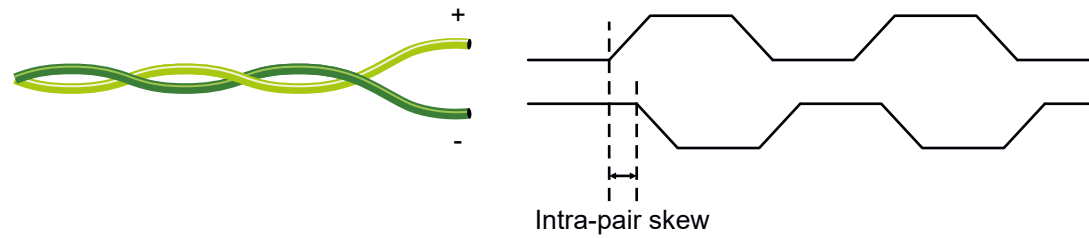

Inter-pair skew

Skew between two differential wire pairs in a cable. It is caused by different wire pair lengths or different number of twists in the DVI cable. Too much inter-pair skew results in color shift in the picture or sync loss.

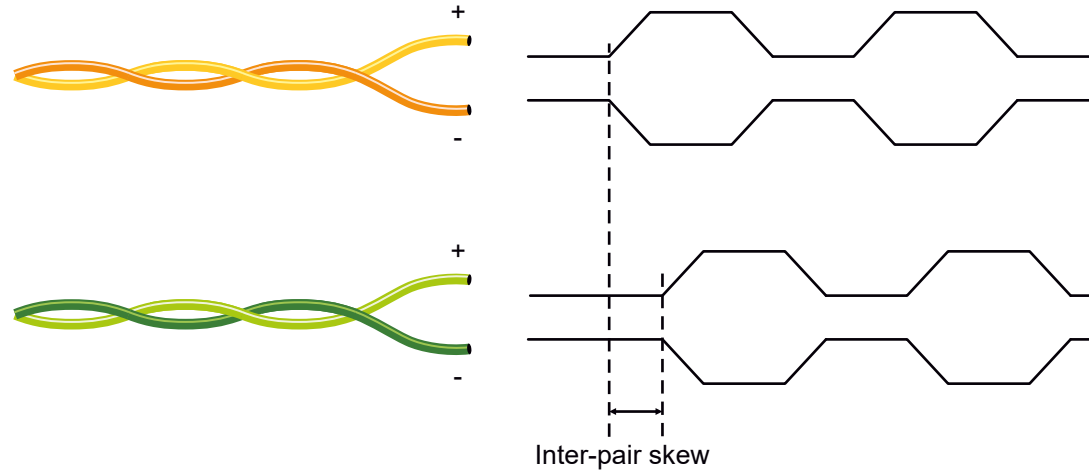

Jitter

Signal instability in the time domain. The time difference between two signal transitions should be a fixed value, but noise and other effects cause variations.

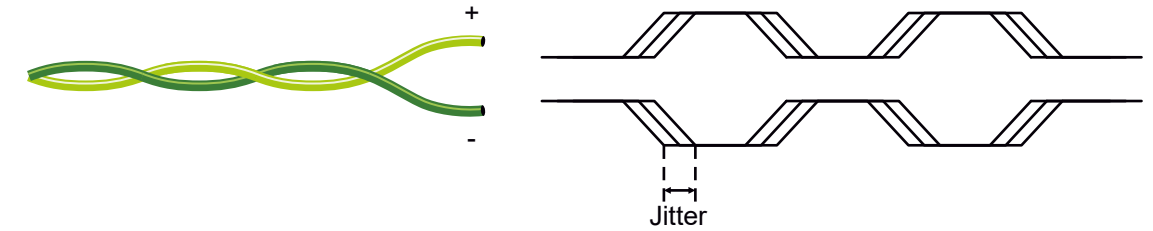

Noise

Electromagnetic interference between other electronic devices such as mobile phones, motors, etc. and the DVI cable are coupled onto the signal. Too much noise results in increased jitter.

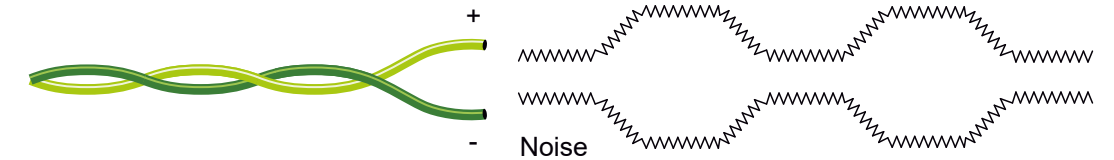

INFO: The colors of the wire pairs in the pictures are for illustration and do not represent the color of the actual wires inside the cable.

11.4. AV Over IP

11.4.1. Basics

Besides the traditional AV matrix switchers and extenders, the AV over IP or networked AV system is the biggest leading technology in the AV industry. The spreading of the technology speeds up the general increase of the usage of the IT-related devices and equipment all around the world - from the offices to the homes.

The main difference compared to the traditional AV technologies is the method of the signal transmission: the networked AV transmitter/encoder devices convert the video signal to TCP/IP packets and transfer them to the receivers/decoders. The interface of the transmission can be CATx or fiber optical cable depending on the signal bandwidth and the distance between the source and sink devices.

11.4.2. What is TCP/IP?

DEFINITION: TCP/IP, or the Transmission Control Protocol/Internet Protocol, is a suite of communication protocols used to interconnect network devices on the Internet or in a private network.

TCP/IP specifies how data is exchanged over the network by providing end-to-end communications that identify how it should be broken into packets, addressed, transmitted, routed and received at the destination. TCP/IP requires little central management, and it is designed to make networks reliable, with the ability to recover automatically from the failure of any device on the network. *

The two main protocols in the Internet protocol suite serve specific functions. TCP defines how applications can create channels of communication across a network. It also manages how a message is assembled into smaller packets before they are then transmitted over the Internet and reassembled in the right order at the destination address. *

IP defines how to address and route each packet to make sure it reaches the right destination. Each gateway computer on the network checks this IP address to determine where to forward the message. *

* Source: <https://searchnetworking.techtarget.com/definition/TCP-IP>

11.4.3. Link Aggregation Protocol

The UBEX endpoints use Link Aggregation Control Protocol (LACP) to share the signal bandwidth of the streams equally between the two the SFP+ ports.

DEFINITION: The **Link Aggregation Group** (LAG) applies to various methods of combining (aggregating) multiple network connections in parallel in order to increase throughput beyond what a single connection could sustain.

The measurement of the bandwidth can happen via/using two different methods on the two interfaces:

- HDMI pipes: the peak bandwidth is measured, which is the summary of the video burst (horizontal (H) blanking and vertical (V) blanking).
- SFP+ links: the average bandwidth is measured.

Example for the Link Aggregation Protocol

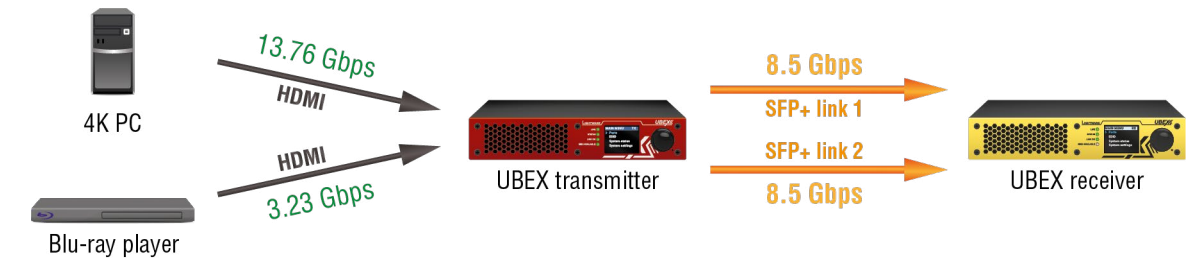

Example for the working of the LACP

11.4.4. Multicast DNS (mDNS) Protocol

The multicast DNS (mDNS - (multicast Domain Name System) protocol resolves host names to IP addresses within small networks that do not include a local name server. It is a zero-configuration service, using essentially the same programming interfaces, packet formats and operating semantics as the unicast Domain Name System (DNS). *

The primary benefits of using mDNS is that it requires little or no administration to set up. Unless the network is specifically configured to not allow mDNS, UBEX sources will be discovered. This format works when no infrastructure is present, and can span infrastructure failures.

* Source: https://en.wikipedia.org/wiki/Multicast_DNS

12

Assembly Guides

This chapter contains step-by-step assembly guides for the UBEX series devices like the following:

- ▶ Front Plate Exchange for F-series Endpoint Devices 209
- ▶ SFP+ Module Changing in R-series Endpoints 212
- ▶ Air Filter Foam Changing in R-series Endpoints 213
- ▶ Hidden USB Connector for Debug Purpose 214

12.1. Front Plate Exchange for F-series Endpoint Devices

The section is about the assembling of the UBEX F-series endpoint devices that contains detailed step-by-step guides and the tool requirements.

Affected Models

The front plate can be changed on the following endpoint models:

- UBEX-PRO20-HDMI-F100
- UBEX-PRO20-HDMI-F110
- UBEX-PRO20-HDMI-F111
- UBEX-PRO20-HDMI-F120
- UBEX-PRO20-HDMI-F121
- UBEX-PRO20-HDMI-F130

12.1.1. Tool Requirements



Plastic spudger tool



1.3 mm hex wrench (Allen) key



PZ1 screwdriver

12.1.2. The Steps of the Front Plate Exchange

Removal of the Front Plate

Step 1. Remove the **rubber ring** carefully from the jog dial knob using the plastic spudger tool.

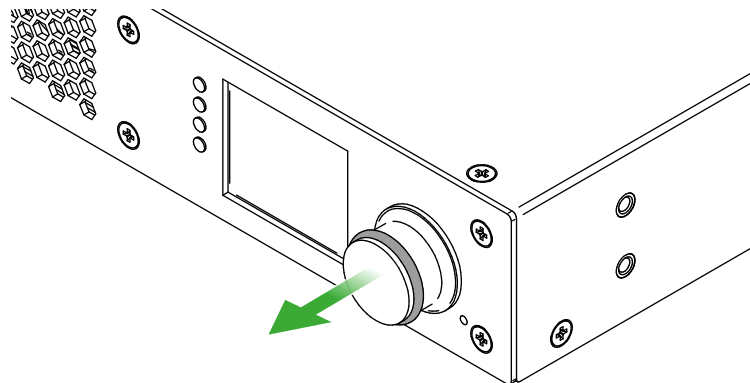

Step 2. Find the screw in the side of the jog dial knob and use a **1.3 mm hexagon (Allen) wrench key** to loosen it.

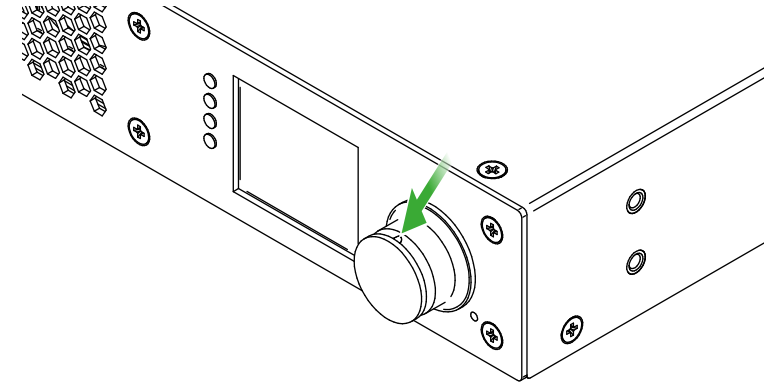

Step 3. Pull down the jog dial knob from the holder.

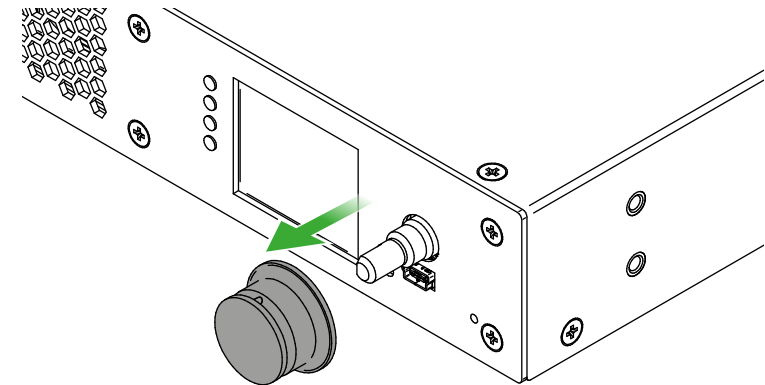

Step 4. Remove all **six screws** from the front plate using the PZ1 screwdriver.

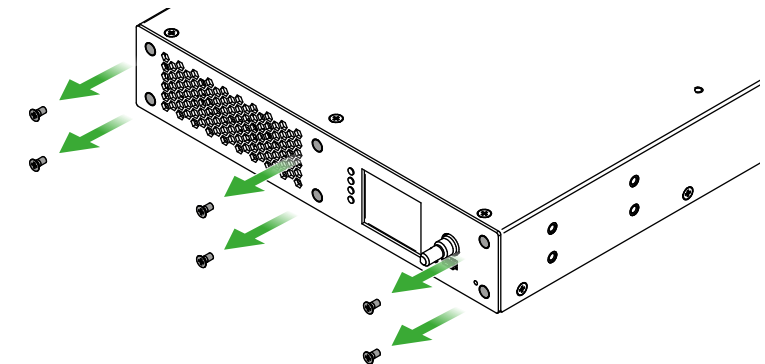

Step 5. Remove the front plate from the chassis.

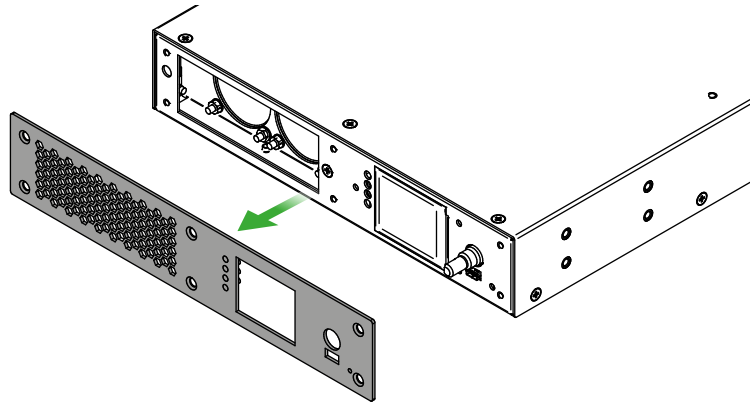

Step 6. Push out the **four light pipes** from the front plate **starting from the rear side** of the plate.

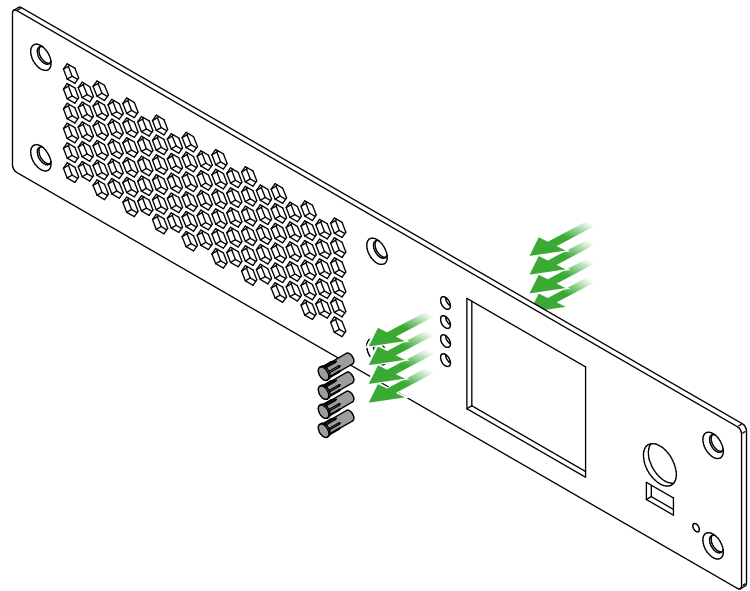

Insertion of the New Front Plate

Step 1. Insert the **four light pipes** to the new front plate **starting from the front side** of the plate. Take care of the direction of the light pipes.

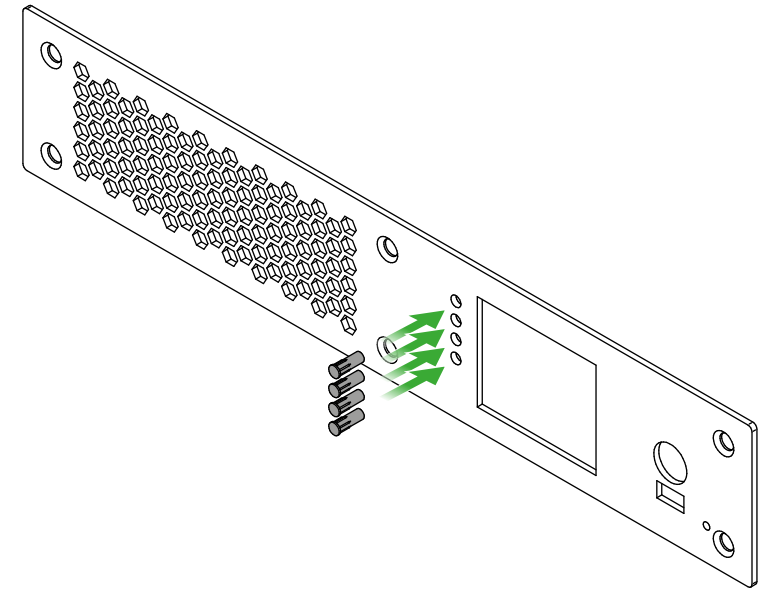

Step 2. Place the front plate on the chassis.

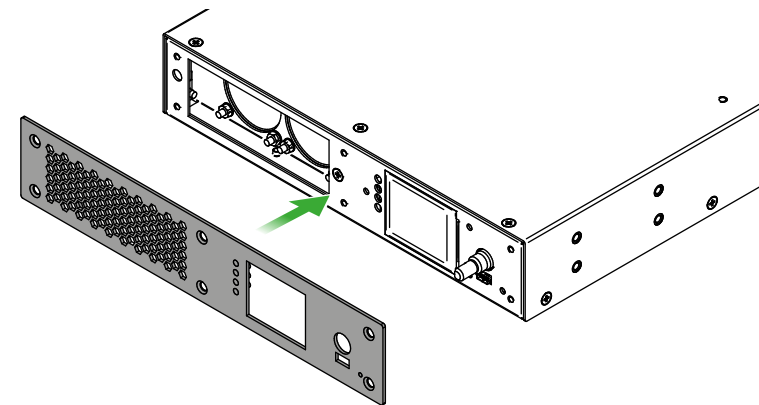

Step 3. Fasten all **six screws** on the front plate using the PZ1 screwdriver.

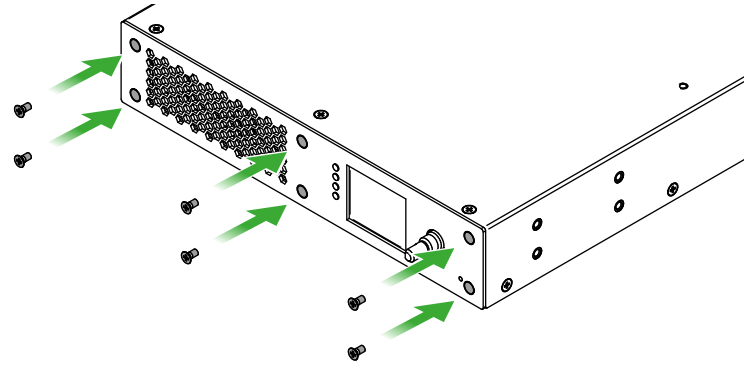

Step 4. Insert the **jog dial knob** to the holder so that the **fixing screw hole** shall be over the **flat part** of the holder.

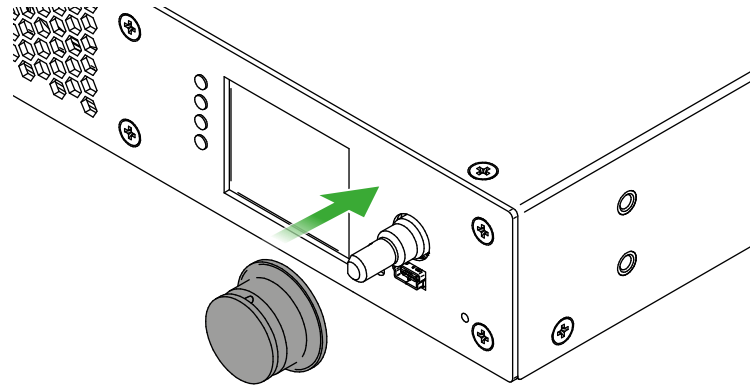

Step 5. Find the screw in the side of the jog dial knob and use a **1.3 mm hexagon (Allen) wrench key** to fasten it.

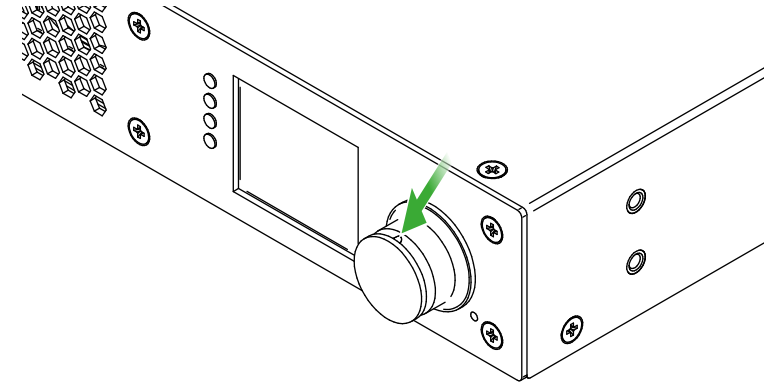

Step 6. Place the **rubber ring** carefully on the jog dial knob.

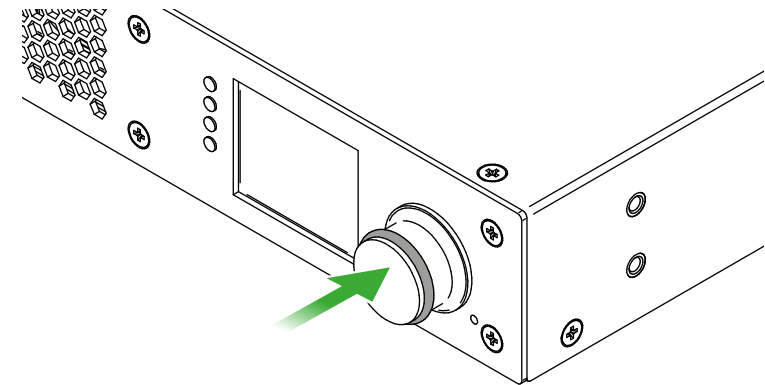

12.2. SFP+ Module Changing in R-series Endpoints

The R-series endpoint devices are built with pre-installed SFP+ modules inside the enclosure. The modules can be changed by the user in a few simple steps.

WARNING! Lightware highly recommends that the following operations to be done in ESD (Electrostatic Discharge) protected environment.

Affected Models

- UBEX-PRO20-HDMI-R100 series

SFP+ Modules inside the Enclosure

	Type of the SFP+ module	Number of modules	Optical Mode	Wavelength
2xMM-2xDUO	Finisar FTLX8574D3BCL	2	Multimode	850 nm
2xMM-QUAD	Finisar FTLX8574D3BCL	2	Multimode	850 nm
2xSM-2xDUO	Finisar FTLX1475D3BCL	2	Singlemode	1310 nm
2xSM-QUAD	Finisar FTLX1475D3BCL	2	Singlemode	1310 nm
2xSM-BiDi-DUO	Module A: Finisar FTLX2072D327	1	Singlemode	in: 1331 nm out: 1271 nm
	Module B: Finisar FTLX2072D333	1		in: 1271 nm out: 1331 nm

Removal of the Original SFP+ Modules

Step 1. Disconnect the device from the power source.

WARNING! Never disassemble the device when it is connected to the power source. The unit is built with open frame power supply module, touching it when the device is under power is dangerous.

Step 2. Remove five screws with a PZ1 screwdriver from the left side of the device (highlighted below with green).



R-series endpoint device - left view

Step 3. Remove five screws from the right side of the device (highlighted below with green).

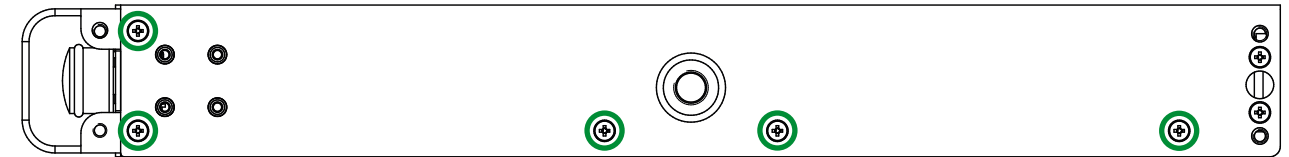

R-series endpoint device - right view

Step 4. Remove all five screws from the top cover of the device (highlighted below with green).

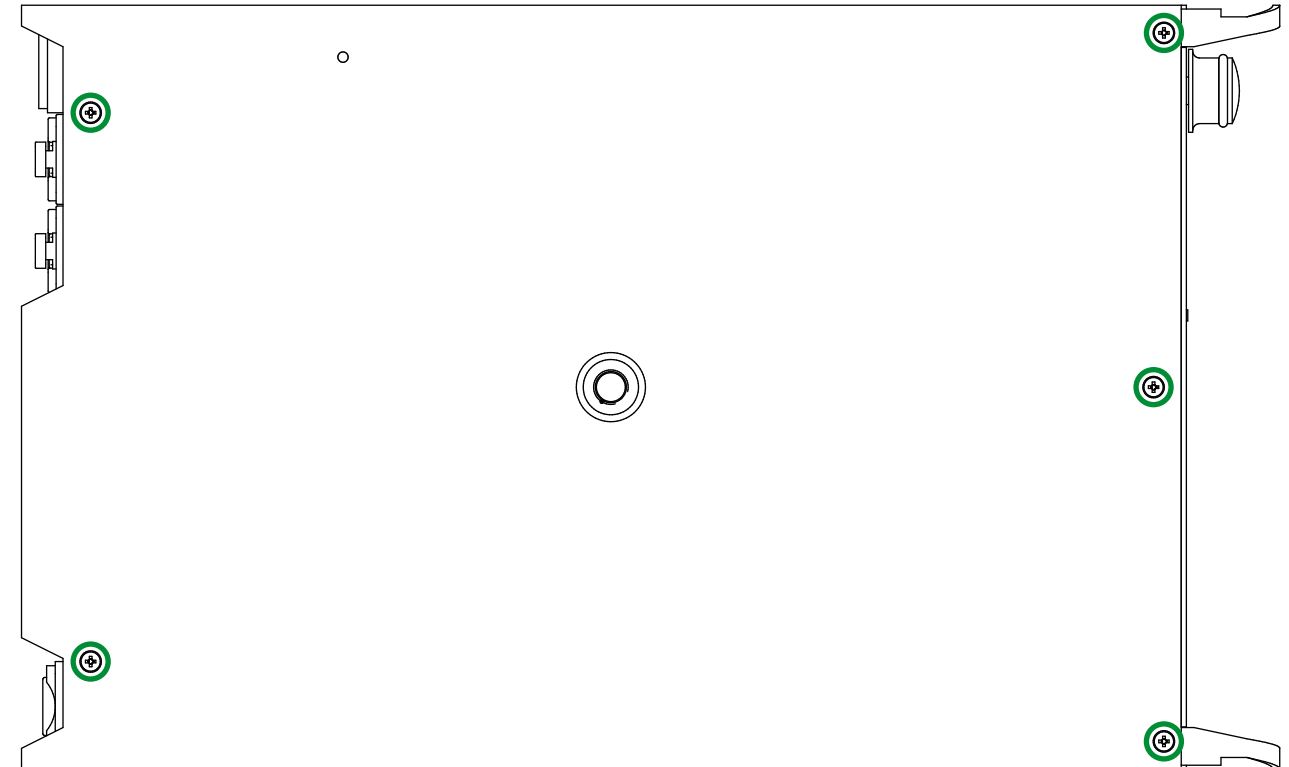

R-series endpoint device - top view

Step 5. Remove the top cover cautiously. Push the cover backwards a little, then remove it upwards.

ATTENTION: The protective ground cable is connected to the top cover. Be sure that the connection is not harmed when removing the cover.

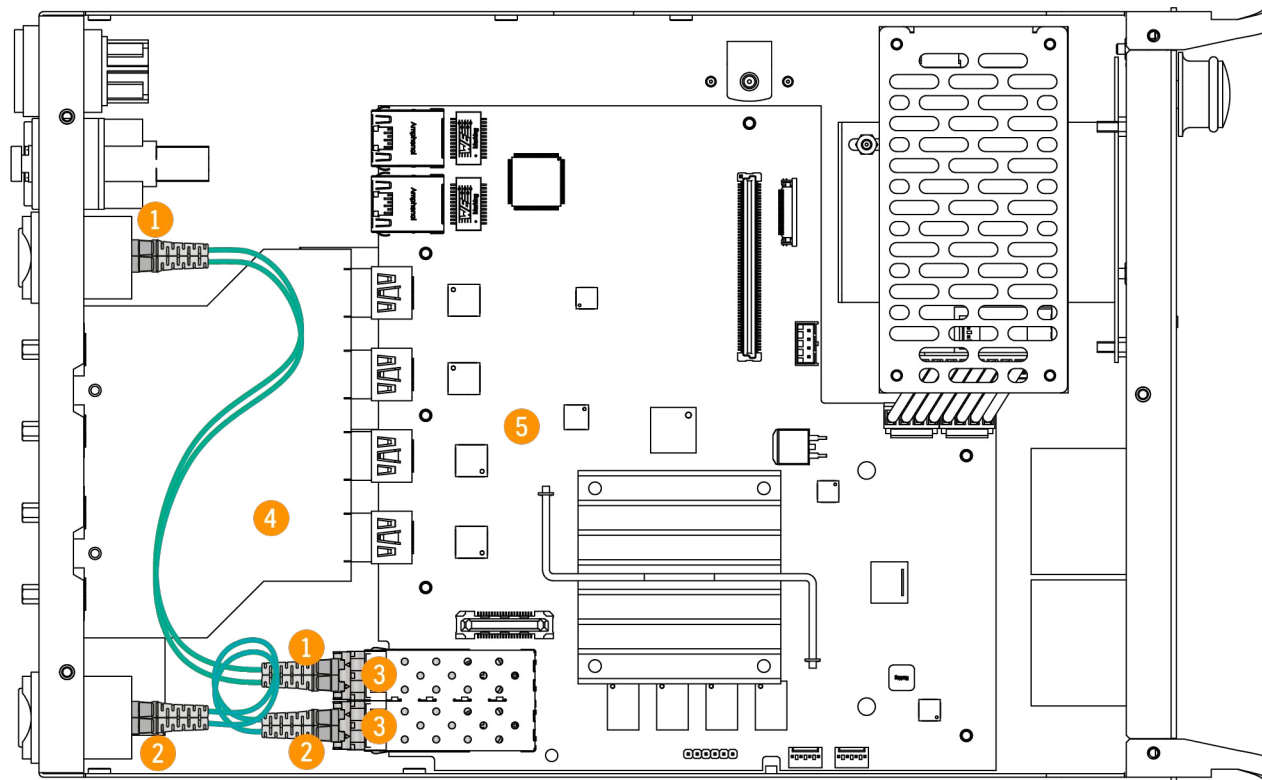

R-series endpoint device - top view in disassembled state

Step 6. Disconnect the LC patch cable connectors ① ② from the SFP+ modules ③.

Step 7. Pull down on the handle bar of the modules ③.

Step 8. Gently slide out the SFP+ modules ③ from the slot.

Installation of the New SFP+ Modules

ATTENTION: Always be sure of the optical mode of the new modules. 2xMM-2xDUO / 2xMM-QUAD models support **multimode**, 2xSM-2xDUO / 2xSM-QUAD / 2xSM-BiDi-DUO support **singlemode** SFP+ modules only.

Step 1. Put up on the handle bar of the new modules ③.

Step 2. Connect the modules ③ to the SFP+ port slots.

Step 3. Connect the LC patch cable connectors ① ② to the SFP+ modules.

ATTENTION: Always be sure of the optical mode of the patch cables. Multimode SFP+ modules support **multimode**, singlemode SFP+ modules support **singlemode** optical cables only.

Step 4. Place back the top cover cautiously.

Step 5. Screw back all 15 screws to the top, left, and right side of the cover plate of the device.

WARNING! Be careful when removing and installing the patch cables and the SFP+ modules. Harming the HDMI board ④ and the motherboard ⑤ may cause unusable device and will void the warranty.

12.3. Air Filter Foam Changing in R-series Endpoints

The R-series endpoint devices are built with an exchangeable air filter foam in front of the fans that can be easily removed for cleaning or changing.

Affected Models

- UBEX-PRO20-HDMI-R100 series

Removal of the Air Filter

Step 1. Disconnect the device from the power source.

WARNING! Never remove the air filter when it is connected to the power source. The cooling fans behind the foam are in operation when the device is on, touching the spinning parts may cause injury.

Step 2. Remove the air filter foam by fingers or using a forceps or clamp.

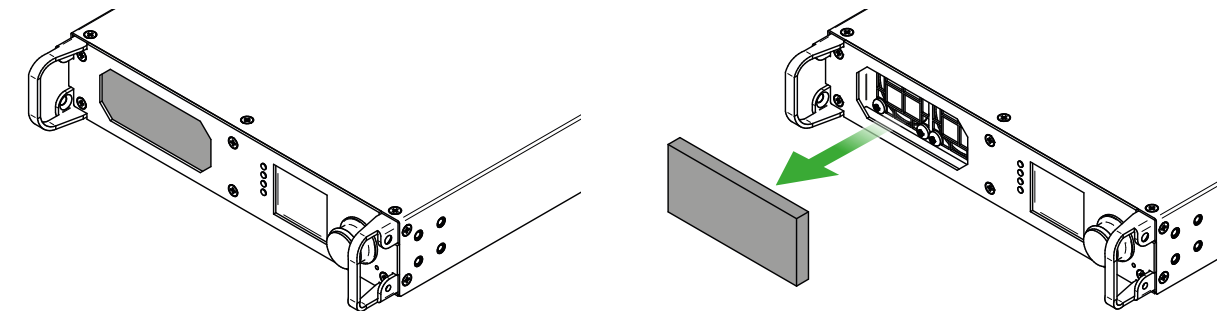

Parameters of the Foam

Size (in mm): 86W x 40H x 8D

Material: 25ppi polyurethane air filter foam

Installation of the Air Filter

Place the **cleaned** or **new air filter foam** in front of the cooling fans. Take care that **all corners** of the foam are **inside** the air filter slot.

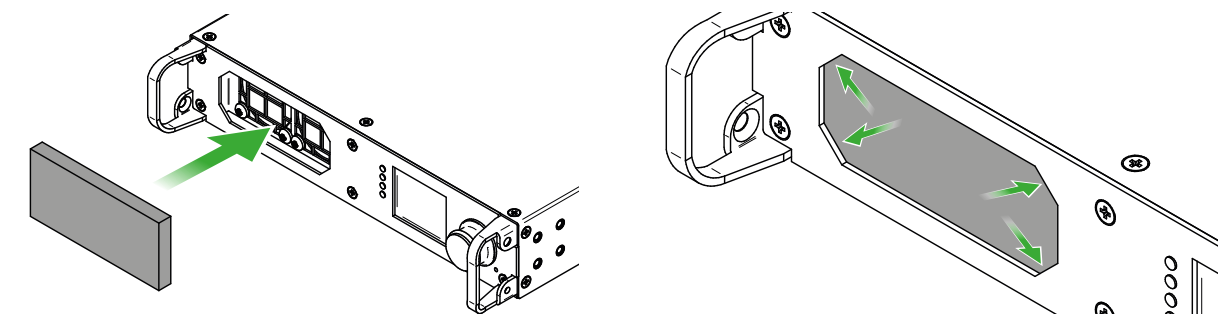

12.4. Hidden USB Connector for Debug Purpose

Affected Models

- UBEX-PRO20-HDMI-F100, -F110, -F111, -F120, -F121, -F130
- UBEX-PRO20-HDMI-R100 series

UBEX endpoints are built with a standard USB 2.0 mini B-type connector which is hidden under the jog dial control knob.

ATTENTION: The USB connector is for debug purpose. Please use it only if the Lightware Support requests it.

Follow the steps to reach the hidden USB connector:

Step 1. Remove the rubber ring from the jog dial knob.

Step 2. Find the screw in the side of the jog dial knob and use a **hexagon (Allen) key wrench size 1.3 mm** to loosen it.

Step 3. Pull down the jog dial knob from the holder.

Step 4. The USB mini connector is available now.

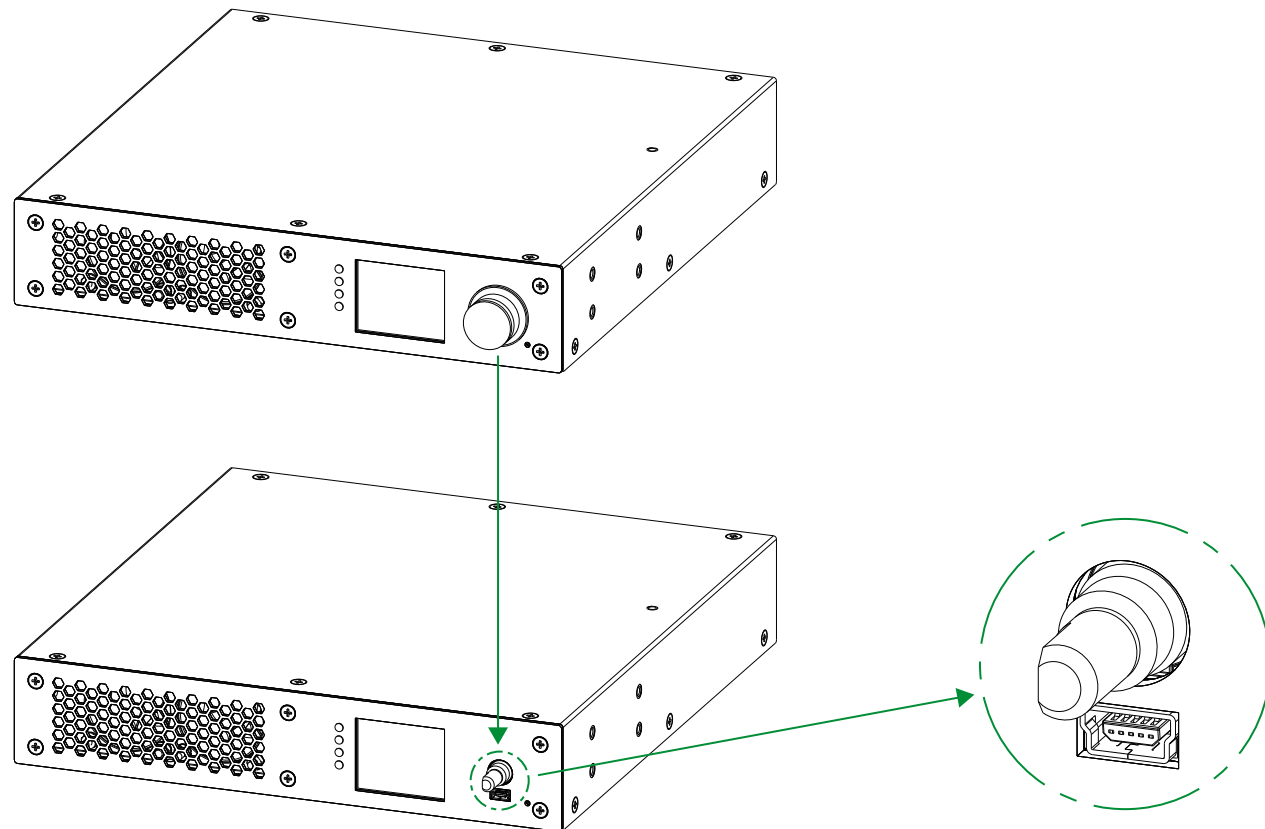

The location of the hidden USB mini connector

13

Appendix

Tables, drawings, guides, technical details, hashtag keyword list and the Quick Link Collection as follows:

▶ Specification	216
▶ Applied Ports (Network Settings)	221
▶ Maximum Cable Extensions	221
▶ Input/Output Port Numbering	222
▶ Factory Default Settings	227
▶ Content of Backup File	231
▶ Release Notes of the Firmware Packages	239
▶ Resolutions of the Scaler	244
▶ Factory EDID List	245
▶ Mechanical Drawings	246
▶ Bandwidth Requirements of the Resolutions	248
▶ Cable Wiring Guide	251
▶ Quick Link Collection	252
▶ Hashtag Keyword List	255
▶ Further Document Information	257
▶ Limited Warranty Statement	257

13.1. Specification

INFO: Specifications are subject to change without notice.

13.1.1. UBEX F-series Endpoints

General

Compliance	CE, UKCA
EMC (emission)	EN 55032:2015+A1:2020
EMC (immunity)	EN 55035:2017+A11:2020
RoHS	EN 63000:2018
Electrical safety	EN 62368-1:2020
Laser safety	EN 60825-1:2014+A11:2021
TEMPEST SDIP-27 Level B certification	Available upon request
Warranty	3 years
Cooling	2x built-in fans
Operating temperature	0 to +50°C (+32 to +122°F)
Storage temperature	-40° to +85°C (-40° to +185°F)
Operating humidity	10% to 90%, non-condensing

Power Supply

AC power connector	IEC C14 receptacle
Power source	100-230 V AC, 50/60 Hz

Power Consumption / Heat Dissipation *

Transmitted AV signals	Transmitter (TX) operation mode	Receiver (RX) operation mode	Transceiver (TRX) operation mode	Multiviewer (RXMV) operation mode
4K60	21.1 W	21.4 W	-	23.5 W
	72 BTU/h	73 BTU/h	-	80.2 BTU/h
4K30	20.3 W	20.2 W	-	-
	69.3 BTU/h	68.9 BTU/h	-	-
4K30 + 4K30	22.9 W	20.9 W	21.9 W	-
	78.1 BTU/h	71.3 BTU/h	74.7 BTU/h	-
4K60 + 1080p60	24.2 W	21.4 W	22.8 W	-
	82.6 BTU/h	73 BTU/h	77.8 BTU/h	-
4K60 + 4K30	22.1 W	21.1 W	21.6 W	-
	75.4 BTU/h	72 BTU/h	73.7 BTU/h	-

* Usage of SFP+ to RJ45 modules might increase these values with 3 W / 10.2 BTU/h approximately.

Enclosure

Rack mountable	Yes, with 1U high rack shelf
Material	1 mm steel
Dimensions (mm/inch)	221W x 230D x 42.5H / 8.7W x 9D x 1.6 H
Weight	2077 g (4,57 lbs)

Video Inputs

HDMI Input

Connector type	19-pole HDMI Type A receptacle
Number of ports	2
Standard	DVI 1.0, HDMI 2.0
Supported resolutions at 10 bits/color *	up to 4096x2160@60Hz (4:4:4) or 4096x2160@60Hz (4:2:2) up to 3840x2160@60Hz (4:4:4) or 3840x2160@60Hz (4:2:2)
Supported resolutions at 12 bits/color *	up to 4096x2160@60Hz (4:2:0) or 3840x2160@60Hz (4:2:0) up to 4096x2160@30Hz (4:2:2) or 3840x2160@30Hz (4:2:2) 1920x1080@60Hz (4:4:4)
Audio formats	8 channel PCM Dolby Digital, Dolby Digital Plus, Dolby TrueHD, Dolby Atmos DTS, DTS-HD Master Audio 7.1, WMA Pro

* All standard VESA, CEA and other custom resolutions up to 600MHz (HDMI 2.0) are supported.

Video Outputs**HDMI Output**

Connector type	19-pole HDMI Type A receptacle
Number of ports	2
Standard	DVI 1.0, HDMI 2.0
Supported resolutions at 10 bits/color *	up to 4096x2160@60Hz (4:4:4) or 4096x2160@60Hz (4:2:2) up to 3840x2160@60Hz (4:4:4) or 3840x2160@60Hz (4:2:2)
Supported resolutions at 12 bits/color *	up to 4096x2160@60Hz (4:2:0) or 3840x2160@60Hz (4:2:0) up to 4096x2160@30Hz (4:2:2) or 3840x2160@30Hz (4:2:2) 1920x1080@60Hz (4:4:4)
Audio formats	8 channel PCM Dolby Digital, Dolby Digital Plus, Dolby TrueHD, Dolby Atmos DTS, DTS-HD Master Audio 7.1, WMA Pro

* All standard VESA, CEA and other custom resolutions up to 600MHz (HDMI 2.0) are supported.

SFP+ Port Slots

Number of ports	2
Supported data rate	up to 10 Gbps
Accepted interfaces	10G SFP+ optical transceiver modules DAC cables

Audio Ports

The ports are available for the following models:

- UBEX-PRO20-HDMI-F110
- UBEX-PRO20-HDMI-F111
- UBEX-PRO20-HDMI-F120
- UBEX-PRO20-HDMI-F121
- UBEX-PRO20-HDMI-F130

Analog Audio Input

Audio port connector	5-pole Phoenix connector
Audio formats	2-channel PCM
Sampling frequency	48 kHz
Maximum input level	+0 dBu, 0.77 Vrms, 2.19 Vpp
Signal transmission	Balanced / unbalanced signal
Volume	-95 – 0 dB
Balance	-100 - +100 (0 = center)
Gain	-12 – 35 dB

Analog Audio Output

Audio port connector	5-pole Phoenix connector
Audio formats	2-channel PCM
Sampling frequency	48 kHz
Volume	-57 – 0 dB
Balance	-100 - +100 (0 = center)
Nominal Differential Output Level	+4 dBu @ 0 dB Gain
Nominal Differential Output Level	+7 dBu @ 3 dB Gain

Control Ports**Ethernet Port**

Number of ports - F100	2
Number of ports - F110 / F111 / F120 / F121 / F130	3
Connector type	Locking RJ45 female
Ethernet data rate	1000Base-T, full duplex with autodetect
Power over Ethernet (PoE)	Not supported

RS-232 Serial Port

The is available for the following models:

- UBEX-PRO20-HDMI-F110
- UBEX-PRO20-HDMI-F111
- UBEX-PRO20-HDMI-F120
- UBEX-PRO20-HDMI-F121
- UBEX-PRO20-HDMI-F130

Serial port connector	3-pole Phoenix connector
Available Baud rates	between 4800 and 115200
Available Data bits	8 or 9
Available Parity	None / Odd / Even
Available Stop bits	1 / 1.5 / 2

Infrared Port

The is available for the following models:

- UBEX-PRO20-HDMI-F110
- UBEX-PRO20-HDMI-F120

Input connector type	3.5 mm TRS (approx. 1/8" jack)
Output connector type	3.5 mm TS (approx. 1/8" jack)
Input carrier frequency	38 kHz
Output signal	modulated (38kHz) / not modulated (baseband)

USB-A Ports - F120 / F121 Models

The is available for the following models:

- UBEX-PRO20-HDMI-F120
- UBEX-PRO20-HDMI-F121

Connector type	USB Type-A receptacle
Number of ports	2
USB compliance	USB 2.0
Device class	HID

USB-A Ports - F130 Model

The is available for the following models:

- UBEX-PRO20-HDMI-F130

Connector type	USB Type-A receptacle
Number of ports (USB-HID / USB 2.0)	2 / 2
USB compliance	USB 2.0
Power supplement of all USB-A ports	5V, 1.7A (USB 2.0) / 5V, 0.3A (USB HID)
Maximum current supplement per USB-A port	1A

USB-C Port

The is available for the following models:

- UBEX-PRO20-HDMI-F121
- UBEX-PRO20-HDMI-F130

Connector type	Type-C receptacle
Number of ports- F121 model	1
Number of ports - F130 model (Host / USB 2.0)	1 / 2
USB compliance	USB 2.0

USB-B Port

The is available for the following models:

- UBEX-PRO20-HDMI-F120

Connector type	USB B-type receptacle
Number of ports	1
USB compliance	USB 2.0
Device class	HID

13.1.2. UBEX R-series Endpoints

General

Compliance	CE, UKCA
EMC (emission)	EN 55032:2015+A1:2020
EMC (immunity)	EN 55035:2017+A11:2020
RoHS	EN 63000:2018
Electrical safety	EN 62368-1:2020
Laser safety	EN 60825-1:2014+A11:2021
Warranty	3 years
Cooling	2x built-in fans
Operating temperature	0 to +50°C (+32 to +122°F)
Storage temperature	-40° to +85°C (-40° to +185°F)
Operating humidity	10% to 90%, non-condensing

Power Supply

AC power connector	Neutrik powerCON TRUE1 NAC3MPX-WOT receptacle
Power source	100-230 V AC, 50/60 Hz

Power Consumption / Heat Dissipation

Transmitted AV signals	Transmitter (TX) operation mode	Receiver (RX) operation mode	Transceiver (TRX) operation mode	Multiviewer (RXMV) operation mode
4K60	21.1 W	21.4 W	-	23.5 W
	72 BTU/h	73 BTU/h	-	80.2 BTU/h
4K30	20.3 W	20.2 W	-	-
	69.3 BTU/h	68.9 BTU/h	-	-
4K30 + 4K30	22.9 W	20.9 W	21.9 W	-
	78.1 BTU/h	71.3 BTU/h	74.7 BTU/h	-
4K60 + 1080p60	24.2 W	21.4 W	22.8 W	-
	82.6 BTU/h	73 BTU/h	77.8 BTU/h	-
4K60 + 4K30	22.1 W	21,1 W	21.6 W	-
	75.4 BTU/h	72 BTU/h	73.7 BTU/h	-

Enclosure

Rack mountable	Yes
Material	1 mm steel
Dimensions (mm/inch)	221W x 364D x 42.5H / 8.7W x 14.3D x 1.6H
Weight	2077 g (4,57 lbs)

Video Inputs

HDMI Input

Connector type	19-pole HDMI Type A receptacle
Number of ports	2
Standard	DVI 1.0, HDMI 2.0
Supported resolutions at 10 bits/color *	up to 4096x2160@60Hz (4:4:4) or 4096x2160@60Hz (4:2:2) up to 3840x2160@60Hz (4:4:4) or 3840x2160@60Hz (4:2:2)
Supported resolutions at 12 bits/color *	up to 4096x2160@60Hz (4:2:0) or 3840x2160@60Hz (4:2:0) up to 4096x2160@30Hz (4:2:2) or 3840x2160@30Hz (4:2:2) 1920x1080@60Hz (4:4:4)
Audio formats	8 channel PCM Dolby Digital, Dolby Digital Plus, Dolby TrueHD, Dolby Atmos DTS, DTS-HD Master Audio 7.1, WMA Pro

* All standard VESA, CEA and other custom resolutions up to 600MHz (HDMI 2.0) are supported.

Video Outputs**HDMI Output**

Connector type	19-pole HDMI Type A receptacle
Number of ports	2
Standard	DVI 1.0, HDMI 2.0
Supported resolutions at 10 bits/color *	up to 4096x2160@60Hz (4:4:4) or 4096x2160@60Hz (4:2:2) up to 3840x2160@60Hz (4:4:4) or 3840x2160@60Hz (4:2:2)
Supported resolutions at 12 bits/color *	up to 4096x2160@60Hz (4:2:0) or 3840x2160@60Hz (4:2:0) up to 4096x2160@30Hz (4:2:2) or 3840x2160@30Hz (4:2:2) 1920x1080@60Hz (4:4:4)
Audio formats	8 channel PCM Dolby Digital, Dolby Digital Plus, Dolby TrueHD, Dolby Atmos DTS, DTS-HD Master Audio 7.1, WMA Pro

* All standard VESA, CEA and other custom resolutions up to 600MHz (HDMI 2.0) are supported.

Fiber Optical Ports**2xMM-2xDUO**

Number of ports	2
Connector type	Neutrik opticalCON DUO NO2-4FDW-A
SFP+ modules in the enclosure	2x Finisar FTLX8574D3BCL
Optical mode	Multimode
Wavelength	850 nm

2xSM-2xDUO

Number of ports	2
Connector type	Neutrik opticalCON DUO NO2-4FDW-A
SFP+ modules in the enclosure	2x Finisar FTLX1475D3BCL
Optical mode	Singlemode
Wavelength	1310 nm

2xMM-QUAD

Number of ports	1
Connector type	Neutrik opticalCON QUAD NO4FDW-A
SFP+ modules in the enclosure	2x Finisar FTLX8574D3BCL
Optical mode	Multimode
Wavelength	850 nm

2xSM-QUAD

Number of ports	1
Connector type	Neutrik opticalCON QUAD NO4FDW-A
SFP+ modules in the enclosure	2x Finisar FTLX1475D3BCL
Optical mode	Singlemode
Wavelength	1310 nm

2xSM-BiDi-DUO

Number of ports	1
Connector type	Neutrik opticalCON DUO NO2-4FDW-A
SFP+ modules in the enclosure	1x Finisar FTLX2072D327 1x Finisar FTLX2072D333
Optical mode	Singlemode
Wavelength	1271 nm, 1331 nm

Control Ports**Ethernet Port**

Connector type	Neutrik etherCON NE8FDV-YK
Number of ports - 2xMM-2xDUO / 2xSM-2xDUO	1
Number of ports - 2xMM-QUAD / 2xSM-QUAD / 2xSM-BiDi-DUO	2
Ethernet data rate	1000Base-T, full duplex with autodetect
Power over Ethernet (PoE)	Not supported

13.2. Applied Ports (Network Settings)

The following ports are necessary to pass via a network switch/firewall for a proper working between the device and the softwares:

Purpose/function	Affected software	Protocol	Port nr.
Firmware update TFTP	LDU2	UDP	69
		UDP	50000
Device Discovery	LDC	UDP	224.0.0.251:5353
Remote IP	LDC	UDP	230.76.87.82:37421
LW3 protocol	-	TCP	6107
HTTP port	-	TCP	80
RS-232 command injection	-	TCP	8001, 8002
IR command injection	-	TCP	9001, 9002, 9003, 9004
USB 2.0 discovery (F130 model only)	-	UDP	6137, 6971
USB KVM connection between the F130 endpoints	-	UDP	6973

13.3. Maximum Cable Extensions

13.3.1. F-series Endpoints

The maximum fiber cable extension of the F-series endpoint devices depends on the installed SFP+ modules. Always read the specification of the modules.

10GBASE-T SFP+ Copper RJ45 Modules

F-series endpoint devices can be installed with 10GBASE-T SFP+ to RJ45 modules. Lightware recommends FS 10GBASE-T SFP+ Copper RJ-45 (Juniper Networks EX-SFP-10GE-T Compatible) transceiver module which is able to apply **up to 80 meters** cable extension in case of CAT6A or CAT7 (AWG24 or higher category) 10G Ethernet cable types.

ATTENTION: Always apply **equal length** copper cables for both SFP+ to RJ45 modules in case of 20G signal transmission. Different cable lengths may cause data package loss.

TIPS AND TRICKS: AWG number shows the quality of the copper cable. The number is smaller, the quality of the cable is better and its resistance is even smaller. Smaller resistance makes possible applying longer cable.

13.3.2. R-series Endpoint

The R-series endpoint devices are built with pre-installed SFP+ modules inside the enclosure. The maximum fiber cable extension depends on the modules. The SFP+ modules can be changed by the user, see the details in the [SFP+ Module Changing in R-series Endpoints](#) section.

2xMM-2xDUO / 2xMM-QUAD

Multimode fiber optical cables			
OM1 (62.5/125)	OM2 (50/125)	OM3 (50/125)	OM4 (50/125)
Not supported		300 m	400 m

2xSM-2xDUO / 2xSM-QUAD / 2xSM-BiDi-DUO

Singlemode fiber optical cables	
OS1 (62.5/125)	OS2 (50/125)
2000 m	10000 m

13.4. Input/Output Port Numbering

13.4.1. F100 / R100 - TX Mode

Description		Video port nr. (LW3)	Audio port nr. (LW3)
HDMI ports	HDMI in 1	I1	I1
	HDMI in 2	I2	I2
	HDMI out 1 (local out 1)	O1	O1
	HDMI out 2 (local out 2)	O2	O2
	Stream 1 - Processed stream from HDMI in 1	S1	S1
Source streams	Stream 2 - Processed stream from HDMI in 2	S2	S2
	Stream 3 - Native stream from HDMI in 1	S3	S1
	Stream 4 - Native stream from HDMI in 2	S4	S2
	Stream 1	D1	D1
Destination streams	Stream 2	D2	D2

13.4.2. F100 / R100 - RX Mode

Description		Video port nr. (LW3)	Audio port nr. (LW3)
HDMI ports	HDMI in 1 (local in 1)	I1	I1
	HDMI in 2 (local in 2)	I2	I2
	HDMI out 1	O1	O1
	HDMI out 2	O2	O2
Source streams	Stream 1 - Processed (from the (HDMI in 1 of the remote device)	S1	S1
	Stream 2 - Processed (from the (HDMI in 2 of the remote device)	S2	S2
	Stream 1 - Native (from the (HDMI in 1 of the remote device)	S3	S3
	Stream 2 - Native (from the (HDMI in 2 of the remote device)	S4	S4
Destination streams	Stream 1	D1	D1
	Stream 2	D2	D2
	Remote device stream 1	D3	D3
	Remote device stream 2	D4	D4

13.4.3. F100 / R100 - TRX Mode

Description		Video port nr. (LW3)	Audio port nr. (LW3)
HDMI ports	HDMI in 2	I2	I2
	HDMI out 1	O1	O1
	HDMI out 2 (local output)	O2	O2
Source streams	Stream 1 (from HDMI in 2)	S1	S1
	Stream 2 (from the remote device)	S2	S2
Destination streams	Stream 1 (toward HDMI out 2)	D1	D1
	Stream 2 (toward the remote device)	D2	D2

13.4.4. F100 / R100 - RXMV Mode

Description		Video port nr. (LW3)	Audio port nr. (LW3)
HDMI ports	HDMI out 1 (Multiviewer - MV1)	O1	O1
	Tile #1	T1	-
	Tile #2	T2	-
	Tile #3	T3	-
	Tile #4	T4	-
HDMI out 2		O2	O2
Source streams	Stream 1 - Processed (from the (HDMI in 1 of the remote device)	S1	S1
	Stream 2 - Processed (from the (HDMI in 2 of the remote device)	S2	S2
	Stream 1 - Native (from the (HDMI in 1 of the remote device)	S3	S1
	Stream 2 - Native (from the (HDMI in 2 of the remote device)	S4	S2
Destination streams	Stream for T1 tile on O1 port	D1	D1
	Stream for T2 tile on O1 port	D2	
	Stream for T3 tile on O1 port	D3	
	Stream for T4 tile on O1 port	D4	
	Stream on O2 port	D5	D2

13.4.5. F110 / F111 / F120 / F121 / F130 - TX Mode

Audio-Video Port Numbering Table

Description		Video port nr. (LW3)	Audio port nr. (LW3)
HDMI ports	HDMI in 2	I2	I2
	HDMI out 1	O1	O1
	HDMI out 2 (local output)	O2	O2
Analog audio ports	Analog audio in	-	I3
	Analog audio out	-	O3
Source streams	Stream 1 - Processed stream from HDMI in 1	S1	S1
	Stream 2 - Processed stream from HDMI in 2	S2	S2
	Stream 3 - Native stream from HDMI in 1	S3	S1
	Stream 4 - Native stream from HDMI in 2	S4	S2
	Analog audio input stream	-	S3
	Remote audio input stream	-	S4
Destination streams	Analog audio output stream	-	D1
	HDMI stream 1	D1	D2
	HDMI stream 2	D2	D3
	Remote audio output stream	-	D4

13.4.6. F110 / F111 / F120 / F121 / F130 - RX Mode

Audio-Video Port Numbering Table

Description		Video port nr. (LW3)	Audio port nr. (LW3)
HDMI ports	HDMI out 1	O1	O1
	HDMI out 2	O2	O2
Analog audio ports	Analog audio in	-	I3
	Analog audio out	-	O3
Source streams	Analog audio input stream	-	S1
	Stream 1 - Processed (from the (HDMI in 1 of the remote device)	S1	S2
	Stream 2 - Processed (from the (HDMI in 2 of the remote device)	S2	S3
	Stream 1 - Native (from the (HDMI in 1 of the remote device)	S3	S2
	Stream 2 - Native (from the (HDMI in 2 of the remote device)	S4	S3
	Remote audio input stream	-	S4
Destination streams	Stream 1	D1	D1
	Stream 2	D2	D2
	Analog audio output stream	-	D3
	Remote audio output stream	-	D4
	Remote device stream 1	D5	D5
	Remote device stream 2	D6	D6

13.4.7. F110 / F111 / F120 / F121 / F130 - TRX Mode

Audio-Video Port Numbering Table

Description		Video port nr. (LW3)	Audio port nr. (LW3)
HDMI ports	HDMI in 2	I2	I2
	HDMI out 1	O1	O1
	HDMI out 2	O2	O2
Analog audio ports	Analog audio in	-	I3
	Analog audio out	-	O3
Source streams	HDMI stream 1 (from HDMI in 2)	S1	S1
	Analog audio input stream	-	S2
	HDMI stream 2 (from the remote device)	S2	S3
	Remote audio input stream	-	S4
Destination streams	HDMI stream 1 (toward HDMI out 1)	D1	D1
	Analog audio output stream	-	D2
	HDMI stream 2 (toward the remote device)	D2	D3
	Remote audio output stream	-	D4

13.4.8. F110 / F111 / F120 / F121 / F130 - RXMV Mode

Audio-Video Port Numbering Table

Description		Video port nr. (LW3)	Audio port nr. (LW3)
HDMI ports	HDMI out 1	O1	O1
	Tile #1	T1	-
	Tile #2	T2	-
	HDMI out 2	O2	O2
Analog audio ports	Analog audio in	-	I3
	Analog audio out	-	O3
Source streams	Analog audio input stream	-	S1
	Stream 1 - Processed (from the (HDMI in 1 of the remote device)	S1	S2
	Stream 2 - Processed (from the (HDMI in 2 of the remote device)	S2	S3
	Stream 1 - Native (from the (HDMI in 1 of the remote device)	S3	S2
	Stream 2 - Native (from the (HDMI in 2 of the remote device)	S4	S3
	Remote audio input stream	-	S4
Destination streams	Stream for T1 tile on O1 port	D1	D1
	Stream for T2 tile on O1 port	D2	
	Stream for T3 tile on O1 port	D3	
	Stream for T4 tile on O1 port	D4	D2
	Stream on O2 port	D5	
	Analog audio output stream	-	D3
	Remote audio output stream	-	D4

13.4.9. Control Port Numbering

UBEX-PRO20-HDMI-F100 / R100 series

The port numbering is valid for all operation modes (TX / RX / TRX / RXMV).

Description		Port number
Ethernet	Gigabit Ethernet 1	P1
	Gigabit Ethernet 2	P2

UBEX-PRO20-HDMI-F110 / UBEX-PRO20-HDMI-F111

The port numbering is valid for all operation modes (TX / RX / TRX / RXMV).

Description		Port number
Ethernet	Gigabit Ethernet 1	P1
	Gigabit Ethernet 2	P2
	Gigabit Ethernet 3	P3
Serial	RS-232	P1

UBEX-PRO20-HDMI-F120

The port numbering is valid for all operation modes (TX / RX / TRX / RXMV).

Description		Port number
Ethernet	Gigabit Ethernet 1	P1
	Gigabit Ethernet 2	P2
	Gigabit Ethernet 3	P3
Serial	RS-232	P1
USB K+M	Local emulated (source; USB-A) port of the endpoint	E1
	Remote emulated (source; USB-A) port of the endpoint	E2
	Downstream - signal of the right (M) USB-A device	D1
	Downstream - signal of the left (K) USB-A device	D2
	Local receiver (destination; USB-B) port of the endpoint	R1
	Remote receiver (destination; USB-B) port of the endpoint	R2
	Upstream - signal of the local USB-B device	U1

UBEX-PRO20-HDMI-F121

The port numbering is valid for all operation modes (TX / RX / TRX / RXMV).

Description		Port number
Ethernet	Gigabit Ethernet 1	P1
	Gigabit Ethernet 2	P2
	Gigabit Ethernet 3	P3
Serial	RS-232	P1
USB K+M	Local emulated (source; USB-A) port of the endpoint	E1
	Remote emulated (source; USB-A) port of the endpoint	E2
	Downstream - signal of the right (M) USB-A device	D1
	Downstream - signal of the left (K) USB-A device	D2
	Local receiver (Host; USB-C) port of the endpoint	R1
	Remote receiver (Host; USB-C) port of the endpoint	R2
	Upstream - signal of the local USB-C device	U1

UBEX-PRO20-HDMI-F130

The port numbering is valid for all operation modes (TX / RX / TRX / RXMV).

Description		Port number
Ethernet	Gigabit Ethernet 1	P1
	Gigabit Ethernet 2	P2
	Gigabit Ethernet 3	P3
Serial	RS-232	P1
USB KVM / USB 2.0	Local emulated (source; USB HID) port of the endpoint	E1
	Remote emulated (source; USB HID) port of the endpoint	E2
	Downstream - signal of the right (M) USB HID device	D1
	Downstream - signal of the left (K) USB HID device	D2
	Local receiver (Host; USB-C) port of the endpoint	R1
	Remote receiver (Host; USB-C) port of the endpoint	R2
	Upstream - signal of the local USB-C host device	U1

13.5. Factory Default Settings

13.5.1. UBEX-PRO20-HDMI-F100 / R100 series

Parameter	Setting/Value
General settings	
Device label (F100)	UBEX-PRO20-HDMI-F100
Device label (R100 series)	UBEX-PRO20-HDMI-R100 <variant>
Operation mode	Keeps the current operation mode
Display backlight	10
Jog dial rotary direction	Clockwise (CW down)
Video input port settings (TX - HDMI in 1 and 2 / TRX - HDMI in 2)	
HDCP authentication	Enabled
Stream enable	Enabled
Emulated EDID on the inputs	Dynamic
Video output port settings (RX - HDMI out 1 and 2 / TRX - HDMI out 1 / RXMV - HDMI out 1 and 2)	
HDCP mode	Depends on input (Auto)
Power 5V mode	Always on
Timing mode	Free run
No sync screen mode	Always off
No sync screen color	R: 128, G: 128, B: 128 (grey)
Local video input port settings (RX - HDMI in 1 and 2 / RXMV - HDMI in 1 and 2)	
HDCP authentication	Enabled
Emulated EDID on the inputs	Dynamic
Local video output port settings (TX - HDMI out 1 and 2 / TRX - HDMI out 2)	
HDCP mode	Auto
Power 5V mode	Always on
No sync screen mode	Always off
No sync screen color	R: 128, G: 128, B: 128 (grey)
Source MUX settings	
RX - HDMI out 1	Stream (D1)
RX - HDMI out 2	Stream (D2)
TRX - HDMI out 2	HDMI in 2 (I2)

Parameter	Setting/Value
Scaler settings (TX - HDMI in 1 and 2 / RX - HDMI out 1 and 2 / RXMV - HDMI out 2 / TRX - HDMI in 2 and HDMI out 1)	
Scaler enable	Disabled (Passthrough mode)
Scale to	1920x1080p60
Image position	Fit
Color space conversion (CSC)	No conversion
Color range	No conversion
Color depth	Passthrough
Multiviewer settings (RXMV - HDMI out 1)	
Canvas resolution	3840x2160p60
Color depth	8 bpc
Tile layer order	1;2;3;4
Tile enabled	True
Tile positions (T1 / T2)	0,0 / 1920,0
Tile size	1920x1080
Tile opacity	100%
Network settings	
Static IP address - TX / TRX mode	192.168.0.101
Static IP address - RX / RXMV mode	192.168.0.102
DHCP (dynamic IP address)	Disabled
Subnet mask	255.255.255.0
Static gateway	192.168.0.1
LW3 port number	6107
HTTP port number	80
Miscellaneous	
Application mode	Auto
Dark mode	Disabled
Control lock	Disabled
Unique port names	Cleared
Unique device label	Cleared
User EDIDs	Not cleared

13.5.2. UBEX-PRO20-HDMI-F110 / F111

Parameter	Setting/Value
General settings	
Device label (F110)	UBEX-PRO20-HDMI-F110
Device label (F111)	UBEX-PRO20-HDMI-F111
Operation mode	Keeps the current operation mode
Display backlight	10
Jog dial rotary direction	Clockwise (CW down)
Video input port settings (TX - HDMI in 1 and 2 / TRX - HDMI in 2)	
HDCP authentication	Enabled
Stream enable	Enabled
Emulated EDID on the inputs	Dynamic
Video output port settings (RX - HDMI out 1 and 2 / RXMV - HDMI out 1 and 2 / TRX - HDMI out 1)	
HDCP mode	Depends on input (Auto)
Power 5V mode	Always on
Timing mode	Free run
No sync screen mode	Always off
No sync screen color	R: 128, G: 128, B: 128 (grey)
Local video input port settings (RX - HDMI in 1 and 2 / RXMV - HDMI in 1 and 2)	
HDCP authentication	Enabled
Emulated EDID on the inputs	Dynamic
Local video output port settings (TX - HDMI out 1 and 2 / TRX - HDMI out 2)	
HDCP mode	Auto
Power 5V mode	Always on
No sync screen mode	Always off
No sync screen color	R: 128, G: 128, B: 128 (grey)
Color depth	Passthrough
Source MUX settings	
RX - HDMI out 1	Stream (D1)
RX - HDMI out 2	Stream (D2)
TRX - HDMI out 2	HDMI in 2 (I2)
Scaler settings (TX - HDMI in 1 and 2 / RX - HDMI out 1 and 2 / RXMV - HDMI out 2 / TRX - HDMI in 2 and HDMI out 1)	
Scaler enable	Disabled (Pass-through mode)
Scale to	1920x1080p60
Image position	Fit
Color space conversion (CSC)	No conversion
Color depth	Passthrough

Parameter	Setting/Value
Multiviewer settings (RXMV - HDMI out 1)	
Canvas resolution	3840x2160p60
Color depth	8 bpc
Tile layer order	1;2;3;4
Tile enabled	True
Tile positions (T1 / T2)	0,0 / 1920,0
Tile size	1920x1080
Tile opacity	100%
Analog audio input port properties	
Volume	0.00 dB (100%)
Balance	0 (center)
Gain	0.00 dB
Analog audio output port properties	
Volume	0.00 dB (100%)
Balance	0 (center)
Network settings	
Static IP address - TX/TRX mode	192.168.0.101
Static IP address - RX/RXMV mode	192.168.0.102
DHCP (dynamic IP address)	Disabled
Subnet mask	255.255.255.0
Static gateway	192.168.0.1
LW3 port number	6107
HTTP port number	80
RS-232 port settings	
Operation mode	Command injection
TCP port	8001
Configuration	57600 BAUD 8N1
Miscellaneous	
Application mode	Auto
Dark mode	Disabled
Control lock	Disabled
Unique port names	Cleared
Unique device label	Cleared
User EDIDs	Not cleared

13.5.3. UBEX-PRO20-HDMI-F120 / F121

Parameter	Setting/Value
General settings	
Device label (F120)	UBEX-PRO20-HDMI-F120
Device label (F121)	UBEX-PRO20-HDMI-F121
Operation mode	Keeps the current operation mode
Display backlight	10
Jog dial rotary direction	Clockwise (CW down)
Video input port settings (TX - HDMI in 1 and 2 / TRX - HDMI in 2)	
HDCP authentication	Enabled
Stream enable	Enabled
Emulated EDID on the inputs	Dynamic
Video output port settings (RX - HDMI out 1 and 2 / RXMV - HDMI out 1 and 2 / TRX - HDMI out 1)	
HDCP mode	Depends on input (Auto)
Power 5V mode	Always on
Timing mode	Free run
No sync screen mode	Always off
No sync screen color	R: 128, G: 128, B: 128 (grey)
Local video input port settings (RX - HDMI in 1 and 2 / RXMV - HDMI in 1 and 2)	
HDCP authentication	Enabled
Emulated EDID on the inputs	Dynamic
Local video output port settings (TX - HDMI out 1 and 2 / TRX - HDMI out 2)	
HDCP mode	Auto
Power 5V mode	Always on
No sync screen mode	Always off
No sync screen color	R: 128, G: 128, B: 128 (grey)
Scaler settings (TX - HDMI in 1 and 2 / RX - HDMI out 1 and 2 / RXMV - HDMI out 2 / TRX - HDMI in 2 and HDMI out 1)	
Scaler enable	Disabled (Pass-through mode)
Scale to	1920x1080p60
Image position	Fit
Color space conversion (CSC)	No conversion
Color depth	Passthrough
Color depth	Passthrough
Source MUX settings	
RX - HDMI out 1	Stream (D1)
RX - HDMI out 2	Stream (D2)
TRX - HDMI out 2	HDMI in 2 (I2)

Parameter	Setting/Value
Multiviewer settings (RXMV - HDMI out 1)	
Canvas resolution	3840x2160p60
Color depth	8 bpc
Tile layer order	1;2;3;4
Tile enabled	True
Tile positions (T1 / T2)	0,0 / 1920,0
Tile size	1920x1080
Tile opacity	100%
Analog audio input port properties	
Volume	0.00 dB (100%)
Balance	0 (center)
Gain	0.00 dB
Analog audio output port properties	
Volume	0.00 dB (100%)
Balance	0 (center)
Network settings	
Static IP address - TX mode	192.168.0.101
Static IP address - RX mode	192.168.0.102
Static IP address - TRX mode	192.168.0.101
DHCP (dynamic IP address)	Disabled
Subnet mask	255.255.255.0
Static gateway	192.168.0.1
LW3 port number	6107
HTTP port number	80
RS-232 port settings	
Operation mode	Command injection
TCP port	8001
Configuration	57600 BAUD 8N1
USB K+M	
Remote/Local control mode	Remote
Miscellaneous	
Application mode	Auto
Dark mode	Disabled
Control lock	Disabled
Unique port names	Cleared
Unique device label	Cleared
User EDIDs	Not cleared

13.5.4. UBEX-PRO20-HDMI-F130

Parameter	Setting/Value
General settings	
Device label	UBEX-PRO20-HDMI-F130
Operation mode	Keeps the current operation mode
Display backlight	10
Jog dial rotary direction	Clockwise (CW down)
Video input port settings (TX - HDMI in 1 and 2 / TRX - HDMI in 2)	
HDCP authentication	Enabled
Stream enable	Enabled
Emulated EDID on the inputs	Dynamic
Video output port settings (RX - HDMI out 1 and 2 / RXMV - HDMI out 1 and 2 / TRX - HDMI out 1)	
HDCP mode	Depends on input (Auto)
Power 5V mode	Always on
Timing mode	Free run
No sync screen mode	Always off
No sync screen color	R: 128, G: 128, B: 128 (grey)
Local video input port settings (RX - HDMI in 1 and 2 / RXMV - HDMI in 1 and 2)	
HDCP authentication	Enabled
Emulated EDID on the inputs	Dynamic
Local video output port settings (TX - HDMI out 1 and 2 / TRX - HDMI out 2)	
HDCP mode	Auto
Power 5V mode	Always on
No sync screen mode	Always off
No sync screen color	R: 128, G: 128, B: 128 (grey)
Scaler settings (TX - HDMI in 1 and 2 / RX - HDMI out 1 and 2 / RXMV - HDMI out 2 / TRX - HDMI in 2 and HDMI out 1)	
Scaler enable	Disabled (Pass-through mode)
Scale to	1920x1080p60
Image position	Fit
Color space conversion (CSC)	No conversion
Color depth	Passthrough
Color depth	Passthrough
Source MUX settings	
RX - HDMI out 1	Stream (D1)
RX - HDMI out 2	Stream (D2)
TRX - HDMI out 2	HDMI in 2 (I2)

Parameter	Setting/Value
Multiviewer settings (RXMV - HDMI out 1)	
Canvas resolution	3840x2160p60
Color depth	8 bpc
Tile layer order	1;2;3;4
Tile enabled	True
Tile positions (T1 / T2)	0,0 / 1920,0
Tile size	1920x1080
Tile opacity	100%
Analog audio input port properties	
Volume	0.00 dB (100%)
Balance	0 (center)
Gain	0.00 dB
Analog audio output port properties	
Volume	0.00 dB (100%)
Balance	0 (center)
Network settings	
Static IP address - TX mode	192.168.0.101
Static IP address - RX mode	192.168.0.102
Static IP address - TRX mode	192.168.0.101
DHCP (dynamic IP address)	Disabled
Subnet mask	255.255.255.0
Static gateway	192.168.0.1
LW3 port number	6107
HTTP port number	80
RS-232 port settings	
Operation mode	Command injection
TCP port	8001
Configuration	57600 BAUD 8N1
USB KVM	
USB HID mode	Local
USB 2.0 LEX / REX mode	LEX (Local)
Miscellaneous	
Application mode	Auto
Dark mode	Disabled
Control lock	Disabled
Unique port names	Cleared
Unique device label	Cleared
User EDIDs	Not cleared

13.6. Content of Backup File

The backup file contains numerous settings and parameters saved from the device. When the file is uploaded to a device, the following will be overwritten.

For the procedure of the backup and restore function, see the details in the [Configuration Cloning \(Backup Tab\)](#) section.

13.6.1. F100 / R100 - Transmitter Mode

General
Operation mode setting, Application mode selection setting
Device label
Crosspoint settings
Video stream switch state, Audio stream switch state
HDMI input ports
Video port name
HDCP setting
Stream settings
Enable/disable status
Color space conversion setting
Scaler settings
Enable/disable status, Resolution setting, Image position
Color space conversion setting, color range setting, color depth setting, color depth setting
HDMI output ports
Port name, HDCP mode, Power +5V mode, Color depth setting
Ethernet ports
Enable/disable status, Mode setting
Static IP address, Network mask, Gateway address
DHCP status (enable / disable)
Miscellaneous settings
Device label, Control lock status
Display brightness, Jog dial rotary direction, Fan setting
User EDID data (U1-U12), Emulated EDIDs by ports

13.6.2. F100 / R100 - Receiver Mode

General
Operation mode setting, Application mode selection setting
Device label
Crosspoint settings
Video stream switch state, Audio stream switch state
Stream settings
Enable/disable status
Color space conversion setting
Scaler settings
Enable/disable status, Resolution setting, Image position
Color space conversion setting, color range setting, color depth setting
HDMI output ports
Port name, HDCP mode, Power +5V mode, Color depth setting
No sync screen mode, No sync screen color
Ethernet ports
Enable/disable status, Mode setting
Static IP address, Network mask, Gateway address
DHCP status (enable / disable)
Miscellaneous settings
Device label, Control lock status
Display brightness, Jog dial rotary direction, Fan setting
User EDID data (U1-U12), Emulated EDIDs by ports

13.6.3. F100 / R100 - Transceiver Mode

General
Operation mode setting, Application mode selection setting
Device label
Crosspoint settings
Video stream switch state, Audio stream switch state
HDMI input port
Video port name
HDCP setting
Stream settings
Enable/disable status
Color space conversion setting
Scaler settings
Enable/disable status, Resolution setting, Image position
Color space conversion setting, color range setting, color depth setting
HDMI output ports
Port name, HDCP mode, Power +5V mode, Color depth setting
No sync screen mode, No sync screen color
Ethernet ports
Enable/disable status, Mode setting
Static IP address, Network mask, Gateway address
DHCP status (enable / disable)
Miscellaneous settings
Device label, Control lock status
Display brightness, Jog dial rotary direction, Fan setting
User EDID data (U1-U12), Emulated EDIDs by ports

13.6.4. F100 / R100 - Multiviewer Mode

General
Operation mode setting, Application mode selection setting
Device label
Crosspoint settings
Video stream switch state, Audio stream switch state
Stream settings
Enable/disable status
Color space conversion setting
Multiviewer settings
Tile enable/disable status, Canvas resolution setting, Tile size, Tile position, Tile opacity
Color depth setting
Scaler settings
Enable/disable status, Resolution setting, Image position
Color space conversion setting, color range setting
HDMI output ports
Port name, HDCP mode, Power +5V mode, Color depth setting
No sync screen mode, No sync screen color
Ethernet ports
Enable/disable status, Mode setting
Static IP address, Network mask, Gateway address
DHCP status (enable / disable)
Miscellaneous settings
Device label, Control lock status
Display brightness, Jog dial rotary direction, Fan setting
User EDID data (U1-U12), Emulated EDIDs by ports

13.6.5. F110 / F111 - Transmitter Mode

General
Operation mode setting, Application mode selection setting
Device label
Crosspoint settings
Video stream switch state, Audio stream switch state
HDMI input ports
Video port name, HDCP setting
Stream settings
Enable/disable status, Color space conversion setting
Scaler settings
Enable/disable status, Resolution setting, Image position
Color space conversion setting, color range setting, color depth setting
HDMI output ports
Port name, HDCP mode, Power +5V mode, Color depth setting
Analog audio input port
Port name, Volume, Balance, Gain settings
Analog audio output port
Port name, Mute state, Volume, Balance, Gain settings
Ethernet ports
Enable/disable status, Mode setting
Static IP address, Network mask, Gateway address
DHCP status (enable / disable)
RS-232 port
Port name, Command injection status, Command injection port nr.
Baud rate, Data bits, Parity, Stop bits
Miscellaneous settings
Device label, Control lock status
Display brightness, Jog dial rotary direction, Fan setting
User EDID data (U1-U12), Emulated EDIDs by ports

13.6.6. F110 / F111 - Receiver Mode

General
Operation mode setting, Application mode selection setting
Device label
Crosspoint settings
Video stream switch state, Audio stream switch state
Stream settings
Enable/disable status, Color space conversion setting
Scaler settings
Enable/disable status, Resolution setting, Image position
Color space conversion setting, color range setting
HDMI output ports
Port name, HDCP mode, Power +5V mode, Color depth setting
No sync screen mode, No sync screen color
Analog audio input port
Port name, Volume, Balance, Gain settings
Analog audio output port
Port name, Mute state, Volume, Balance, Gain settings
Ethernet ports
Enable/disable status, Mode setting
Static IP address, Network mask, Gateway address
DHCP status (enable / disable)
RS-232 port
Port name, Command injection status, Command injection port nr.
Baud rate, Data bits, Parity, Stop bits
Miscellaneous settings
Device label, Control lock status
Display brightness, Jog dial rotary direction, Fan setting
User EDID data (U1-U12), Emulated EDIDs by ports

13.6.7. F110 / F111 - Transceiver Mode

General
Operation mode setting, Application mode selection setting
Device label
Crosspoint settings
Video stream switch state, Audio stream switch state
HDMI input port
Video port name, HDCP setting
Stream settings
Enable/disable status, Color space conversion setting
Scaler settings
Enable/disable status, Resolution setting, Image position
Color space conversion setting, color range setting, color depth setting
HDMI output ports
Port name, HDCP mode, Power +5V mode, Color depth setting
No sync screen mode, No sync screen color
Analog audio input port
Port name, Volume, Balance, Gain settings
Analog audio output port
Port name, Mute state, Volume, Balance, Gain settings
Ethernet ports
Enable/disable status, Mode setting
Static IP address, Network mask, Gateway address
DHCP status (enable / disable)
RS-232 port
Port name, Command injection status, Command injection port nr.
Baud rate, Data bits, Parity, Stop bits
Miscellaneous settings
Device label, Control lock status
Display brightness, Jog dial rotary direction, Fan setting
User EDID data (U1-U12), Emulated EDIDs by ports

13.6.8. F110 / F111 - Multiviewer Mode

General
Operation mode setting, Application mode selection setting
Device label
Crosspoint settings
Video stream switch state, Audio stream switch state
Stream settings
Enable/disable status, Color space conversion setting
Scaler settings
Enable/disable status, Resolution setting, Image position
Color space conversion setting, color range setting
Multiviewer settings
Tile enable/disable status, Canvas resolution setting, Tile size, Tile position, Tile opacity
Color depth setting
HDMI output ports
Port name, HDCP mode, Power +5V mode, Color depth setting
No sync screen mode, No sync screen color
Analog audio input port
Port name, Volume, Balance, Gain settings
Analog audio output port
Port name, Mute state, Volume, Balance, Gain settings
Ethernet ports
Enable/disable status, Mode setting
Static IP address, Network mask, Gateway address
DHCP status (enable / disable)
RS-232 port
Port name, Command injection status, Command injection port nr.
Baud rate, Data bits, Parity, Stop bits
Miscellaneous settings
Device label, Control lock status
Display brightness, Jog dial rotary direction, Fan setting
User EDID data (U1-U12), Emulated EDIDs by ports

13.6.9. F120 / F121 - Transmitter Mode

General
Operation mode setting, Application mode selection setting
Device label
Crosspoint settings
Video stream switch state, Audio stream switch state
HDMI input ports
Video port name, HDCP setting
Stream settings
Enable/disable status, Color space conversion setting
Scaler settings
Enable/disable status, Resolution setting, Image position
Color space conversion setting, color range setting, color depth setting
HDMI output ports
Port name, HDCP mode, Power +5V mode, Color depth setting
Analog audio input port
Port name, Volume, Balance, Gain settings
Analog audio output port
Port name, Mute state, Volume, Balance, Gain settings
Ethernet ports
Enable/disable status, Mode setting
Static IP address, Network mask, Gateway address
DHCP status (enable / disable)
RS-232 port
Port name, Command injection status, Command injection port nr.
Baud rate, Data bits, Parity, Stop bits
USB K+M settings
Port names, Enable/disable status, Local/Remote mode setting
Miscellaneous settings
Device label, Control lock status
Display brightness, Jog dial rotary direction, Fan setting
User EDID data (U1-U12), Emulated EDIDs by ports

13.6.10. F120 / F121 - Receiver Mode

General
Operation mode setting, Application mode selection setting
Device label
Crosspoint settings
Video stream switch state, Audio stream switch state
Stream settings
Enable/disable status, Color space conversion setting
Scaler settings
Enable/disable status, Resolution setting, Image position
Color space conversion setting, color range setting
HDMI output ports
Port name, HDCP mode, Power +5V mode, Color depth setting
No sync screen mode, No sync screen color
Analog audio input port
Port name, Volume, Balance, Gain settings
Analog audio output port
Port name, Mute state, Volume, Balance, Gain settings
Ethernet ports
Enable/disable status, Mode setting
Static IP address, Network mask, Gateway address
DHCP status (enable / disable)
RS-232 port
Port name, Command injection status, Command injection port nr.
Baud rate, Data bits, Parity, Stop bits
USB K+M settings
Port names, Enable/disable status, Local/Remote mode setting
Miscellaneous settings
Device label, Control lock status
Display brightness, Jog dial rotary direction, Fan setting
User EDID data (U1-U12), Emulated EDIDs by ports

13.6.11. F120 / F121 - Transceiver Mode

General
Operation mode setting, Application mode selection setting
Device label
Crosspoint settings
Video stream switch state, Audio stream switch state
HDMI input port
Video port name, HDCP setting
Stream settings
Enable/disable status, Color space conversion setting
Scaler settings
Enable/disable status, Resolution setting, Image position
Color space conversion setting, color range setting, color depth setting
HDMI output ports
Port name, HDCP mode, Power +5V mode, Color depth setting
No sync screen mode, No sync screen color
Analog audio input port
Port name, Volume, Balance, Gain settings
Analog audio output port
Port name, Mute state, Volume, Balance, Gain settings
Ethernet ports
Enable/disable status, Mode setting
Static IP address, Network mask, Gateway address
DHCP status (enable / disable)
RS-232 port
Port name, Command injection status, Command injection port nr.
Baud rate, Data bits, Parity, Stop bits
USB K+M settings
Port names, Enable/disable status, Local/Remote mode setting
Miscellaneous settings
Device label, Control lock status
Display brightness, Jog dial rotary direction, Fan setting
User EDID data (U1-U12), Emulated EDIDs by ports

13.6.12. F120 / F121 - Multiviewer Mode

General
Operation mode setting, Application mode selection setting
Device label
Crosspoint settings
Video stream switch state, Audio stream switch state
Stream settings
Enable/disable status, Color space conversion setting
Scaler settings
Enable/disable status, Resolution setting, Image position
Color space conversion setting, color range setting
Multiviewer settings
Tile enable/disable status, Canvas resolution setting, Tile size, Tile position, Tile opacity
Color depth setting
HDMI output ports
Port name, HDCP mode, Power +5V mode, Color depth setting
No sync screen mode, No sync screen color
Analog audio input port
Port name, Volume, Balance, Gain settings
Analog audio output port
Port name, Mute state, Volume, Balance, Gain settings
Ethernet ports
Enable/disable status, Mode setting
Static IP address, Network mask, Gateway address
DHCP status (enable / disable)
RS-232 port
Port name, Command injection status, Command injection port nr.
Baud rate, Data bits, Parity, Stop bits
USB K+M settings
Port names, Enable/disable status, Local/Remote mode setting
Miscellaneous settings
Device label, Control lock status
Display brightness, Jog dial rotary direction, Fan setting
User EDID data (U1-U12), Emulated EDIDs by ports

13.6.13. F130 - Transmitter Mode

General
Operation mode setting, Application mode selection setting
Device label
Crosspoint settings
Video stream switch state, Audio stream switch state
HDMI input ports
Video port name, HDCP setting
Stream settings
Enable/disable status, Color space conversion setting
Scaler settings
Enable/disable status, Resolution setting, Image position
Color space conversion setting, color range setting, color depth setting
HDMI output ports
Port name, HDCP mode, Power +5V mode, Color depth setting
Analog audio input port
Port name, Volume, Balance, Gain settings
Analog audio output port
Port name, Mute state, Volume, Balance, Gain settings
Ethernet ports
Enable/disable status, Mode setting
Static IP address, Network mask, Gateway address
DHCP status (enable / disable)
RS-232 port
Port name, Command injection status, Command injection port nr.
Baud rate, Data bits, Parity, Stop bits
USB KVM settings
Port names, Enable/disable status
USB HID Local/Remote mode setting, USB 2.0 LEX / REX mode setting
Miscellaneous settings
Device label, Control lock status
Display brightness, Jog dial rotary direction, Fan setting
User EDID data (U1-U12), Emulated EDIDs by ports

13.6.14. F130 - Receiver Mode

General
Operation mode setting, Application mode selection setting
Device label
Crosspoint settings
Video stream switch state, Audio stream switch state
Stream settings
Enable/disable status, Color space conversion setting
Scaler settings
Enable/disable status, Resolution setting, Image position
Color space conversion setting, color range setting
HDMI output ports
Port name, HDCP mode, Power +5V mode, Color depth setting
No sync screen mode, No sync screen color
Analog audio input port
Port name, Volume, Balance, Gain settings
Analog audio output port
Port name, Mute state, Volume, Balance, Gain settings
Ethernet ports
Enable/disable status, Mode setting
Static IP address, Network mask, Gateway address
DHCP status (enable / disable)
RS-232 port
Port name, Command injection status, Command injection port nr.
Baud rate, Data bits, Parity, Stop bits
USB KVM settings
Port names, Enable/disable status
USB HID Local/Remote mode setting, USB 2.0 LEX / REX mode setting
Miscellaneous settings
Device label, Control lock status
Display brightness, Jog dial rotary direction, Fan setting
User EDID data (U1-U12), Emulated EDIDs by ports

13.6.15. F130 - Transceiver Mode

General
Operation mode setting, Application mode selection setting
Device label
Crosspoint settings
Video stream switch state, Audio stream switch state
HDMI input port
Video port name, HDCP setting
Stream settings
Enable/disable status, Color space conversion setting
Scaler settings
Enable/disable status, Resolution setting, Image position
Color space conversion setting, color range setting, color depth setting
HDMI output ports
Port name, HDCP mode, Power +5V mode, Color depth setting
No sync screen mode, No sync screen color
Analog audio input port
Port name, Volume, Balance, Gain settings
Analog audio output port
Port name, Mute state, Volume, Balance, Gain settings
Ethernet ports
Enable/disable status, Mode setting
Static IP address, Network mask, Gateway address
DHCP status (enable / disable)
RS-232 port
Port name, Command injection status, Command injection port nr.
Baud rate, Data bits, Parity, Stop bits
USB KVM settings
Port names, Enable/disable status
USB HID Local/Remote mode setting, USB 2.0 LEX / REX mode setting
Miscellaneous settings
Device label, Control lock status
Display brightness, Jog dial rotary direction, Fan setting
User EDID data (U1-U12), Emulated EDIDs by ports

13.6.16. F130 - Multiviewer Mode

General
Operation mode setting, Application mode selection setting
Device label
Crosspoint settings
Video stream switch state, Audio stream switch state
Stream settings
Enable/disable status, Color space conversion setting
Scaler settings
Enable/disable status, Resolution setting, Image position
Color space conversion setting, color range setting
Multiviewer settings
Tile enable/disable status, Canvas resolution setting, Tile size, Tile position, Tile opacity
Color depth setting
HDMI output ports
Port name, HDCP mode, Power +5V mode, Color depth setting
No sync screen mode, No sync screen color
Analog audio input port
Port name, Volume, Balance, Gain settings
Analog audio output port
Port name, Mute state, Volume, Balance, Gain settings
Ethernet ports
Enable/disable status, Mode setting
Static IP address, Network mask, Gateway address
DHCP status (enable / disable)
RS-232 port
Port name, Command injection status, Command injection port nr.
Baud rate, Data bits, Parity, Stop bits
USB KVM settings
Port names, Enable/disable status
USB HID Local/Remote mode setting, USB 2.0 LEX / REX mode setting
Miscellaneous settings
Device label, Control lock status
Display brightness, Jog dial rotary direction, Fan setting
User EDID data (U1-U12), Emulated EDIDs by ports

13.7. Release Notes of the Firmware Packages

13.7.1. Release Notes

v3.5.5b8

Release date: 2026-02-09

New feature:

- The new firmware introduces enhanced protection mechanisms to detect faults in certain protocol converter cables (DP/miniDP/USB-C to HDMI) and safeguard the UBEX from their potential effects. For optimal performance, we recommend using Lightware-manufactured USB-C to HDMI cables, as the device has been validated to operate reliably with them. When third-party cables are used, certain video input changes such as resolution or audio sampling rate adjustments may cause the cable's audio transmission to fail, resulting in distorted sound and significant fluctuations in CTS/N values. To mitigate these issues, the firmware automatically mutes the embedded audio upon fault detection to protect the UBEX. In addition, two independent optional controls are available via the LW3 API. One setting enables the device to issue an automatic HPD signal to attempt recovery of the cable from the faulty state (enabled by default). A separate setting allows the UBEX endpoint to automatically reboot if it becomes unreachable on the network due to such an error (disabled by default). These features can be used independently or together, depending on system requirements. For further assistance, please contact Support.

v3.5.2b1

Release date: 2025-01-21

New feature:

- A clock tick-overflow issue has been fixed, which previously required a workaround that caused the product to restart every 49 days. The product is now back to full 24/7 operation.

v3.5.1b1

Release date: 2024-10-01

New feature:

- Fix the update script in the last package.

v3.5.0b4

Release date: 2024-08-26

New feature:

- Support F111 and F121 variants.

v3.4.0b7

Release date: 2024-06-17

New feature:

- The new firmware supports the new F130 hardware and USB 2.0 extension. Known limitations: - missing LDC support for multiview mode and multistream in transmitter mode - USB 2.0 connection requires LARA or an external controller; USB 2.0 switching is not yet supported by the LW3 API

v3.3.1b1

Release date: 2023-10-06

Bugfix:

- Fixed the numbers of supported streams in Multiviewer mode

v3.3.0b4

Release date: 2023-09-11

New feature:

- Multistream is supported in transmitter mode. It could transmit 4 streams instead of 2 streams. Both HDMI input can be transmitted as scaled and native mode in same time.

v3.2.0b9

Release date: 2023-08-30

New feature:

- A new operating mode (multiview) has been added to the endpoint firmware without MMU and LDC support for now. Currently it can be only configured by LW3 commands according to the user manual.
- Added new scaling options ("Tile resolution") in TX and TRX mode for proper multiview operation.

v3.1.1b3

Release date: 2023-07-19

New feature:

- Forced output color depth option is added for the perfect seamless switching. UBEX supports limiting the color depth also on the link to reduce the bandwidth.
- The UBEX endpoint supports deep color and HDR contents (e.g. Dolby Vision). The new version (v3.1.1) isn't compatible with previous versions (v2.x.y).

v3.0.2b3

Release date: 2023-07-19

New feature:

- The minimum speed of the fans has been set to 2500 RPM.
- Firmware update is improved and flash memory is extended. The functionality is the same as v2.4.1. It is a compatibility package because of the downgrading from v3.x.y to v2.x.y is not possible.

v3.0.0b2

Release date: 2023-03-16

New feature:

- The UBEX endpoint supports deep color and HDR contents (e.g. Dolby Vision). The new version (v3.0.0) isn't compatible with previous versions (v2.x.y).

v2.4.1b13

Release date: 2022-09-13

New feature:

- We fixed some known issue in the firmware of the portprocessor, like random black screen on the output after rebooting.
- Added the scaler function for the second video pipe in transmitter mode.

Bugfix:

- We fixed the random initialization issue of video pipe at some resolutions (e.g. 2912x2184p60).

v2.3.3b10

Release date: 2022-07-25

New feature:

- Incompatibility issue with newer version of AVI info frame is fixed. AVI info frame version 4 is converted to version 2.

v2.3.2b4

Release date: 2022-06-16

New feature:

- Fixed the RJ45 converter module test issue of the EOLT (production).

Bugfix:

- Some resolutions (e.g. 2080x2184p60) didn't work properly, so we improved our bandwidth calculation algorithm and fixed this issue.

v2.3.1b1

Release date: 2022-02-11

Bugfix:

- Fixed an End-of-Line Test (EOLT) reboot issue.

v2.3.0b1

Release date: 2022-02-09

New feature:

- USB KM (HID devices such as keyboard, mouse) extension added to the firmware. Only the F120 hardware version and currently only the emulated transmission mode are supported.
- Support for the "SFP+ to RJ45" converter module has been added to the firmware. In this case, the minimum fan speed is 2500 rpm.

v2.1.0b3

Release date: 2021-09-01

New feature:

- The scaling module was also added to the second video pipe in receiver mode. Both outputs of UBEX receivers are scalable.
- The scaling module was also added to the input video pipe in transceiver mode. Both input and output of UBEX transceivers are scalable.

v2.0.0b6

Release date: 2021-06-18

New feature:

- Added HBR audio support
- Replaced HDMI IP core and driver
- Fixed sync polarity handling

Bugfix:

- Fixed glitches with Channel Status display in audio nodes
- Fixed frame detector values for 4:2:0 signals
- Fixed reliability issues with audio signal type detection and pass-through
- Fixed LW3 error with SFP Compatible property when not seated

v1.5.5b3

Release date: 2020-12-17

Bugfix:

- Fixed 4:2:2 10-bit video transmission
- Fixed issues with 2.1 or more audio channels

v1.5.4b1

Release date: 2020-10-07

Bugfix:

- Fixed the video timing and audio bug.

v1.5.3b1

Release date: 2020-09-10

New feature:

- Added 3840x2400p60_reduced timing to scaler

Bugfix:

- Fixed a glitch with static IP settings storage
- Fixed the inconsistency of factory default network settings on RX devices
- Fixed a regression in EOL testing

v1.5.2b1

Release date: 2020-08-12

Bugfix:

- Fixed a compatibility issue with older LDU2 releases
- Fixed reliability problems with the HTTP server component
- Fixed an issue with pre-v1.4.0 migration support
- Fixed flash storage support that caused boot loops on some devices

v1.5.1b1

Release date: 2020-05-26

Bugfix:

- Fixed a bug with IR reception

v1.5.0b8

Release date: 2020-05-11

New feature:

- Source locked mode is now supported.
- Scaling and frame rate conversion are also supported on transmitter side.
- The frame rate converter and scaler modules support image cropping in case of downscaling in center image position.
- 12-bit deep color HDMI signals can be transmitted in 10 bit mode.
- Extended Identify Me feature to RJ45 ports
- Added support for cropper on secondary video pipe
- Added Compatible property to SFP nodes
- Added home screen to LCD menu
- Added local input loopback and copy features to RX mode
- Added support for automatic video freeze on signal loss as a NoSync option
- Added copy feature to TRX mode
- Added support for manual video freeze
- Added support for Dark Mode
- Updated video processing latency calculations (fixes tearing and flickering issues in some setups)
- Added processing latency property to video pipes
- Added support for altering Color Range
- Added overall Health Status properties

Bugfix:

- SCDC registers are only modified, if the connected display supports this protocol.
- 4k60 resolution was not transmitted to displays, which were 4k60 capable, but did not report SCDC capability in EDID, such as LG27UD58. Fixed.
- Fixed video tearing when converting between 60 and 24 Hz
- Fixed a glitch with EDID caching
- Fixed a glitch with HDMI outputs after operation mode change (TX/RX/TRX)
- Fixed a glitch with TMDS clocks between 310 and 340 MHz (e.g. 3440x1440p60)
- Fixed artifacts with video wall at 4K60
- Fixed HDMI audio node 'Connected' state
- Improved support for newer SFP+ standards (OM3/OM4 and copper lengths)
- Fixed a glitch that could cause an additional delay of one frame

v1.4.2b4

Release date: 2020-01-30

New feature:

- Added option to force HDCP 2.2 Type 1 Content on outputs

Bugfix:

- Fixed glitches with settings storage and factory defaults restoration
- Improved support for updating devices that are already in service mode

v1.4.1b2

Release date: 2019-12-03

Bugfix:

- Fixed a glitch with input scaler configuration storage
- Optimized runtime memory usage

v1.4.0b4

Release date: 2019-11-27

New feature:

- Added check to refuse downgrading to earlier versions

Bugfix:

- Added file system in order to cope with bad NAND flash blocks
- Improved stability for multicast update

v1.3.2b2

Release date: 2019-08-14

New feature:

- Fixed issues with using the 10.0.0.0/8 IP range for control

v1.3.1b5

Release date: 2019-07-02

New feature:

- Added support for No Sync Screen generation on TX/TRX sources (for network diagnostics)
- Added support for LDC Orientation Preference setting
- Improved LLDP support (reporting operation mode and package version)
- Added identify() method to S and O nodes
- Fixed channel status data for analog audio inputs
- Refined fan control (silent operation)
- Added support for R100 part numbers
- Added support for IR in F110
- Added support for centralized firmware update

Bugfix:

- Fixed a glitch with some 10G switches not switching streams automatically

Known issue:

- Video output is unstable when scaling a pre-cropped image to 4K@60

v1.3.0b10

Release date: 2019-05-03

New feature:

- Added support for Transceiver mode
- Added support for scaling to the default resolution of the attached display (EDID-based scaling)
- Added support for F110 variant (analog audio in/out, RS-232)
- Added support for upgrading endpoints in matrix mode with LDU2

Bugfix:

- Signal properties are reported on unconnected outputs as well
- All RX/TX mode related settings are cleared when operation mode is changed
- Fixed issues with fan control
- Added support for LW3 configuration backup and restore
- Fixed issue with color space conversion for DVI inputs
- Fixed a glitch with updating dynamic EDIDs
- Improved stability of the embedded bootloader

v1.2.0b1

Release date: 2018-10-05

Bugfix:

- Fixed issue with detecting HDMI 1.x sources after receiving 4K@60 Hz
- Fixed 4K@30 Hz transmission over a single 10G link
- Fixed image artifacts with a few scaling configurations

v1.1.1b1

Release date: 2018-08-30

Bugfix:

- More robust SCDC handling is introduced.

v1.1.0b6

Release date: 2018-06-25

New feature:

- Source locked mode is now supported.
- Scaling and frame rate conversion are also supported on transmitter side.
- The frame rate converter and scaler modules support image cropping in case of downscaling in center image position.
- 12-bit deep color HDMI signals can be transmitted in 10 bit mode.

Bugfix:

- 4K60 4:4:4 and 4K30 4:4:4 signals can be passed through at the same time.
- SCDC registers are only modified, if the connected display supports this protocol.

v1.0.1b4

Release date: 2018-05-14

13.7.2. Known Issues

The firmware package of the UBEX endpoint devices contains a few known issues and limitations which are going to be fixed in a future firmware release.

- 4:2:0 sampling is supported on the input and output ports in pass-through mode only.
- The configuration restore procedure works on the same type of operation modes only.
- When the combined bandwidth of the streams is very close to the bandwidth limit of the network link, partial synchronisation can occur. Reducing the color depth or the frame rate of one stream can solve the issue.
- No GUI support for the Icron USB 2.0 module of the UBEX-PRO20-HDMI-F130 model.

13.8. Resolutions of the Scaler

The following list contains the resolutions and refresh rates that can be forced on the scaler for the sink device.

Resolution	Comment
640 x 480 @ 60 Hz	
720 x 480 @ 60 Hz	
720 x 576 @ 50 Hz	
800 x 600 @ 60 Hz	
848 x 480 @ 60 Hz	
1024 x 768 @ 60 Hz	
1280 x 720 @ 50 Hz	
1280 x 720 @ 60 Hz	
1280 x 768 @ 50 Hz	
1280 x 768 @ 60 Hz	
1280 x 768 @ 75 Hz	
1280 x 800 @ 60 Hz	
1280 x 1024 @ 50 Hz	
1280 x 1024 @ 60 Hz	
1280 x 1024 @ 75 Hz	
1360 x 768 @ 60 Hz	
1366 x 768 @ 60 Hz	
1400 x 1050 @ 50 Hz	
1400 x 1050 @ 60 Hz	
1400 x 1050 @ 75 Hz	
1440 x 900 @ 60 Hz	
1440 x 1080 @ 60 Hz	
1600 x 900 @ 60 Hz	
1600 x 1200 @ 50 Hz	
1600 x 1200 @ 60 Hz	
1920 x 1080 @ 24 Hz	
1920 x 1080 @ 25 Hz	
1920 x 1080 @ 30 Hz	

Resolution	Comment
1920 x 1080 @ 50 Hz	
1920 x 1080 @ 59 Hz	
1920 x 1080 @ 60 Hz	
1920 x 1200 @ 50 Hz	
1920 x 1200 @ 60 Hz	
2048 x 1080 @ 50 Hz	
2048 x 1080 @ 60 Hz	
2048 x 1200 @ 60 Hz	
2080 x 2184 @ 60 Hz	
2560 x 1080 @ 60 Hz	
2560 x 1440 @ 60 Hz	
2560 x 1600 @ 60 Hz	
2560 x 2048 @ 60 Hz	
2912 x 2184 @ 60 Hz	
3440 x 1440 @ 24 Hz	
3440 x 1440 @ 25 Hz	
3440 x 1440 @ 30 Hz	
3840 x 2160 @ 24 Hz	
3840 x 2160 @ 25 Hz	
3840 x 2160 @ 30 Hz	
3840 x 2160 @ 60 Hz	
3840 x 2160 @ 60 Hz	with reduced blanking
3840 x 2400 @ 24 Hz	
3840 x 2400 @ 30 Hz	
3840 x 2400 @ 60 Hz	with reduced blanking
4096 x 2160 @ 24 Hz	
4096 x 2160 @ 25 Hz	
4096 x 2160 @ 30 Hz	
4096 x 2160 @ 50 Hz	
4096 x 2160 @ 60 Hz	

13.9. Factory EDID List

Mem.	Resolution				Type
F1	640 x	480p	@ 60.0	Hz	D
F2	848 x	480p	@ 60.0	Hz	D
F3	800 x	600p	@ 60.32	Hz	D
F4	1024 x	768p	@ 60.0	Hz	D
F5	1280 x	768p	@ 50.0	Hz	D
F6	1280 x	768p	@ 59.94	Hz	D
F7	1280 x	768p	@ 75.0	Hz	D
F8	1360 x	768p	@ 60.02	Hz	D
F9	1280 x	1024p	@ 50.0	Hz	D
F10	1280 x	1024p	@ 60.02	Hz	D
F11	1280 x	1024p	@ 75.02	Hz	D
F12	1400 x	1050p	@ 50.0	Hz	D
F13	1400 x	1050p	@ 60.0	Hz	D
F14	1400 x	1050p	@ 75.0	Hz	D
F15	1680 x	1050p	@ 60.0	Hz	D
F16	1920 x	1080p	@ 50.0	Hz	D
F17	1920 x	1080p	@ 60.0	Hz	D
F18	2048 x	1080p	@ 50.0	Hz	D
F19	2048 x	1080p	@ 60.0	Hz	D
F20	1600 x	1200p	@ 50.0	Hz	D
F21	1600 x	1200p	@ 60.0	Hz	D
F22	1920 x	1200p	@ 50.0	Hz	D
F23	1920 x	1200p	@ 59.56	Hz	D
F24	2048 x	1200p	@ 59.96	Hz	D
F25-F28	Reserved				
F29	1920 x	1080p	@ 60.0	Hz	U
F30-F31	Reserved				
F32	640 x	480p	@ 59.95	Hz	H
F33	720 x	480p	@ 59.94	Hz	H
F34	720 x	576p	@ 50.0	Hz	H

Mem.	Resolution				Type
F35	1280 x	720p	@ 50.0	Hz	H
F36	1280 x	720p	@ 60.0	Hz	H
F37-F40	Reserved				
F41	1920 x	1080p	@ 24.0	Hz	H
F42	1920 x	1080p	@ 25.0	Hz	H
F43	1920 x	1080p	@ 30.0	Hz	H
F44	1920 x	1080p	@ 50.0	Hz	H
F45	1920 x	1080p	@ 59.94	Hz	H
F46	1920 x	1080p	@ 60.0	Hz	H
F47	1920 x	1080p	@ 60.0	Hz	U
F48	1920 x	1080p	@ 60.0	Hz	U
F49	1920 x	1080p	@ 60.0	Hz	U
F50-F89	Reserved				
F90	1920 x	2160p	@ 59.99	Hz	D
F91	1024 x	2400p	@ 60.01	Hz	D
F92	1920 x	2400p	@ 59.97	Hz	D
F93	2048 x	2400p	@ 59.98	Hz	D
F94	2048 x	1536p	@ 60.0	Hz	D
F95	2048 x	1536p	@ 75.0	Hz	D
F96	2560 x	1600p	@ 59.86	Hz	D
F97	3840 x	2400p	@ 24.0	Hz	D
F98	1280 x	720p	@ 60.0	Hz	H3D
F99	1920 x	1080p	@ 60.0	Hz	H3D
F100	1024 x	768p	@ 60.0	Hz	H
F101	1280 x	1024p	@ 50.0	Hz	H
F102	1280 x	1024p	@ 60.02	Hz	H
F103	1280 x	1024p	@ 75.02	Hz	H
F104	1600 x	1200p	@ 50.0	Hz	H
F105	1600 x	1200p	@ 60.0	Hz	H
F106	1920 x	1200p	@ 59.56	Hz	H

Mem.	Resolution				Type
F107	2560 x	1440p	@ 59.95	Hz	H
F108	2560 x	1600p	@ 59.86	Hz	H
F109	3840 x	2400p	@ 24.0	Hz	H
F110	3840 x	2160p	@ 24.0	Hz	H
F111	3840 x	2160p	@ 25.0	Hz	H
F112	3840 x	2160p	@ 30.0	Hz	H
F113-F117	Reserved				
F118	3840 x	2160p	@ 30.0	Hz	U
F119	3840 x	2160p	@ 30.0	Hz	U
F120	3840 x	2160p	@ 60.0	Hz	H
F121	1440 x	1080p	@ 59.91	Hz	H
F122	2560 x	2048p	@ 59.98	Hz	H
F123	1280 x	800p	@ 59.91	Hz	H
F124	1440 x	900p	@ 59.9	Hz	H
F125	1366 x	768p	@ 60.0	Hz	H
F126	1600 x	900p	@ 59.98	Hz	H
F127	2048 x	1080p	@ 60.0	Hz	H
F128	2560 x	1080p	@ 60.0	Hz	H
F129	3440 x	1440p	@ 24.99	Hz	H
F130	3440 x	1440p	@ 29.99	Hz	H
F131	4096 x	2160p	@ 25.0	Hz	H
F132	4096 x	2160p	@ 30.0	Hz	H
F133	4096 x	2160p	@ 60.0	Hz	H
F134	3440 x	1440p	@ 23.99	Hz	H
F135	4096 x	2160p	@ 24.0	Hz	H
F136	3840 x	2400p	@ 29.99	Hz	H
F137	3840 x	2160p	@ 60.0	Hz	H
F138	3840 x	2160p	@ 50.0	Hz	H
F139	3840 x	2160p	@ 60.0	Hz	H
F140	3840 x	2160p	@ 60.0	Hz	H

Mem.	Resolution				Type
F141	4096 x	2160p	@ 60.0	Hz	H
F142	4096 x	2160p	@ 50.0	Hz	H
F143	4096 x	2160p	@ 60.0	Hz	H
F144	4096 x	2160p	@ 60.0	Hz	H
F145	Reserved				
F146	3840 x	2160p	@ 60.0	Hz	H
F147	3840 x	2160p	@ 60.0	Hz	H
F148	3840 x	2160p	@ 60.0	Hz	H

Legend

D: DVI EDID

H: HDMI EDID

U: Universal EDID, supporting many standard resolutions:

- **F29:** Universal EDID for DVI signals (no audio support).
- **F47:** HDMI EDID supporting PCM audio.
- **F48:** HDMI EDID supporting all type of audio.
- **F49:** HDMI EDID supporting all type of audio and deep color.
- **F118:** HDMI EDID supporting PCM audio and 4K@30 Hz signals.
- **F119:** HDMI EDID supporting all type of audio and 4K@30 Hz signals.

Please note that minor changes in the factory EDID list may be applied in further firmware versions.

13.10. Mechanical Drawings

13.10.1. UBEX F-series Endpoint Devices

The following drawings present the physical dimensions of the UBEX F-series endpoints. Dimensions are in mm.

Affected models:

- UBEX-PRO20-HDMI-F100
- UBEX-PRO20-HDMI-F110
- UBEX-PRO20-HDMI-F111
- UBEX-PRO20-HDMI-F120
- UBEX-PRO20-HDMI-F121
- UBEX-PRO20-HDMI-F130

Front View

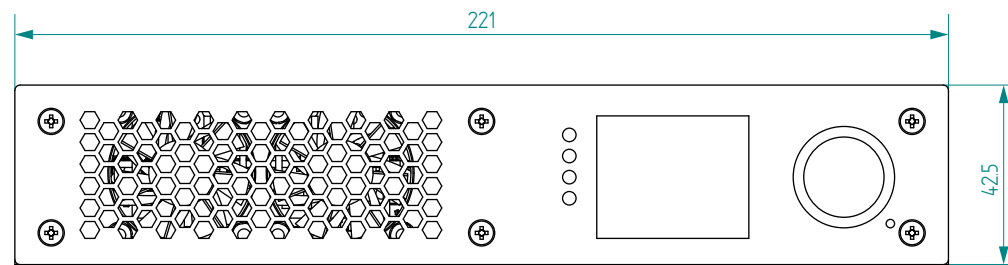

Side View

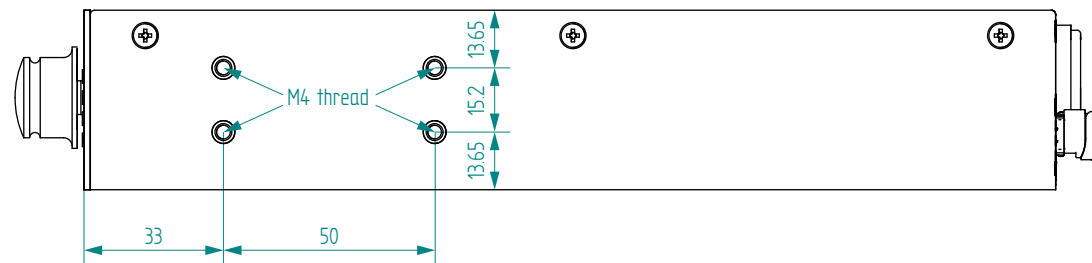

Bottom View

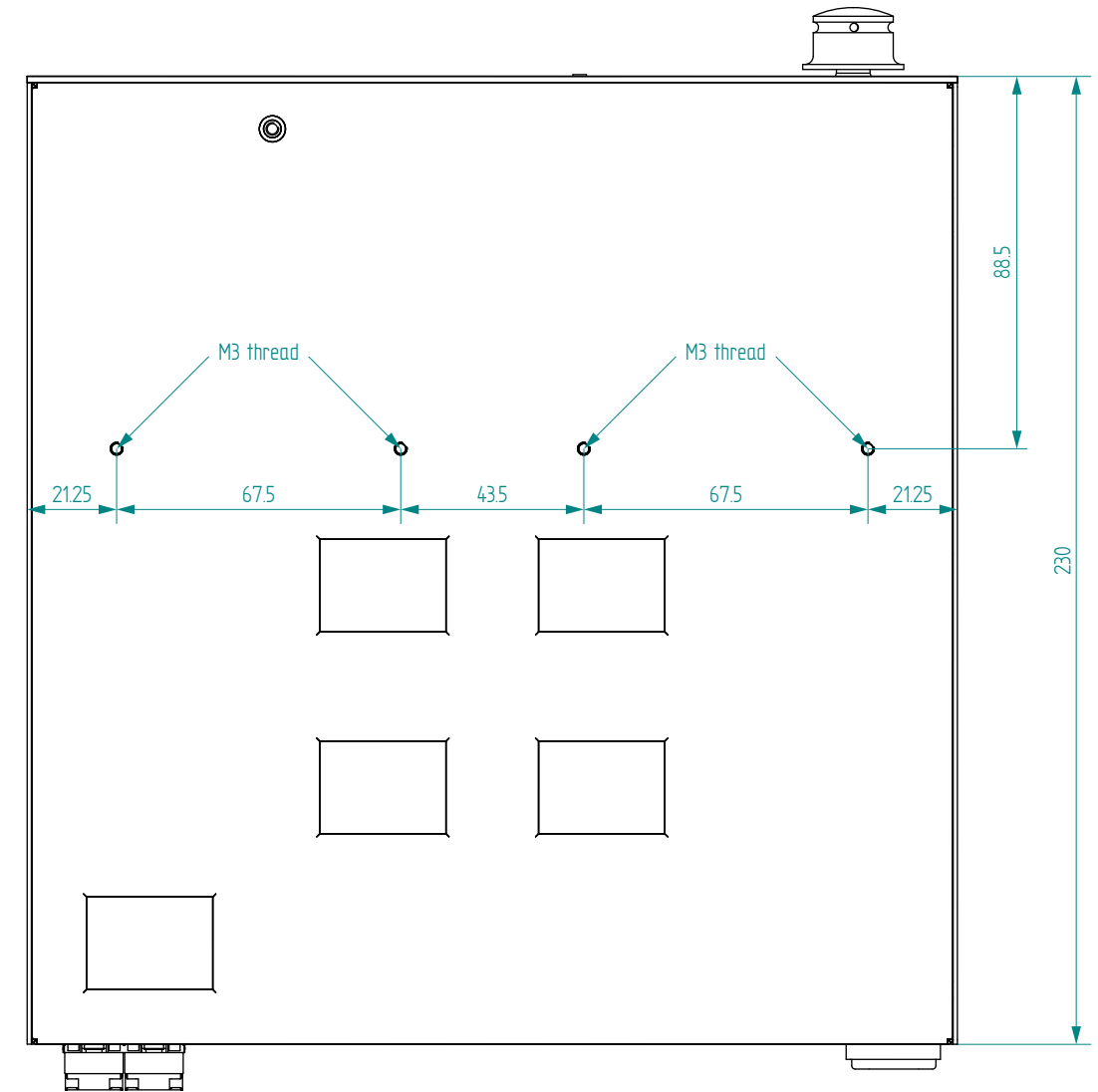

13.10.2. UBEX R-series Endpoint Devices

The following drawings present the physical dimensions of the UBEX R-series endpoints. Dimensions are in mm.

Affected models:

- UBEX-PRO20-HDMI-R100 2xMM-2xDUO
- UBEX-PRO20-HDMI-R100 2xMM-QUAD
- UBEX-PRO20-HDMI-R100 2xSM-2xDUO
- UBEX-PRO20-HDMI-R100 2xSM-QUAD
- UBEX-PRO20-HDMI-R100 2xSM-BiDi-DUO

Front View

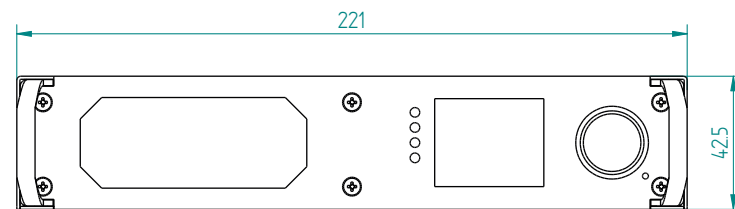

Side View

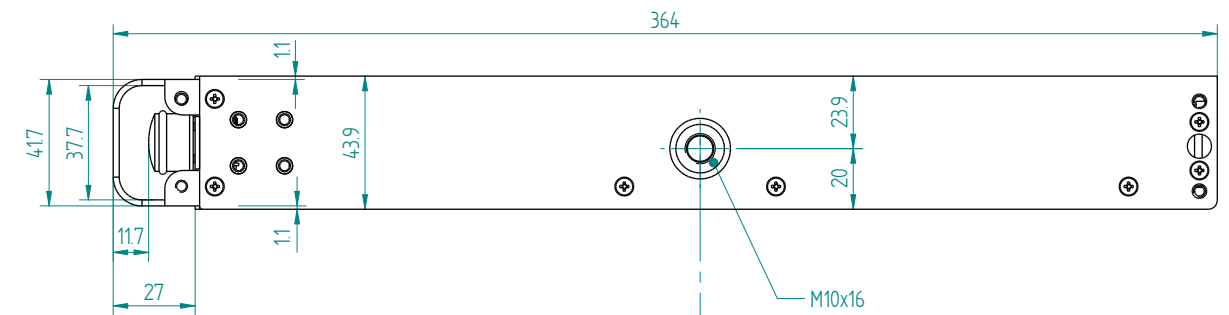

Top View

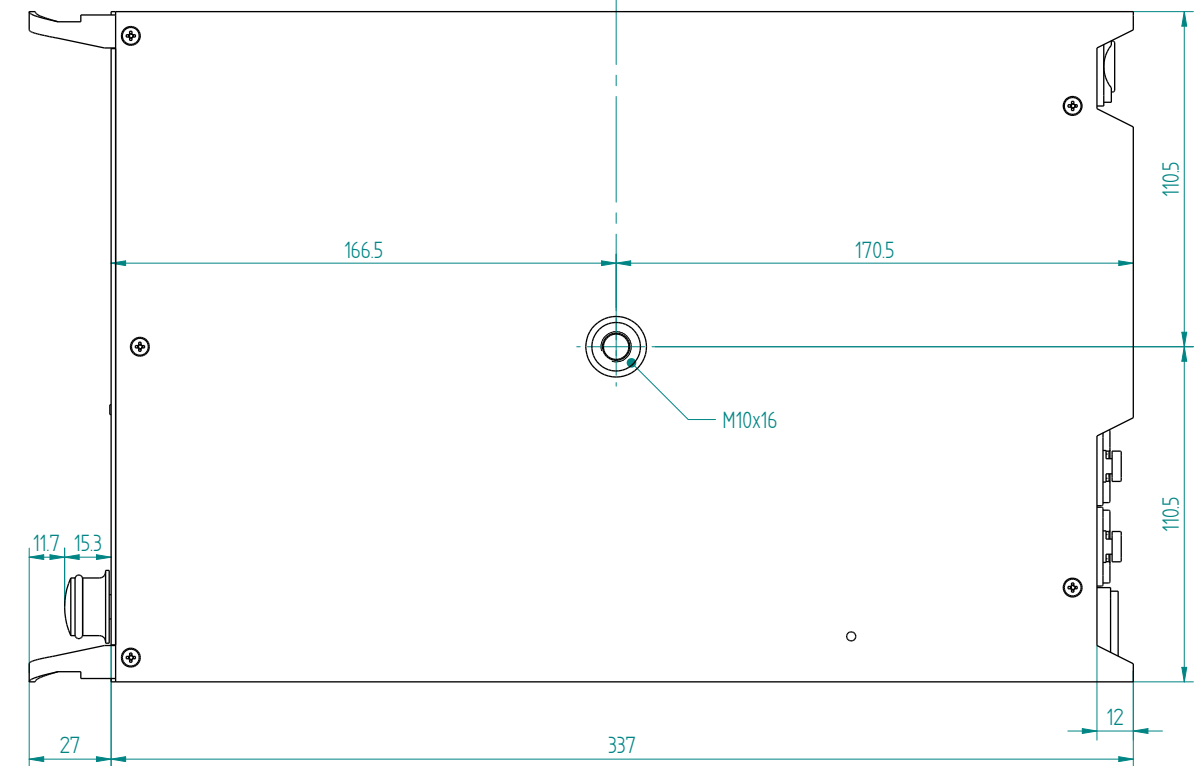

13.11. Bandwidth Requirements of the Resolutions

13.11.1. Calculation Formula

The required bandwidth of a resolution can be calculated by a simple formula. Using the formula, the user can get the bandwidth requirement of any resolution. *#bandwidth*

$$[\text{Horizontal pixels}] \times [\text{Vertical pixels}] \times [\text{Refresh rate}] \times [\text{Color depth}] \times [\text{Color sampling multiplier}] \times 1.08 = \{\text{Bandwidth}\}$$

The 1.08 multiplier is the overhead, which includes the data that is transmitted together with the AV signal.

Color Sampling Multiplier

The final result depends on the applied color sampling. In case of 4:4:4, the bandwidth is the same, so the multiplier will be 1. In case of 4:2:2 color sampling, the number will be the 66% of it; in case of 4:2:0, it is halved.

Color sampling	Color sampling multiplier
4:4:4	1
4:2:2	0.66
4:2:0	0.5

Let's see an example. Here is an one of the most used resolution: 4K UHD 60Hz 4:4:4 8bit/ch

The formula: $3840 \times 2160 \times 60 \times 24 \times 1 \times 1.08 = 12,899,450,880 \approx 12.9 \text{ Gbps}$

ATTENTION: In case of F130 endpoint model the USB KVM transmission **always reserves 2 Gbps bandwidth** so the the available total bandwidth is **8 Gbps** in case of 1x10G SFP+ connection and **18 Gbps** in case of 2x10G SFP+ connection.

Examples

The following examples show how it can be applied to it in the real life.

Resolution	Horizontal pixels	Vertical pixels	Refresh rate	Color depth	Color sampling multiplier	Overhead multiplier	Result	Bandwidth
1280x720@60Hz 4:4:4 10bit/ch	1280	720	60	30	1	1.08	1,791,590,400	1.79 Gbps
1600x1200@50Hz 4:4:4 8bit/ch	1600	1200	50	24	1	1.08	2,488,320,000	2.49 Gbps
1920x1080@60Hz 4:2:2 12bit/ch	1920	1080	60	36	0.66	1.08	3,192,614,093	3.19 Gbps
1920x1080@60Hz 4:4:4 8bit/ch	1920	1080	60	24	1	1.08	3,224,862,720	3.23 Gbps
2560x2048@60Hz 4:4:4 8bit/ch	2560	2048	60	24	1	1.08	8,153,726,976	8.15 Gbps
3840x2160@30Hz 4:4:4 12bit/ch	3840	2160	30	36	1	1.08	9,674,588,160	9.67 Gbps
4096x2160@30Hz 4:2:0 12bit/ch	4096	2160	30	36	0.5	1.08	5,159,780,352	5.16 Gbps
4096x2160@30Hz 4:4:4 12bit/ch	4096	2160	30	36	1	1.08	10,319,560,704	10.32 Gbps
3840x2160@60Hz 4:4:4 8bit/ch	3840	2160	60	24	1	1.08	12,899,450,880	12.9 Gbps
4096x2160@60Hz 4:4:4 8bit/ch	4096	2160	60	24	1	1.08	13,759,414,272	13.76 Gbps

13.11.2. Table of the Most Used Resolutions

F and R series Endpoint Models

DIFFERENCE: This table refers to the UBEX-PRO20-HDMI-F100, -F110, -F111, -F120, -F121 and R100 series endpoint models only. The F130 model operates with different bandwidth limitations, see the dedicated table of this model in the [F130 Endpoint Model](#) section (next page).

The following table contains the bandwidth requirement when transmitting one or two AV signals together. The table is grouped by resolution, color space, and color depth. The values are in Gb/s.

			Stream 1														
			No signal	1920x1080p60 (1080p)				3840x2160p30 (4K UHD 30)				3840x2160p60 (4K UHD 60)					
				YCbCr 4:2:2	RGB / YCbCr 4:4:4			YCbCr 4:2:2	RGB / YCbCr 4:4:4			YCbCr 4:2:0	YCbCr 4:2:2			RGB / YCbCr 4:4:4	
				12 bit/ch	8 bit/ch	10 bit/ch	12 bit/ch	12 bit/ch	8 bit/ch	10 bit/ch	12 bit/ch	12 bit/ch	8 bit/ch	10 bit/ch	12 bit/ch	8 bit/ch	
Stream 2	No signal		N/A	3.23	3.23	4.03	4.84	6.45	6.45	8.06	9.68	9.68	8.63	10.75	12.90	12.90	
	1920x1080 60 Hz (1080p)	YCbCr 4:2:2	12 bit/ch	3.23	6.45	6.45	7.26	8.06	9.68	9.68	11.29	12.90	12.90	11.86	13.98	16.13	16.13
		RGB / YCbCr 4:4:4	8 bit/ch	3.23	6.45	6.45	7.26	8.06	9.68	9.68	11.29	12.90	12.90	11.86	13.98	16.13	16.13
			10 bit/ch	4.03	7.26	7.26	8.06	8.87	10.48	10.48	12.10	13.71	13.71	12.66	14.78	16.93	16.93
			12 bit/ch	4.84	8.06	8.06	8.87	9.68	11.29	11.29	12.90	14.51	14.51	13.47	15.59	17.74	17.74
	3840x2160 30 Hz (4K UHD 30)	YCbCr 4:2:2	12 bit/ch	6.45	9.68	9.68	10.48	11.29	12.90	12.90	14.51	16.13	16.13	15.08	17.20	19.35	19.35
		RGB / YCbCr 4:4:4	8 bit/ch	6.45	9.68	9.68	10.48	11.29	12.90	12.90	14.51	16.13	16.13	15.08	17.20	19.35	19.35
			10 bit/ch	8.06	11.29	11.29	12.10	12.90	14.51	14.51	16.13	17.74	17.74	16.69	18.81	20.97	20.97
			12 bit/ch	9.68	12.90	12.90	13.71	14.51	16.13	16.13	17.74	19.35	19.35	18.31	20.43	22.58	22.58
	3840x2160 60 Hz (4K UHD 60)	YCbCr 4:2:0	12 bit/ch	9.68	12.90	12.90	13.71	14.51	16.13	16.13	17.74	19.35	19.35	18.31	20.43	22.58	22.58
		YCbCr 4:2:2	8 bit/ch	8.63	11.86	11.86	12.66	13.47	15.08	15.08	16.69	18.31	18.31	17.26	19.38	21.53	21.53
			10 bit/ch	10.75	13.98	13.98	14.78	15.59	17.20	17.20	18.81	20.43	20.43	19.38	21.50	23.65	23.65
			12 bit/ch	12.90	16.13	16.13	16.93	17.74	19.35	19.35	20.97	22.58	22.58	21.53	23.65	25.80	25.80
		RGB / YCbCr 4:4:4	8 bit/ch	12.90	16.13	16.13	16.93	17.74	19.35	19.35	20.97	22.58	22.58	21.53	23.65	25.80	25.80

Legend: < 10 Gbps 1 pc SFP+ module is enough for the transmission. < 20 Gbps 2 pcs SFP+ modules are required for the transmission.
> 20 Gbps The transmission is not possible with 2 pcs SFP+ modules.

F130 Endpoint Model

DIFFERENCE: This table refers to the UBEX-PRO20-HDMI-F130 endpoint model only.

ATTENTION: In case of **F130** endpoint model the USB KVM and the USB 2.0 transmission reserves **2 Gbps bandwidth** also in LEX and REX modes, so the available total bandwidth is **8 Gbps** in case of 1x10G SFP+ connection and **18 Gbps** in case of 2x10G SFP+ connection. In case of **disabled mode**, this restriction is ceased and the available bandwidth is up to 20 Gbps.

The following table contains the bandwidth requirement when transmitting one or two AV signals together. The table is grouped by resolution, color space, and color depth. The values are in Gb/s.

				Stream 1													
				No signal	1920x1080p60 (1080p)				3840x2160p30 (4K UHD 30)				3840x2160p60 (4K UHD 60)				
					YCbCr 4:2:2	RGB / YCbCr 4:4:4			YCbCr 4:2:2	RGB / YCbCr 4:4:4			YCbCr 4:2:0	YCbCr 4:2:2			RGB / YCbCr 4:4:4
	12 bit/ch	8 bit/ch	10 bit/ch	12 bit/ch	12 bit/ch	8 bit/ch	10 bit/ch	12 bit/ch	12 bit/ch	8 bit/ch	10 bit/ch	12 bit/ch	8 bit/ch				
Stream 2	No signal			N/A	3.23	3.23	4.03	4.84	6.45	6.45	8.06	9.68	9.68	8.63	10.75	12.90	12.90
	1920x1080 60 Hz (1080p)	YCbCr 4:2:2	12 bit/ch	3.23	6.45	6.45	7.26	8.06	9.68	9.68	11.29	12.90	12.90	11.86	13.98	16.13	16.13
		RGB / YCbCr 4:4:4	8 bit/ch	3.23	6.45	6.45	7.26	8.06	9.68	9.68	11.29	12.90	12.90	11.86	13.98	16.13	16.13
			10 bit/ch	4.03	7.26	7.26	8.06	8.87	10.48	10.48	12.10	13.71	13.71	12.66	14.78	16.93	16.93
			12 bit/ch	4.84	8.06	8.06	8.87	9.68	11.29	11.29	12.90	14.51	14.51	13.47	15.59	17.74	17.74
	3840x2160 30 Hz (4K UHD 30)	YCbCr 4:2:2	12 bit/ch	6.45	9.68	9.68	10.48	11.29	12.90	12.90	14.51	16.13	16.13	15.08	17.20	19.35	19.35
		RGB / YCbCr 4:4:4	8 bit/ch	6.45	9.68	9.68	10.48	11.29	12.90	12.90	14.51	16.13	16.13	15.08	17.20	19.35	19.35
			10 bit/ch	8.06	11.29	11.29	12.10	12.90	14.51	14.51	16.13	17.74	17.74	16.69	18.81	20.97	20.97
			12 bit/ch	9.68	12.90	12.90	13.71	14.51	16.13	16.13	17.74	19.35	19.35	18.31	20.43	22.58	22.58
	3840x2160 60 Hz (4K UHD 60)	YCbCr 4:2:0	12 bit/ch	9.68	12.90	12.90	13.71	14.51	16.13	16.13	17.74	19.35	19.35	18.31	20.43	22.58	22.58
		YCbCr 4:2:2	8 bit/ch	8.63	11.86	11.86	12.66	13.47	15.08	15.08	16.69	18.31	18.31	17.26	19.38	21.53	21.53
			10 bit/ch	10.75	13.98	13.98	14.78	15.59	17.20	17.20	18.81	20.43	20.43	19.38	21.50	23.65	23.65
12 bit/ch			12.90	16.13	16.13	16.93	17.74	19.35	19.35	20.97	22.58	22.58	21.53	23.65	25.80	25.80	
RGB / YCbCr 4:4:4		8 bit/ch	12.90	16.13	16.13	16.93	17.74	19.35	19.35	20.97	22.58	22.58	21.53	23.65	25.80	25.80	

Legend: < 8 Gbps 1 pc SFP+ module is enough for the transmission.

< 18 Gbps 2 pcs SFP+ modules are required for the transmission.

> 18 Gbps The transmission is not possible with 2 pcs SFP+ modules.

13.12. Cable Wiring Guide

Inputs and outputs of audio devices are symmetric or asymmetric. The main advantage of the symmetric lines is the better protection against the noise, therefore they are widely used in the professional audio industry. Symmetric audio is most often referred to as balanced audio, as opposed to asymmetric, which is referred to as unbalanced audio. Lighthouse products are usually built with 5-pole Phoenix connectors, so we would like to help users assemble their own audio cables. See the most common cases below.

- Symmetric and asymmetric lines can be **linked with passive accessories** (e.g. special cables), but in this case half of the line level is lost.
- There are numerous types of regularly used connector and cable types to connect audio devices. Please always make sure that a **connector or cable fits your system** before use.
- Never join the **phase-inverted** (negative, cold or -) poles (either right or left) to the ground or to each other on the output side, as this can damage the unit.
- Use a **galvanic isolation** in case of a ground loop.

13.12.1. Serial Ports

The device is built with a 3-pole Phoenix connector. See the examples below of connecting to a DCE (Data Circuit-terminating Equipment) or a DTE (Data Terminal Equipment) type device:

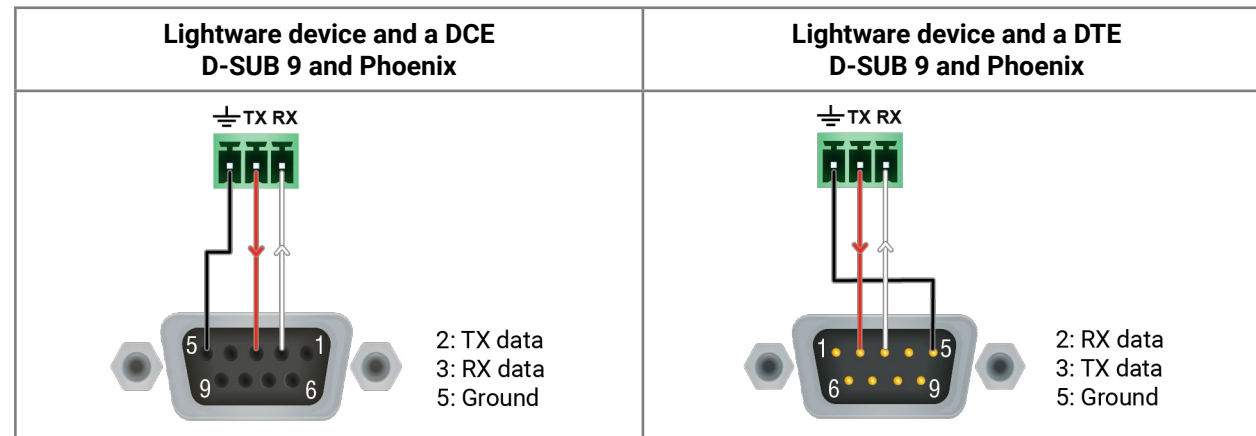

13.12.2. Audio Ports

The Pinout of the 5-pole Phoenix Connector



Pin nr.	Signal
1	Left+
2	Left-
3	Ground
4	Right-
5	Right+

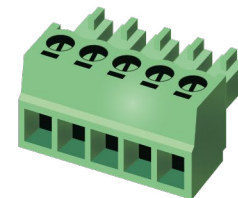

Compatible Plug Type: Phoenix® Combicon series (3.5mm pitch, 5-pole), type: MC 1.5/5-ST-3.5.

From Unbalanced Output to Balanced Input

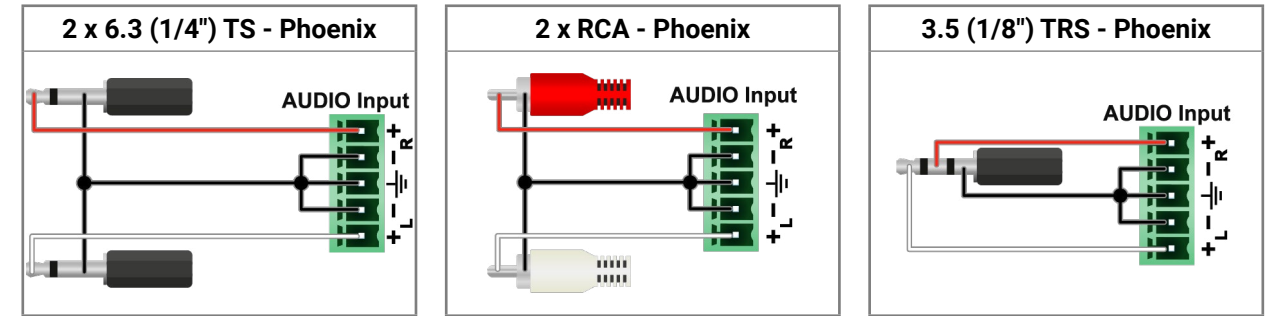

From Balanced Output to Unbalanced Input

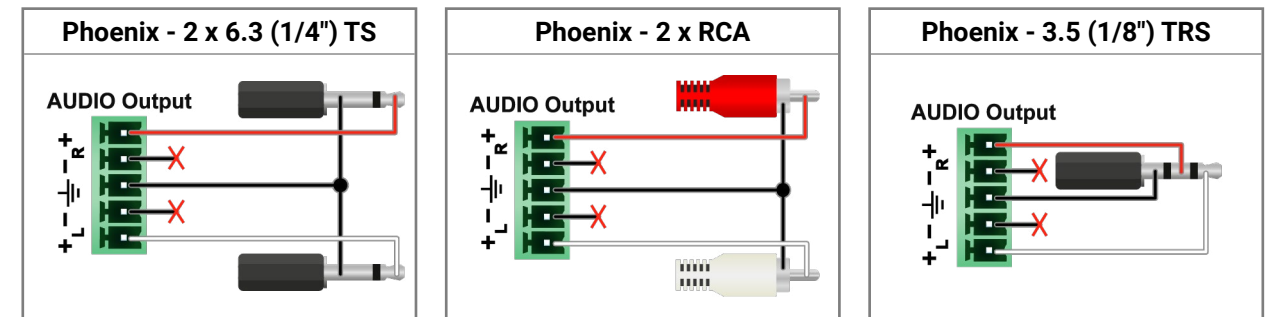

From Balanced Output to Balanced Input

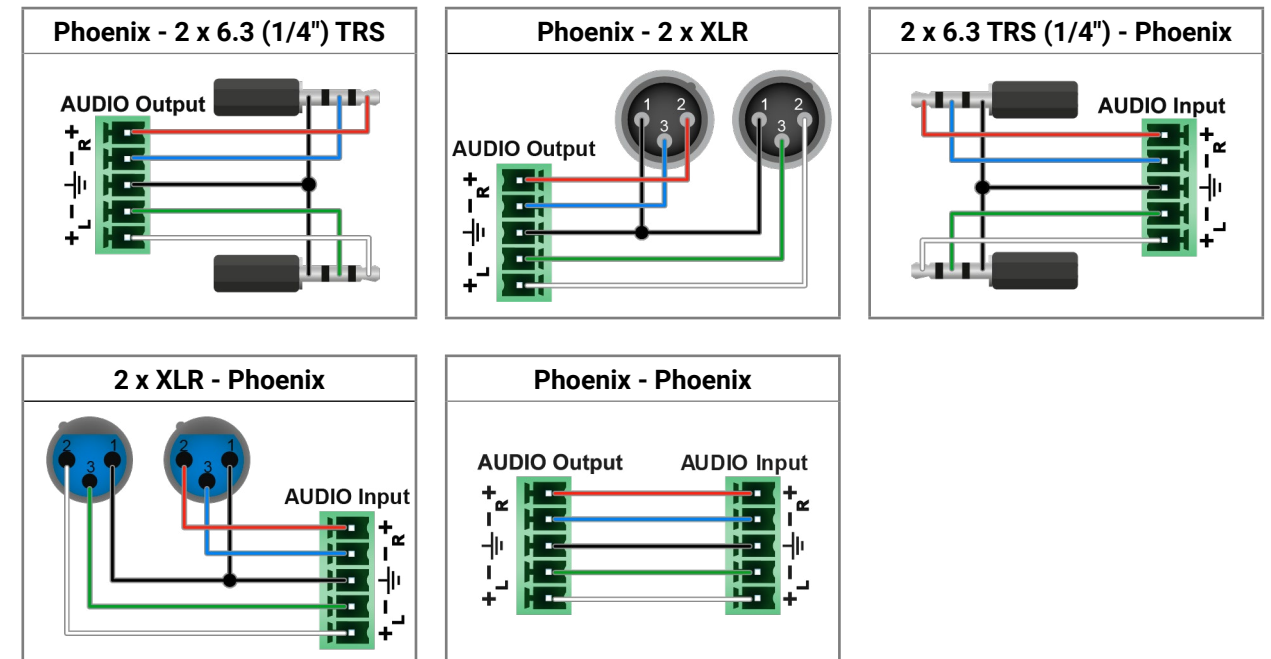

13.13. Quick Link Collection

What do you want to do? The following link collection helps to find the related section for your current activity. The collection is grouped by **topic category** and within that is in **alphabetical order**.

Activity	Front panel	LDC software	LW3 command
General			
Application mode change	-	-	7.4.12
Backup/restore	-	6.12	-
Bootload mode setting	3.11.7	-	7.4.16
Control lock	-	6.11.3	7.4.15
Custom text on the LCD screen	-	-	7.4.4
Dark mode setting	3.11.4	6.11.3	7.4.7
Device label change	-	6.11.1	7.4.1
Factory default restore	3.11.5	6.11.4	7.4.18
Firmware version query	3.9	6.11.1	7.4.3
Identify the device	-	6.11.1	7.4.6
Jog dial control knob - rotary direction	3.11.4	-	7.4.13
LCD screen brightness	3.11.4	-	7.4.14
Log file export	-	6.11.4	-
Operation mode (TX/RX/TRX) change	3.11.2	6.11.1	7.4.12
Operation mode (TX/RX/TRX) query	3.2.2	6.11.1	7.4.11
Restarting the device	3.11.6	6.11.4	7.4.17
Video (TX)			
Color depth setting (inputs)	-	6.5.3	7.5.14
Color range setting (inputs)	-	6.5.3	7.5.13
CSC setting (inputs)	3.4.1	6.5.3	7.5.12
HDCP setting (inputs)	3.4.1	6.5.1	7.5.16
HDCP setting (local outputs)	3.4.3	6.5.2	7.5.17
Identify stream	-	6.5.11	7.5.7
Port status query (inputs)	3.2	6.5.1	7.5.1
Port status query (local outputs)	3.2	6.5.2	7.5.2
Scaler - Image position	3.4.1	6.5.3	7.5.10
Scaler - Forced resolution	3.4.1	6.5.3	7.5.8
Scaler - Scaling mode	3.4.1	6.5.3	7.5.9

Activity	Front panel	LDC software	LW3 command
Stream enable/disable	3.4.1	6.5.4	7.5.6
Stream status query	3.4.1	6.5.4	7.5.1
Tile resolution for multiviewer	-	-	7.5.11
Video (RX)			
Color depth setting (outputs)	-	6.5.6	7.6.14
Color range setting (outputs)	-	6.5.6	7.6.13
Crosspoint change	3.4.2	6.4	7.6.4
Crosspoint state query	3.4.2	6.4	7.6.3
CSC setting (outputs)	3.5.2	6.5.6	7.6.12
Freeze the signal (outputs)	-	6.5.6	7.6.17
HDCP setting (outputs)	3.5.2	6.5.7	7.6.22
HDCP setting (local inputs)	3.5.3	6.5.7	7.6.21
Identify display	-	6.5.11	7.6.23
Port status query (outputs)	3.2	6.5.7	7.6.2
Port status query (local inputs)	3.2	6.5.7	7.6.1
Scaler - Image position	3.5.2	6.5.6	7.6.11
Scaler - Forced resolution	3.5.2	6.5.6	7.6.10
Scaler - Scaling mode	3.5.2	6.5.6	7.6.8
Source MUX settings	3.5.2	6.5.10	7.6.25
Stream enable/disable	3.5.2	6.5.4	7.6.7
Stream status query	3.5.2	6.5.7	7.6.1
Timing mode setting	-	6.5.7	7.6.16
Unfreeze the signal	-	6.5.6	7.6.18
Video (TRX)			
Color depth setting (input)	-	6.5.3	7.7.15
Color range setting (output)	-	6.5.6	7.7.15
Color range setting (input)	-	6.5.4	7.7.14
Color range setting (output)	-	6.5.6	7.7.14
CSC setting (input)	3.6.1	6.5.4	7.7.13
CSC setting (output)	3.6.2	6.5.6	7.7.13
Freeze the signal (output)	-	6.5.6	7.7.18
HDCP setting (input)	3.6.1	6.5.1	7.7.22
HDCP setting (local output)	3.6.5	6.5.2	7.7.23

Activity	Front panel	LDC software	LW3 command
HDCP setting (output)	3.6.2	6.5.7	7.7.23
Identify display	-	6.5.11	7.7.6
Identify stream	-	6.5.11	7.7.6
Port status query (input)	3.2	6.5.1	7.7.1
Port status query (local output)	3.2	6.5.2	7.7.2
Port status query (output)	3.2	6.5.7	7.7.2
Scaler - Image position	3.6.2	6.5.6	7.7.11
Scaler - Forced resolution	3.6.2	6.5.6	7.7.10
Scaler - Scaling mode	3.6.2	6.5.6	7.7.8
Source MUX settings	3.6.5	6.5.10	7.7.25
Stream enable/disable (input)	3.6.1	6.5.4	7.7.5
Stream enable/disable (output)	3.6.2	6.5.4	7.7.5
Stream status query (input)	3.6.1	6.5.4	7.7.1
Stream status query (local output)	3.6.5	6.5.2	7.7.2
Stream status query (output)	3.6.2	6.5.7	7.7.2
Tile resolution for multiviewer	-	-	7.7.12
Timing mode setting	-	6.5.7	7.7.17
Unfreeze the signal (output)	-	6.5.6	7.7.19
Multiviewer (RXMV)			
Canvas resolution	-	-	7.8.1
Color depth setting (outputs)	-	-	7.8.7
HDCP setting (outputs)	-	-	7.8.11
Identify display	-	-	7.8.12
Identify stream	-	-	7.8.12
Layer order	-	-	7.8.5
Source MUX settings	-	-	7.8.13
Tile enable/disable	-	-	7.8.2
Tile opacity	-	-	7.8.6
Tile position	-	-	7.8.3
Tile size (resolution)	-	-	7.8.4
Tile status query	-	-	7.8.8
Audio			
Analog audio balance setting (input)	-	6.7.1	7.10.3

Activity	Front panel	LDC software	LW3 command
Analog audio balance setting (output)	-	6.7.2	7.10.3
Analog audio gain setting	-	6.7.1	7.10.4
Analog audio output status query	-	6.6	7.11.4
Analog audio volume setting in dB (input)	-	6.7.1	7.10.1
Analog audio volume setting in dB (output)	-	6.7.2	7.10.1
Analog audio volume setting in percent (input)	-	6.7.1	7.10.2
Analog audio volume setting in percent (output)	-	6.7.2	7.10.2
Audio stream enable/disable	-	-	7.9.6
Crosspoint change	-	6.7.3	7.9.4
Mute/unmute the analog output	-	6.7.2	7.10.5
Port status query (RX - outputs)	3.2	6.6	7.9.2
Port status query (TRX - inputs)	3.2	6.6	7.9.1
Port status query (TRX - outputs)	3.2	6.6	7.9.2
Port status query (TX - inputs)	3.2	6.6	7.9.1
Port status query (TX - outputs)	3.2	6.6	7.9.2
EDID Management			
Copy / save a user EDID	3.8.3	6.9.1	7.13.5
Create EDID	-	6.9.3	-
Delete a user EDID	-	6.9.1	7.13.6
Edit an EDID	-	6.9.2	-
Reset the emulated EDIDs	-	6.9.1	7.13.7
Switch (emulate)	3.8.2	6.9.1	7.13.4
Query the emulated EDID	3.8.1	6.9	7.13.1
Diagnostics			
Frame detector	-	6.8.1	-
No sync screen (test pattern) color (RX)	-	6.8.2	7.6.20
No sync screen (test pattern) color (RXMV)	-	-	7.8.10
No sync screen (test pattern) color (TRX)	3.6.2	6.8.2	7.7.21
No sync screen (test pattern) mode (RX)	-	6.8.2	7.6.19
No sync screen (test pattern) mode (RXMV)	-	-	7.8.9
No sync screen (test pattern) mode (TRX)	3.6.2	6.8.2	7.7.20
RS-232 Interface			
RS-232 port configuration	-	6.10.2	7.15

Activity	Front panel	LDC software	LW3 command
Sending ASCII-format text	-	-	7.17.1
Sending ASCII-format message	-	6.10.2	7.17.3
Sending binary message	-	-	7.17.2
Infrared Interface			
Change command injection port number	-	6.10.3	7.16.3
Enable command injection	-	6.10.3	7.16.2
Enable output signal modulation	-	-	7.16.4
Enable the port	-	6.10.3	7.16.1
Sending pronto hex message in big-endian format	-	-	7.17.5
Sending pronto hex message in little-endian format	-	6.10.3	7.17.4
USB K+M Interface (F120 / F121 models)			
Enable USB-A Emulated (D1/D2) port power	3.10.2	-	7.18.11
Enable USB-A Emulated (D1/D2) suspend	3.10.2	-	7.18.12
Enable USB-B Receiver (U1) upstream	3.10.1	-	7.18.4
Local control mode setting	-	6.10.4	7.18.2
Query emulated device info	3.10.2	6.10.4	7.18
Query receiver device state	3.10.1	6.10.4	7.18
Remote control mode setting	-	6.10.4	7.18.1
USB KVM and USB 2.0 Interface (F130 model)			
Enable USB HID Emulated (D1/D2) port power	3.10.2	-	7.19.14
Enable USB HID Emulated (D1/D2) suspend	3.10.2	-	7.19.15
Enable USB HID Receiver (U1) upstream	3.10.1	-	7.19.7
Query emulated USB HID device info	3.10.2	6.10.4	7.19
Query receiver USB HID device state	3.10.1	6.10.4	7.19
Query the IP address of the Icron module	-	-	7.19.3
Query the MAC address of the Icron module	-	-	7.19.2
Remote (REX) / Local (LEX) operation mode setting	-	-	7.19.1
Remote/local control mode setting	-	6.10.4	7.19.4
Local control mode setting	-	6.10.4	7.19.5
Network			
DHCP (dynamic IP address) setting	3.11.1	6.11.2	7.14.2
Gateway address change (static)	3.11.1	6.11.2	7.14.9
IP address query	3.11.1	6.11.2	7.14.4

Activity	Front panel	LDC software	LW3 command
IP address setting (static)	3.11.1	6.11.2	7.14.5
Subnet mask change (static)	3.11.1	6.11.2	7.14.7
SFP+ Interface			
Bandwidth limitation indicator query	-	6.5.5	7.11.8
Bandwidth query	3.9	6.5.9	7.11.7
General status query	3.9	6.5.9	-
Link aggregation status query	3.9	6.5.12	7.11.9
SFP+ module information query	3.9	6.5.9	7.12

13.14. Hashtag Keyword List

This user manual contains keywords with hashtags (#) to help you find the relevant information as quick as possible.

The format of the keywords is the following:

#<keyword>

The usage of the keywords: use the **Search** function (Ctrl+F / Cmd+F) of your PDF reader application, type the # (hashtag) character and the wished keyword.

The **#new** special keyword indicates a new feature/function that has just appeared in the latest firmware or software version.

Example

#dhcp

This keyword is placed at the DHCP (dynamic IP address) setting in the front panel operation, the Lightware Device Controller (LDC) and the LW3 programmer's reference section.

The following list contains all hashtag keywords placed in the document with a short description belonging to them. The list is in **alphabetical order** by the hashtag keywords.

Hashtag Keyword ↓	Description
#advancedview	Advanced view window
#analogaudio	Analog audio related settings
#applicationmode	Application mode (extender/matrix) setting
#audio	Audio related settings
#backup	Configuration cloning (backup)
#balance	Balance (for analog audio) setting
#bandwidth	Calculation of the bandwidth requirement information
#bootload	Bootload mode setting
#canvas	Canvas related settings in Multiviewer mode
#colordepth	Color depth setting
#colorrange	Color range setting
#colorspace	Color space converter related settings
#configurationcloning	Configuration cloning (backup)
#controllock	Control lock
#crosspoint	Crosspoint switch setting
#csc	Color space converter related settings
#darkmode	Dark mode setting

Hashtag Keyword ↓	Description
#devicelabel	Device label
#dhcp	Dynamic IP address (DHCP) setting
#disconnect	Disconnecting stream setting (crosspoint)
#edid	EDID related settings
#ethernet	Ethernet port settings
#extendermode	Application mode (extender/matrix) setting
#factory	Factory default settings
#firmwareversion	Firmware version query
#framedetector	Frame detector in LDC
#frc	Frame rate converter related settings
#freerun	Timing mode setting
#freeze	Signal freeze
#gain	Gain (for analog audio) setting
#hdcp	HDCP-encryption related setting
#icron	USB KVM related settings (F130 variant)
#identifydisplay	Identify display feature
#identifyme	Identify me (identify the device) feature
#identifystream	Identify stream feature
#infra	Infrared port related settings
#ipaddress	IP address related settings
#ir	Infrared port related settings
#jogdial	Jog dial control knob related settings
#km	USB K+M related settings (F120 / F121 variant)
#kvm	USB KVM related settings (F130 variant)
#label	Device label
#log	System log
#mac	MAC address query
#matrixmode	Application mode (extender/matrix) setting
#message	Message sending via communication ports
#multiviewer	Multiviewer related settings
#mute	Mute (for analog audio) setting

Hashtag Keyword ↓	Description
#mux	Source multiplexer (MUX) related settings
#network	Network (IP address) related settings
#new	New feature/function of the product
#nosyncscreen	Test pattern (no sync screen) settings
#operationmode	Operation mode (TX/RX/TRX/RXMV) setting
#portstatus	Source/destination port status query
#power5v	Power 5V mode setting
#reboot	Restarting the device
#receiver	Receiver (RX) operation mode setting
#reset	Restarting the device
#restart	Restarting the device
#rotary	Jog dial control knob related settings
#rs232	RS-232 related settings
#rs-232	RS-232 related settings
#rx	Receiver (RX) operation mode setting
#rxmv	Multiviewer (RXMV) operation mode setting
#scaler	Scaler related settings
#seamless	Settings for seamless switching
#serial	RS-232 related settings
#sfp	SFP+ module monitoring information
#sourcelocked	Timing mode setting
#sourcemux	Source multiplexer (MUX) related settings
#status	Status query
#streamenable	Stream enable/disable setting
#switch	Crosspoint switch setting
#terminal	Advanced view window
#testpattern	Test pattern (no sync screen) settings
#tile	Tile related settings in Multiviewer mode
#timingmode	Timing mode setting
#transceiver	Transceiver (TRX) operation mode setting
#transmitter	Transmitter (TX) operation mode setting

Hashtag Keyword ↓	Description
#trx	Transceiver (TRX) operation mode setting
#tx	Transmitter (TX) operation mode setting
#unmute	Unmute (for analog audio) setting
#usbkm	USB K+M related settings (F120 / F121 variant)
#usbkvm	USB KVM related settings (F130 variant)
#volume	Volume (for analog audio) setting

13.15. Further Document Information

Symbol Legend

The following symbols and markings are used in the document:





- **WARNING! Safety-related information that is highly recommended to read and keep in every case!**
- **ATTENTION:** Useful information for performing a successful procedure; it is recommended to read.
- **DIFFERENCE:** Feature or function that is available with a specific firmware/hardware version or product variant.
- **INFO:** A notice, which contains additional information. Procedure can be successful without reading it.
- **DEFINITION:** The short description of a feature or a function.
- **TIPS AND TRICKS:** Ideas that you may have not known yet, but can be useful.

Navigation Buttons

Buttons in the PDF version

	Navigate to the Table of Contents .
	Go back to the previous page . If you clicked on a link previously, you can go back to the source page by pressing the button.
	Navigate to the Bookmark page .
	Visit www.lightware.com .

Buttons in the HTML version

	Open the main Table of Contents .
	Navigate to the Online User Manuals webpage.
	Navigate to the Bookmark page in this User Manual.
	Download the PDF version of the User Manual.

About Printing

Lightware Visual Engineering supports green technologies and eco-friendly mentality. Thus, this document is made primarily for digital usage. If you need to print out a few pages for any reason, follow the recommended printing settings:

- Page size: A4
- Output size: Fit to page or Match page size
- Orientation: Landscape

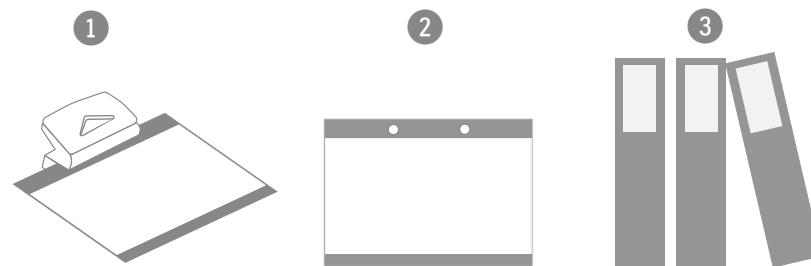

TIPS AND TRICKS: Thanks to the size of the original page, a border around the content (gray on the second picture below) makes it possible to organize the pages better. After punching holes in the printed pages, they can easily be placed into a ring folder.

13.16. Limited Warranty Statement

1. Lightware Visual Engineering PLC (Lightware) warrants to all trade and end user customers that any Lightware product purchased will be free from manufacturing defects in both material and workmanship for three (3) years from purchase unless stated otherwise below. The warranty period will begin on the latest possible date where proof of purchase/delivery can be provided by the customer. In the event that no proof can be provided (empty 'Date of purchase' field or a copy of invoice), the warranty period will begin from the point of delivery from Lightware.

1.1. 25G and MODEX product series will be subject to a seven (7) year warranty period under the same terms as outlined in this document.

1.2. If during the first three (3) months of purchase, the customer is unhappy with any aspect of a Lightware product, Lightware will accept a return for full credit.

1.3. Any product that fails in the first six (6) months of the warranty period will automatically be eligible for replacement and advanced replacement where available. Any replacements provided will be warranted for the remainder of the original unit's warranty period.

1.4. Product failures from six (6) months to the end of the warranty period will either be repaired or replaced at the discretion of Lightware. If Lightware chooses to replace the product, then the replacement will be warranted for the remainder of the original unit's warranty period.

2. The above-stated warranty and procedures will not apply to any product that has been:

2.1. Modified, repaired or altered by anyone other than a certified Lightware engineer unless expressly agreed beforehand.

2.2. Used in any application other than that for which it was intended.

2.3. Subjected to any mechanical or electrical abuse or accidental damage.

2.4. Any costs incurred for repair/replacement of goods that fall into the categories above (2.1., 2.2., 2.3.) will be borne by the customer at a pre-agreed figure.

3. All products to be returned to Lightware require a return material authorization number (RMA) prior to shipment, and this number must be clearly marked on the box. If an RMA number is not obtained or is not clearly marked on the box, Lightware will refuse the shipment.

3.1. The customer will be responsible for in-bound, and Lightware will be responsible for out-bound shipping costs.

3.2. Newly repaired or replaced products will be warranted to the end of the originally purchased product's warranty period.