



USER MANUAL



MX2M-FR24R

Hybrid Modular Multimedia Matrix

Bookmark Page



Important Safety Instructions

Class I apparatus construction.

This equipment must be used with a mains power system with a protective earth connection. The third (earth) pin is a safety feature, do not bypass or disable it. The equipment should be operated only from the power source indicated on the product.

To disconnect the equipment safely from power, remove the power cord from the rear of the equipment or from the power source. The MAINS plug is used as the disconnect device, the disconnect device shall remain readily operable.

There are no user-serviceable parts inside of the unit. Removal of the cover will expose dangerous voltages. To avoid personal injury, do not remove the cover. Do not operate the unit without the cover installed.

The appliance must be safely connected to multimedia systems. Follow instructions described in this manual.

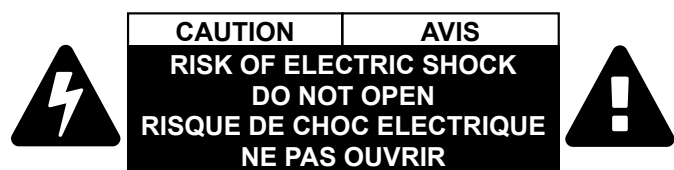

Ventilation

For the correct ventilation and to avoid overheating, ensure enough free space around the appliance. Do not cover the appliance, leave the ventilation holes free and never block or bypass the ventilators (if there are any).

WARNING

To prevent injury, the apparatus is recommended to be securely attach to the floor/wall, or mounted in accordance with the installation instructions. The apparatus shall not be exposed to dripping or splashing, and no objects filled with liquids, such as vases, shall be placed on the apparatus. No naked flame sources, such as lit candles, should be placed on the apparatus.

Replacing the AC fuse (if any)

Unplug the AC power cord from the device. Locate the AC fuse on the rear panel. Replace only the AC fuse as indicated on the rear panel. Connect the power cord to the switcher and to the AC power source. Make sure the switcher is working properly.

Waste Electrical & Electronic Equipment (WEEE)

This marking shown on the product or its literature indicates that it should not be disposed with other household wastes at the end of its working life. To prevent possible harm to the environment or human health from uncontrolled waste disposal, please separate this from other types of wastes and recycle it responsibly to promote the sustainable reuse of material resources. Household users should contact either the retailer where they purchased this product or their local government office for details of where and how they can take this item for environmentally safe recycling. Business users should contact their supplier and check the terms and conditions of the purchase contract. This product should not be mixed with other commercial wastes for disposal.



Caution: Laser product



Common Safety Symbols

Symbol	Description
	Direct current
	Alternating current
	Protective conductor terminal
	Equipotential Connector
	On (Power)
	Off (Power)
	Double insulation
	Caution, possibility of electric shock
	Caution
	Laser radiation
	Warning, Rotating fan
	Caution: for indoor use only

Table of Contents

1. INTRODUCTION	8	3.2.2. System Settings Menu	29	5.5.2. Firmware Update Mode.....	49
1.1. DESCRIPTION	9	3.2.3. Input Ports Menu	29	5.5.3. User Ethernet Mode.....	49
1.2. MODEL COMPARISON	9	3.2.4. Output Ports Menu	30	5.6. LICENSING	49
1.3. BOX CONTENTS	10	3.2.5. EDID Menu	30	5.7. FURTHER BUILT-IN FEATURES	50
1.4. FEATURES	11	3.2.6. Preset Menu.....	31	5.7.1. Device Cloning – Configuration Backup and Restore	50
1.5. TYPICAL APPLICATIONS	14	3.2.7. Health Menu	31	5.7.2. Advanced EDID Management.....	50
1.5.1. Live Event Application	14	4. INSTALLATION	32	5.8. SOFTWARE CONTROL MODES	50
1.5.2. TV Studio Application	15	4.1. MOUNTING OPTIONS	33	6. SOFTWARE CONTROL - BUILT-IN WEBSITE	51
2. PRODUCT OVERVIEW	16	4.2. BOARD INSTALLATION AND HANDLING	34	6.1. ESTABLISHING THE CONNECTION	52
2.1. MATRIX FRAME - FRONT VIEW	17	4.2.1. The Layout of the Input/Output Board Slots.....	34	6.2. THE LAYOUT OF THE BUILT-IN WEB	52
2.2. MATRIX FRAME - REAR VIEW	18	4.2.2. Installation of an I/O Board.....	35	7. SOFTWARE CONTROL - LIGHTWARE DEVICE CONTROLLER	53
2.3. AUXILIARY (AUX) BOARDS.....	19	4.3. POWER DRAWER INSTALLATION	35	7.1. INSTALL AND UPDATE	54
2.3.1. MX2M-AUX-DANTE-32CH.....	19	4.4. ELECTRICAL CONNECTIONS	36	7.2. RUNNING THE LDC	54
2.3.2. MX2M-AUX-8AUDIO	19	4.4.1. AC Power Connection	36	7.3. ESTABLISHING CONNECTION	54
2.4. INPUT (IB) BOARDS.....	19	4.4.2. USB Mini-B Connector	36	7.4. CROSSPOINT MENU	56
2.4.1. MX2M-4HDMI20-IB	19	4.4.3. Ethernet Connectors	36	7.4.1. Video Layer	56
2.4.2. MX2M-4OPTJ-IB	19	4.4.4. RS-232 Connector	37	7.4.2. Audio Layer	57
2.4.3. MX2M-4TPX-IB	20	4.4.5. Symmetrical Analog Stereo Audio Connector.....	37	7.4.3. Legend of the Port Tiles.....	57
2.4.4. MX2M-DH-4DP12-IB.....	20	4.4.6. HDMI Connector	37	7.5. VIDEO PORT PROPERTIES WINDOWS	59
2.5. OUTPUT (OB) BOARDS	21	4.4.7. DisplayPort Connector	37	7.5.1. HDMI / OPTJ Input Port Properties	59
2.5.1. MX2M-4HDMI20-OB.....	21	4.4.8. SC Fiber Optical Connector.....	37	7.5.2. DisplayPort Input Port Properties	59
2.5.2. MX2M-4OPTJ-OB.....	21	4.5. ANALOG AUDIO PORT CONFIGURATION	37	7.5.3. TPX Input Port Properties	60
2.5.3. MX2M-4TPX-OB.....	21	4.6. CONNECTING STEPS	38	7.5.4. HDMI / OPTJ Output Port Properties	60
2.6. POWER DRAWERS	22	4.7. POWERING ON	39	7.5.5. TPX Output Port Properties	61
2.6.1. MX2M-PSU-500-F	22	5. HYBRID MODULAR MATRIX CONCEPT	40	7.5.6. Frame Detector.....	61
2.6.2. MX2M-PSU-1250-FP	22	5.1. VIDEO LAYER	41	7.5.7. CEC Controller	62
2.7. FRONT PANEL LEDs OF THE BOARDS	22	5.1.1. Port Diagram.....	41	7.6. AUDIO PORT PROPERTIES WINDOWS	63
2.7.1. Status LEDs	22	5.1.2. Video Signal Transmission - Example	42	7.6.1. Digital Audio Input Port Properties	63
2.7.2. Status LEDs of the SC Connectors.....	23	5.2. AUDIO LAYER	43	7.6.2. Digital Audio Output Port Properties.....	63
2.7.3. Dante Connector LEDs	23	5.2.1. Overview.....	43	7.6.3. Analog Audio Input Port Properties	64
2.7.4. Analog Audio Input/Output Indicator LEDs	23	5.2.2. Digital Audio Interface	43	7.6.4. Analog Audio Output Port Properties	64
2.7.5. Status LEDs of the TPX Connectors.....	23	5.2.3. Analog Audio Interface	43	7.6.5. Dante® Audio Input Port Properties.....	65
3. FRONT PANEL CONTROL	24	5.2.4. Dante® Audio Interface.....	44	7.6.6. Dante® Audio Output Port Properties.....	65
3.1. FRONT PANEL BUTTON OPERATIONS	25	5.2.5. Multichannel Routing to the Outputs	45	7.7. PRESETS	66
3.1.1. Take / Autotake Mode.....	25	5.2.6. Audio Signal Transmission - Example.....	46	7.8. EDID MANAGEMENT MENU	67
3.1.2. View Crosspoint State.....	25	5.3. CONSUMER ELECTRONICS CONTROL (CEC) INTERFACE	47	7.8.1. EDID Operations	67
3.1.3. Switching Operations	25	5.4. SIGNAL EXTENSION METHODS	47	7.8.2. Editing an EDID	68
3.1.4. Preset Operations.....	26	5.4.1. Audio Signal Extension over Dante Interface	48	7.8.3. Creating an EDID - Easy EDID Creator	68
3.1.5. Output Lock	27	5.4.2. AV Signal Extension over Fiber Optical Cable	48	7.8.4. EDID Summary Window	69
3.1.6. Control Lock.....	28	5.4.3. AV Signal Extension over SDVoE Interface	49	7.8.5. DisplayID Extension.....	69
3.2. FRONT PANEL LCD MENU OPERATIONS	28	5.5. ETHERNET LAYER	49	7.9. SETTINGS MENU	70
3.2.1. Introduction.....	28	5.5.1. Control Mode	49	7.9.1. Overview.....	70

7.9.2. Network.....	70	8.5.5. Querying the List of Failed I/O Boards	83	8.9.7. Restarting Link Training	90
7.9.3. System Log	71	8.5.6. Querying the Product Name of the I/O Board.....	83	8.9.8. Setting the Hot Plug Detect (HPD)	90
7.9.4. System	71	8.5.7. Querying the Serial Number of the I/O Board	83	8.9.9. Setting the HDCP	90
7.10. TERMINAL WINDOW	72	8.5.8. Querying the Firmware Version of the I/O Board	83	8.10. VIDEO SOURCE PORT SETTINGS - TPX	91
7.11. HEALTH MENU.....	72	8.5.9. Rebooting the I/O Board	83	8.10.1. Setting the HDCP.....	91
7.11.1. Overview	72	8.6. VIDEO SWITCHING AND CROSSPOINT SETTINGS	83	8.10.2. Setting the Hot Plug Detect (HPD).....	91
7.11.2. Frame	73	8.6.1. Querying the Video Crosspoint State	83	8.10.3. PoE (Power over Ethernet) Setting.....	91
7.11.3. Aux Slots	73	8.6.2. Switching an Input to an Output	84	8.11. VIDEO DESTINATION PORT SETTINGS - HDMI / OPTJ / TPX	91
7.11.4. Input Slots.....	74	8.6.3. Disconnecting the Output from any Input.....	84	8.11.1. Setting the Color Space Conversion	91
7.11.5. Output Slots.....	74	8.6.4. Switching an Input to All Outputs.....	84	8.11.2. Setting the Signal Type	92
7.11.6. PSU Drawer Slots	75	8.6.5. Multiple Switching.....	84	8.11.3. Setting the Power 5V	92
7.11.7. Failing Devices.....	75	8.6.6. Muting a Video Input.....	84	8.11.4. Setting the HDCP Mode	92
8. LW3 PROGRAMMERS' REFERENCE	76	8.6.7. Unmuting a Video Input	84	8.11.5. Setting the Audio Source	92
8.1. OVERVIEW.....	77	8.6.8. Locking a Video Input.....	85	8.11.6. PoE (Power over Ethernet) Setting.....	93
8.2. INSTRUCTIONS FOR THE TERMINAL APPLICATION USAGE.....	77	8.6.9. Unlocking a Video Input	85	8.12. ANALOG AUDIO PORT PROPERTIES	93
8.3. PROTOCOL RULES.....	77	8.6.10. Muting a Video Output	85	8.12.1. Querying the Input Ports of the Board	93
8.3.1. LW3 Tree Structure and Command Structure (examples).....	77	8.6.11. Unmuting a Video Output	85	8.12.2. Querying the Output Ports of the Board	94
8.3.2. General Rules.....	77	8.6.12. Locking a Video Output.....	85	8.12.3. Setting the Volume in dB	94
8.3.3. Command Types	78	8.6.13. Unlocking a Video Output	85	8.12.4. Setting the Volume in dB by Steps.....	94
8.3.4. Prefix Summary	78	8.7. AUDIO SWITCHING AND CROSSPOINT SETTINGS.....	85	8.12.5. Setting the Volume in Percent.....	94
8.3.5. Error Messages	78	8.7.1. Querying the Audio Crosspoint State	85	8.12.6. Setting the Volume in Percent by Steps.....	94
8.3.6. Escaping	78	8.7.2. Switching an Input to an Output.....	86	8.12.7. Setting the Balance	95
8.3.7. Signature.....	79	8.7.3. Disconnecting the Output from any Input.....	86	8.12.8. Setting the Balance by Steps.....	95
8.3.8. Subscription.....	79	8.7.4. Switching an Input to All Outputs.....	86	8.12.9. Setting the Gain.....	95
8.3.9. Notifications about the Changes of the Properties	79	8.7.5. Multiple Switching.....	86	8.13. DANTE® AUDIO SETTINGS	95
8.3.10. Legend for the Control Commands.....	79	8.7.6. Channel Mapping	86	8.13.1. Renaming the Channel Label.....	95
8.4. SYSTEM COMMANDS.....	80	8.7.7. Muting an Audio Input.....	87	8.13.2. Querying the Sample Rate	95
8.4.1. Querying the Product Name	80	8.7.8. Unmuting an Audio Input	87	8.14. SYSTEM MONITORING COMMANDS.....	96
8.4.2. Setting the Device Label	80	8.7.9. Locking an Audio Input	87	8.14.1. Querying Connected Device Presence.....	96
8.4.3. Querying the Serial Number.....	80	8.7.10. Unlocking an Audio Input.....	87	8.14.2. Querying Video Signal Presence on a Port.....	96
8.4.4. Querying the Firmware Version	80	8.7.11. Muting an Audio Output.....	87	8.14.3. Querying the Signal Type	96
8.4.5. Querying the Date and Time of the System.....	80	8.7.12. Unmuting an Audio Output	87	8.14.4. Querying the Resolution of the Stream.....	96
8.4.6. Setting the Date and Time Manually	80	8.7.13. Locking an Audio Output	87	8.14.5. Querying the Total Size of the Stream	96
8.4.7. Setting the Brightness of the LCD Screen.....	81	8.7.14. Unlocking an Audio Output	87	8.14.6. Querying Embedded Audio Presence	97
8.4.8. Control Lock of the LCD Menu.....	81	8.8. VIDEO SOURCE PORT SETTINGS - HDMI / OPTJ	88	8.14.7. Querying the Color Space of the Stream	97
8.4.9. Adding License.....	81	8.8.1. Setting the HDCP.....	88	8.14.8. Querying the Color Range of the Stream	97
8.4.10. Removing License.....	81	8.8.2. Setting the Color Range	88	8.14.9. Querying the Color Depth of the Stream.....	97
8.4.11. Software Resetting the Device	81	8.8.3. Setting the Hot Plug Detect (HPD)	88	8.14.10. Querying the HDCP-encryption Presence.....	98
8.4.12. Rebooting the Device	81	8.9. VIDEO SOURCE PORT SETTINGS - DP.....	88	8.14.11. Querying the HDCP-encryption Level of the Stream.....	98
8.4.13. Restoring the Factory Default Settings.....	81	8.9.1. Setting the Maximum Lane Number	88	8.14.12. Querying the Maximum Supported HDCP-encryption Level	98
8.5. I/O BOARD MANAGEMENT	82	8.9.2. Setting the Maximum Link Data Rate.....	89	8.14.13. Querying the HDCP Error	98
8.5.1. Querying the Status of a Board.....	82	8.9.3. Setting the DP Power	89	8.14.14. Querying the TMDS Error Counters.....	99
8.5.2. Querying the Number of Seated I/O Boards.....	82	8.9.4. Setting the Test Pattern Mode.....	89	8.14.15. Querying the Audio Mismatch Status.....	99
8.5.3. Querying the List of Seated I/O Boards	82	8.9.5. Setting the Color Space Conversion	89	8.15. PRESET HANDLING.....	99
8.5.4. Querying the List of Operational I/O Boards.....	82	8.9.6. Setting the Color Range	90	8.15.1. Creating a New Preset	99
				8.15.2. Saving the Settings to an Existing Preset.....	99

8.15.3. Loading a Preset	99	8.20.2. Press&Release Commands	110	11.3. PIXEL ACCURATE RECLOCKING	136
8.15.4. Renaming a Preset	100	8.20.3. Sending an OSD String	110	12. APPENDIX	137
8.16. EDID MANAGEMENT	100	8.20.4. Sending a CEC Command in Hexadecimal Format.....	110	12.1. SPECIFICATIONS	138
8.16.1. Querying the Emulated EDIDs.....	100	8.21. FIRMWARE UPDATING OF THE I/O BOARDS	111	12.1.1. MX2M-FR24R.....	138
8.16.2. Querying the Validity of a Dynamic EDID	100	8.21.1. Querying the Firmware Version of the I/O Board	111	12.1.2. MX2M-PSU-500-F	138
8.16.3. Querying the Preferred Resolution of a User EDID	100	8.21.2. Launching the Firmware Update Procedure.....	111	12.1.3. MX2M-PSU-1250-FP	139
8.16.4. Emulating an EDID on an Input Port.....	100	8.21.3. Cancelling the Firmware Update Procedure.....	111	12.1.4. MX2M-4HDMI20-IB	139
8.16.5. Copying an EDID to User Memory	101	8.21.4. Querying the Update Progress Status.....	111	12.1.5. MX2M-DH-4DP12-IB.....	140
8.16.6. Deleting an EDID from User Memory	101	8.21.5. Querying the List of Updating Boards.....	112	12.1.6. MX2M-4OPTJ-IB	140
8.16.7. Resetting the Emulated EDIDs.....	101	8.21.6. Querying the Overall Board Update Status	112	12.1.7. MX2M-4TPX-IB	141
8.17. HEALTH STATUS MONITORING COMMANDS	101	8.22. LW3 PROTOCOL COMMANDS - QUICK SUMMARY	113	12.1.8. MX2M-4HDMI20-OB.....	141
8.17.1. Querying the Overall Health State of the Matrix.....	101	9. FIRMWARE UPDATE.....	118	12.1.9. MX2M-4OPTJ-OB	142
8.17.2. Querying the Temperature Warnings	101	9.1. PREPARATION	119	12.1.10. MX2M-4TPX-OB	143
8.17.3. Querying the Temperature Errors	102	9.1.1. About the Firmware Package (LFP2 File)	119	12.1.11. MX2M-AUX-DANTE-32CH.....	143
8.17.4. Querying the Voltage Warnings	102	9.1.2. LDU2 Installation	119	12.1.12. MX2M-AUX-8AUDIO	144
8.17.5. Querying the Voltage Errors.....	102	9.2. RUNNING THE SOFTWARE	120	12.2. SWITCH SETUP FOR DANTE® AUDIO SIGNAL TRANSMISSION.....	145
8.17.6. Querying the Current Warnings	102	9.2.1. LDU2 Interfaces.....	120	12.3. APPLIED PORTS (NETWORK SETTINGS).....	145
8.17.7. Querying the Current Errors	102	9.3. THE UPDATING STEPS	121	12.4. FACTORY DEFAULT SETTINGS.....	146
8.17.8. Querying the Fan Warnings.....	102	9.4. UPDATING VIA GUI	122	12.5. INPUT/OUTPUT PORT NUMBERING	147
8.17.9. Querying the Fan Errors	103	9.5. COMMAND LINE INTERFACE (CLI).....	123	12.5.1. Video Input/Output Port Numbering.....	147
8.17.10. Querying the PSU Drawer Warnings.....	103	9.5.1. How to Run	123	12.5.2. Audio Input Port Numbering.....	147
8.17.11. Querying the PSU Drawer Errors	103	9.5.2. How to Use.....	124	12.5.3. Audio Output Port Numbering.....	148
8.17.12. Querying the Health State of an I/O Board.....	103	9.6. CLI COMMANDS	124	12.6. MAXIMUM CABLE DISTANCES	148
8.17.13. Querying the Health State of a PSU Drawer	104	9.6.1. Help	124	12.6.1. Fiber Optical Cable Distances	148
8.17.14. Querying the Health State of the HSMB	105	9.6.2. LDU2 Version	124	12.6.2. CATx Cable Distances for Dante	148
8.17.15. Querying the Health State of the CECU	106	9.6.3. Checking For New LDU2 Version.....	124	12.6.3. CATx Cable Distances for TPX	148
8.18. NETWORK CONFIGURATION	106	9.6.4. Device Info	125	12.7. FACTORY EDID LIST.....	149
8.18.1. Querying the DHCP State.....	106	9.6.5. Update.....	125	12.8. CABLE WIRING GUIDE	151
8.18.2. Changing the DHCP State.....	106	9.6.6. Restore	126	12.8.1. Audio Ports	151
8.18.3. Querying the IP Address	106	9.6.7. Package Options	126	12.9. MECHANICAL DRAWINGS	152
8.18.4. Changing the IP Address (Static).....	107	9.6.8. Complex Example.....	127	12.9.1. MX2M-FR24R.....	152
8.18.5. Querying the Subnet Mask.....	107	9.6.9. Exit Codes	128	12.9.2. IB/OB Boards.....	153
8.18.6. Changing the Subnet Mask (Static)	107	9.7. IF THE UPDATE IS NOT SUCCESSFUL.....	128	12.9.3. AUX Boards.....	154
8.18.7. Querying the Gateway Address	107	10. TROUBLESHOOTING	129	12.10. RELEASE NOTES OF THE FIRMWARE PACKAGES.....	154
8.18.8. Changing the Gateway Address (Static).....	107	10.1. USE CASES	130	12.11. HASHTAG KEYWORD LIST	157
8.18.9. Applying the Network Settings.....	107	10.2. HOW TO SPEED UP THE TROUBLESHOOTING PROCESS	131	12.12. FURTHER DOCUMENT INFORMATION	159
8.19. RS-232 PORT CONFIGURATION	107	11. TECHNOLOGIES	132	12.13. LIMITED WARRANTY STATEMENT	159
8.19.1. Enabling/Disabling the Port.....	107	11.1. EDID MANAGEMENT	133		
8.19.2. Setting the BAUD Rate	108	11.1.1. Understanding the EDID.....	133		
8.19.3. Setting the Databits.....	108	11.1.2. Advanced EDID Management.....	133		
8.19.4. Setting the Parity	108	11.2. HDCP MANAGEMENT.....	134		
8.19.5. Setting the Stopbits.....	108	11.2.1. Protected and Unprotected Content	134		
8.19.6. Setting the Protocol	109	11.2.2. Disable Unnecessary Encryption.....	134		
8.19.7. Recalling Factory Default Settings on the Serial Port.....	109	11.2.3. HDCP 2.3.....	135		
8.20. SENDING CEC COMMANDS	109				
8.20.1. Sending a CEC Command in Text Format	109				

Applied SW/FW/HW Environment

All presented functions refer to the indicated products. The descriptions have been made while testing these functions in accordance with the indicated Hardware/Firmware/Software environment:

FW package	v1.6.3
Lightware Device Controller (LDC) version	v2.15.0b5
Lightware Device Updater V2 (LDU2) version	v2.34.0b1

Document Revision History

Rev.	Release date	Changes	Editor
1.0	13-08-2020	Initial release.	Tamas Forgacs
		...	
v2	20-10-2025	New document template, minor corrections	Laszlo Zsedenyi
v3	06-11-2025	Minor corrections	Laszlo Zsedenyi

Contact Us

sales@lightware.com

+36 1 255 3800

support@lightware.com

+36 1 255 3810

Lightware Visual Engineering PLC.

Gizella 51-57, Budapest H-1143, Hungary

www.lightware.com

©2025 Lightware Visual Engineering. All rights reserved.
All trademarks mentioned are the property of their respective owners.
Specifications are subject to change without notice.

1

Introduction

Thank you for choosing Lightware's MX2M series matrix switchers. In the first chapter we would like to introduce the device, highlighting the most important features in the sections listed below:

▶ Description	9
▶ Model Comparison	9
▶ Box Contents	10
▶ Features	11
▶ Typical Applications	14

1.1. Description

MX2M-FR24R is a member of the Lightware MX2 modular matrix switcher series, supporting uncompressed 4K UHD resolution at 60Hz with 4:4:4 sampling pattern and with down-conversion capabilities to 4:2:2, supporting HDCP 1.x and 2.3, 3D, Dolby TrueHD and DTS-HD Master Audio. The non-blocking matrix architecture distributes and switches 24 video signals to 24 outputs, distributed along six 4-port boards respectively per direction.

Full 4k HDMI 2.0
60Hz & 4:4:4 HIGH DEFINITION MULTIMEDIA INTERFACE

This versatile and customizable device is suitable for various types of applications, the actual application determining the choice of input and output boards to be included in the frame. It is a perfect choice for installations where a huge number of HDMI 2.0 compliant and other types of input and output video ports are required, including HDMI 2.0 and extension through fiber.

Besides the six 4-port input and six 4-port output video boards, there are four low speed installable slots for audio and other low speed signal connectivity.

Control for connected extenders is served by Ethernet layer. The Ethernet layer can also be used for IP extension, as well as for command injection for IR and serial control by third party devices.

For operation safety, power redundancy is available, and PSU drawers are field-exchangeable for ease of maintenance. The device also supports various IT security standards.

Model Denomination

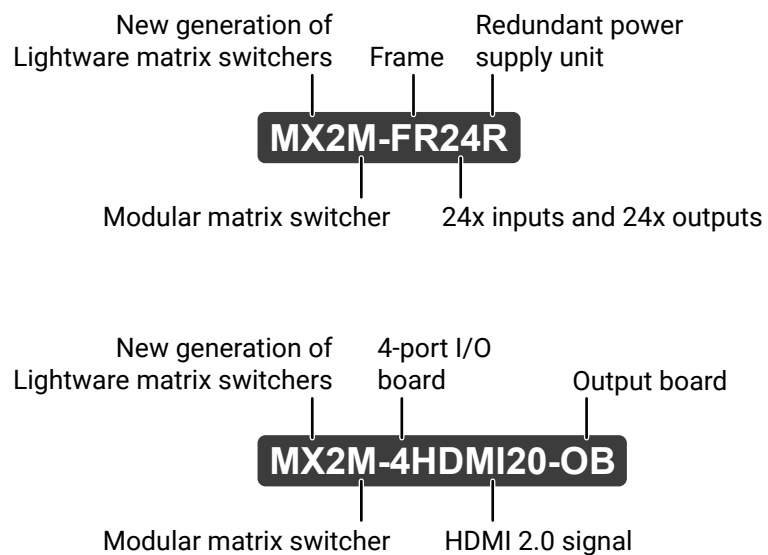

About the Serial Number

Lightware devices contain a label indicating the unique serial number of the product. The structure is the following:

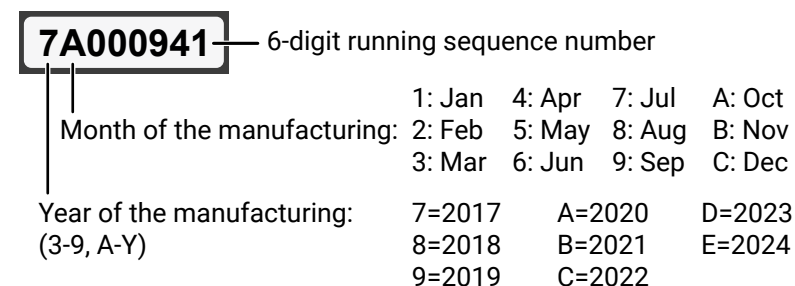

From 1st of October 2024, serial number format of Lightware devices is the following: the first two digits are of the year of manufacture, while the remaining digits make up the running sequence number.

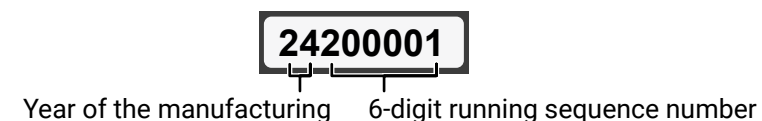



1.2. Model Comparison

The following table shows detailed information about the different frame types of the MX2M series matrix switchers.

Frame type	Equipment	PSU redundancy	Remote power capability	Nr. of device-powered I/O boards
MX2M-FR24R-F	Equipped with 1 pcs MX2M-PSU-500-F power drawer.	✗	✗	16
MX2M-FR24R-RF	Equipped with 2 pcs MX2M-PSU-500-F power drawers.	✓	✗	16
MX2M-FR24R-FP	Equipped with 1 pcs MX2M-PSU-1250-FP power drawer.	✗	✓	16
MX2M-FR24R-RFP	Equipped with 2 pcs MX2M-PSU-1250-FP power drawers.	✓	✓	16

1.3. Box Contents

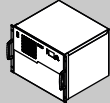
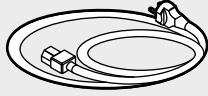
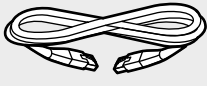
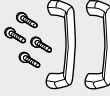
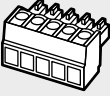
The following table describes all supplied and optional accessories of the MX2M series frames and I/O boards. The optional (not-supplied) accessories can be purchased separately; please contact sales@lightware.com.

		Supplied device	Supplied accessories				
		 Matrix switcher frame with rack mounting ears	 IEC power cable	 UTP patch cable (3 m)	 Handle pair with 4 pcs M5 flat head screws	 Phoenix® Combicon 5-pole connector	 Safety & Warranty Info; Quick Start Guide
Frames	MX2M-FR24R-F	✓	✓ (1x)	✓	✓	-	✓
	MX2M-FR24R-RF	✓	✓ (2x)	✓	✓	-	✓
	MX2M-FR24R-FP	✓	✓ (1x)	✓	✓	-	✓
	MX2M-FR24R-RFP	✓	✓ (2x)	✓	✓	-	✓
I/O board	MX2M-AUX-8AUDIO	-	-	-	-	✓ (8x)	-

1.4. Features

MX2M Hybrid Frame



4K Video without Compression

HDMI 2.0 signal switching with 4k@60Hz and RGB 4:4:4 color space, 18 Gbit/sec bandwidth.



Non-blocking Crosspoint Matrix Architecture

The router allows any input to be switched to any output or more outputs simultaneously.



Hybrid Modular System

Custom I/O sizes with several types of input and output boards give the flexibility for interfacing with different video sources and displays.



Hot Swappable I/O Boards

MX2M series I/O boards and the PSU drawers can be exchanged anytime without powering off the matrix router.



Maximum AV Compatibility

The matrix is compatible with the latest HDMI 2.0 standard, as well as with HDMI 1.x and DVI 1.0 standards.



Multilayer Signal Routing

In the MX2M product range Lightware added a third dimension of signal routing, the Media Layers, which provide the flexibility and freedom of independent signal switching. MX2M Hybrid frames manage as many Media Layers as signal types: there are as many individual routers as incorporated signal types.



HDCP Compliant

MX2M matrix switcher fulfills the HDCP standard. HDCP capability on the HDMI inputs can be disabled when non-protected content is extended.



No Signal Latency With Zero Frame Delay

The signal management architecture ensures that there is no delay added between the input and the output.



Advanced EDID Management

The user can emulate any EDID on the inputs independently, read out and store any attached monitor's EDID in the internal memory locations.



Pixel Accurate Reclocking

Each output has a clean, jitter free signal, eliminating signal instability and distortion caused by long cables or connector reflections on the input side.



Frame Detector and Signal Analysis

The exact video and audio signal format can be determined such as timing, frequencies, scan mode, HDCP encryption, color range, color space and audio sample rate.



Reliability and Redundancy

At Lightware we build our reputation and pay special attention on designing, developing and making truly reliable products. MX2M hybrid line frames have hot-swappable redundant power supplies. These frames were designed for mission critical operations where redundancy is key and high reliability is required. The redundant hot-swappable power drawers accept AC voltages from 100 to 240 Volts with 50 or 60 Hz line frequency on standard IEC connector.



Non-Volatile Memory

The matrix router starts with its latest configuration settings when powered on or after a power failure. Every setting is stored in a non-volatile memory.



Graphic Display and Rotary Jog Dial Control Knob

Easy setting and menu navigation are assured by the color graphic display and the comfortable jog dial control.



Built-in Website

Easy access from a web browser to control and configure the matrix in systems where the software is not allowed to be installed.



Ethernet Control

Multiple simultaneous TCP/IP connections are available with simple ASCII based protocol for controlling and configuring the matrix router.

**USB Control**

Easily accessible front panel USB configuration port.

**RS-232 Control**

Simple ASCII-based protocol can be used for switching, preset calling, status request, etc.

MX2M-4HDMI20 Series Boards**4K Video without Compression**

HDMI 2.0 signal switching with 4k@60Hz and RGB 4:4:4 color space, 18 Gbit/sec bandwidth.

**Consumer Electronics Control**

Supports transmitting standard CEC commands in order to remote control the source or sink device.

MX2M-DH-4DP12-IB Board**4K Video without Compression**

DisplayPort 1.2 signal switching with 4k@60Hz and RGB 4:4:4 color space, 18 Gbit/sec bandwidth.

**Restart Link Training**

Allows the DisplayPort Link Training to be restarted in case of no signal or bad quality, without unplugging the cable.

**DisplayPort Diagnostics and Management**

Provides detailed DisplayPort-specific connectivity information: AUX handshaking, 1/2/4 lane count, RBR/HBR/HBR2 datarates. DisplayPort AUX-channel analyzer helps debugging and analyzing handshaking problems.

MX2M-4OPTJ Series Boards**4K Video without Compression**

HDMI 2.0 signal switching with 4k@60Hz and RGB 4:4:4 color space, 18 Gbit/sec bandwidth.

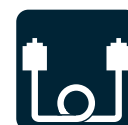
**Single Fiber Technology**

HDMI 2.0 signal with 4k@60Hz up to 18 Gbps signal transmission over a single fiber cable. The MX2M-4OPTJ series boards makes possible direct connection with the fully compatible HDMI20-OPTJ-90 series fiber transmitters and receivers.

**Consumer Electronics Control**

Supports transmitting standard CEC commands in order to remote control the source or sink device.

MX2M-4TPX Series Boards**4K Video without Compression**

HDMI 2.0 signal switching with 4k@60Hz and RGB 4:4:4 color space over 10 Gbit/sec bandwidth.

**SDVoE™ Compatibility**

The I/O boards are fully compatible with all HDMI-TPX-100 and HDMI-TPX-209 series extenders and other SDVoE point-to-point based devices.

**Remote Power**

MX2M-4TPX series I/O boards are PoE-compatible and they can supply remote power to HDMI-TPX-107 and HDMI-TPX-209 series extenders via the TPX connection.

**Consumer Electronics Control**

Supports transmitting standard CEC commands in order to remote control the source or sink device.

MX2M-AUX-8AUDIO Board**ADC and DAC Audio Signal Conversion**

Analog to digital and digital to analog audio signal conversion can be applied by the AUX board.

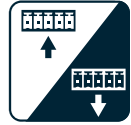
**Configurable Audio Ports**

All analog audio ports of the board can be configurable as input or output by the user by each.

MX2M-AUX-DANTE-32CH Board**Dante® or AES67 Audio**

Dante® or AES67 audio signal can be received and the audio of the HDMI / DisplayPort signal can be transmitted as up to 32-channel mono Dante® or AES67 signal over the dedicated RJ45 connectors.

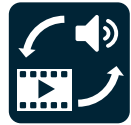
**Audio Embedding and De-embedding Function**

External analog audio signal can be embedded in the video stream when a port is configured as analog audio input and can be de-embedded from the video stream when a port is configured as output.

1.5. Typical Applications

1.5.1. Live Event Application

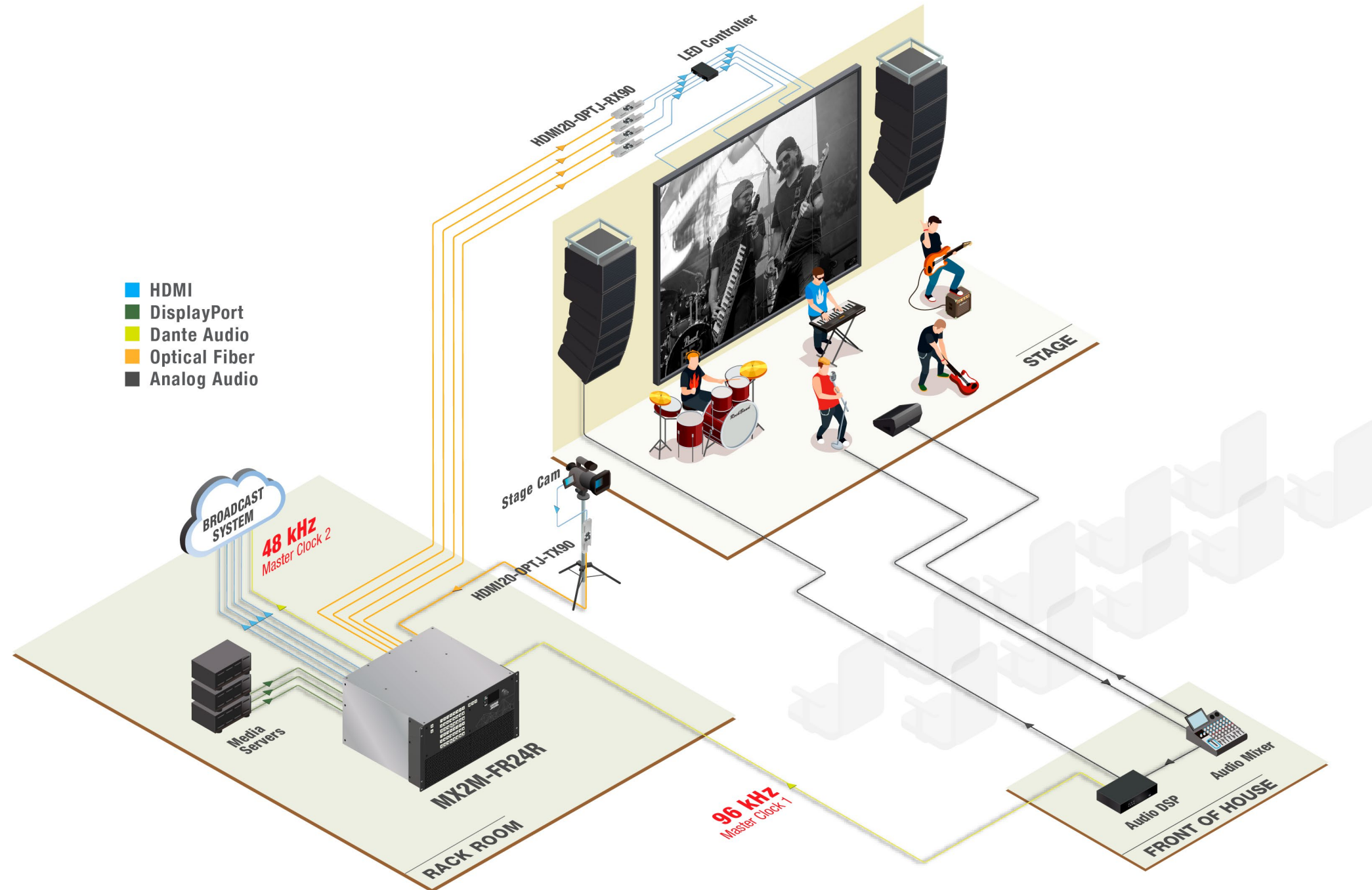

1.5.2. TV Studio Application

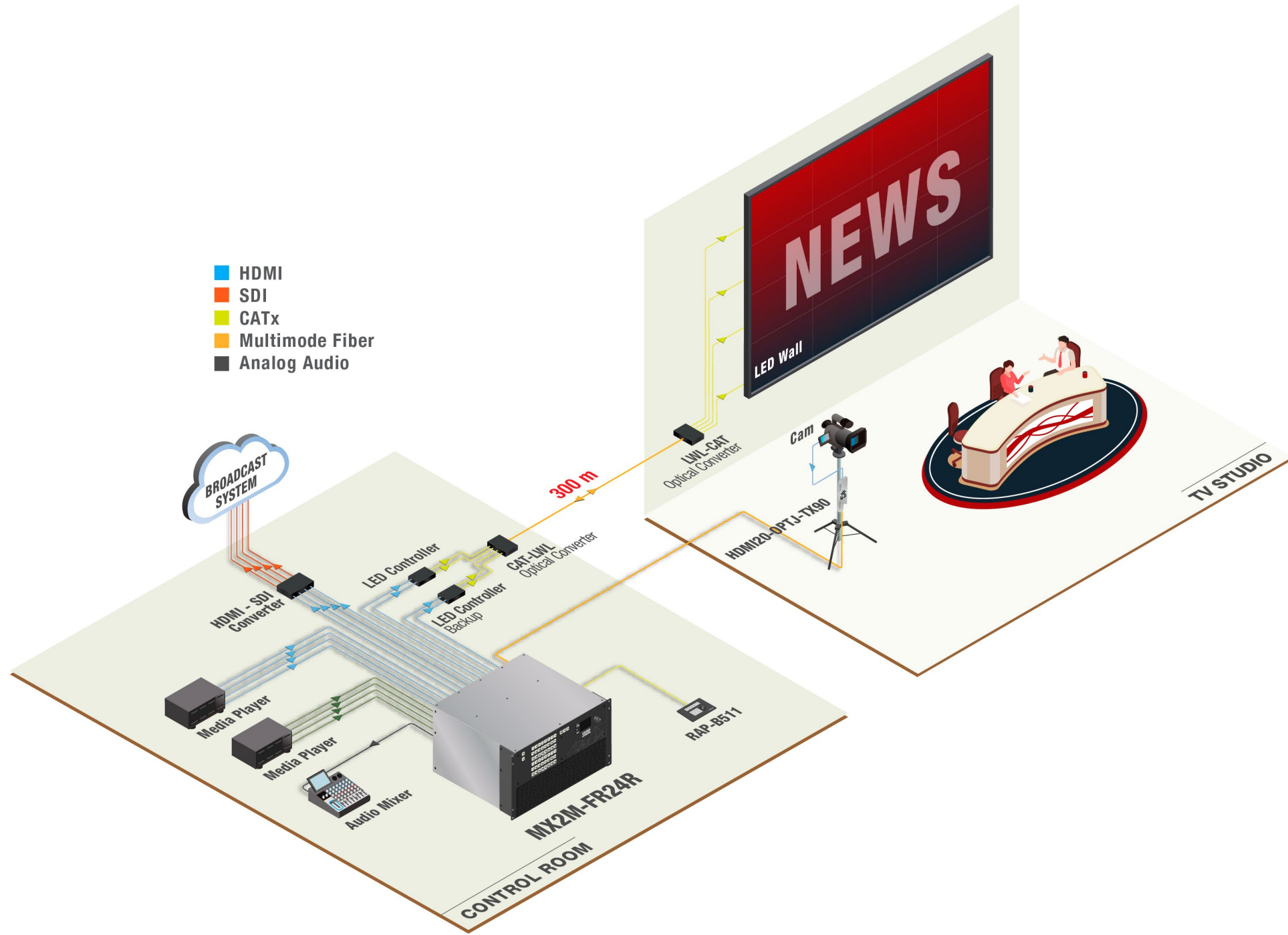

2

Product Overview

The following sections are about the physical structure of the device, input/output ports and connectors; software and hardware capabilities:

- ▶ Matrix Frame - Front View 17
- ▶ Matrix Frame - Rear View 18
- ▶ Auxiliary (AUX) Boards 19
- ▶ Input (IB) Boards 19
- ▶ Output (OB) Boards 21
- ▶ Power Drawers 22
- ▶ Front Panel LEDs of the Boards 22

2.1. Matrix Frame - Front View

MX2M-FR24R

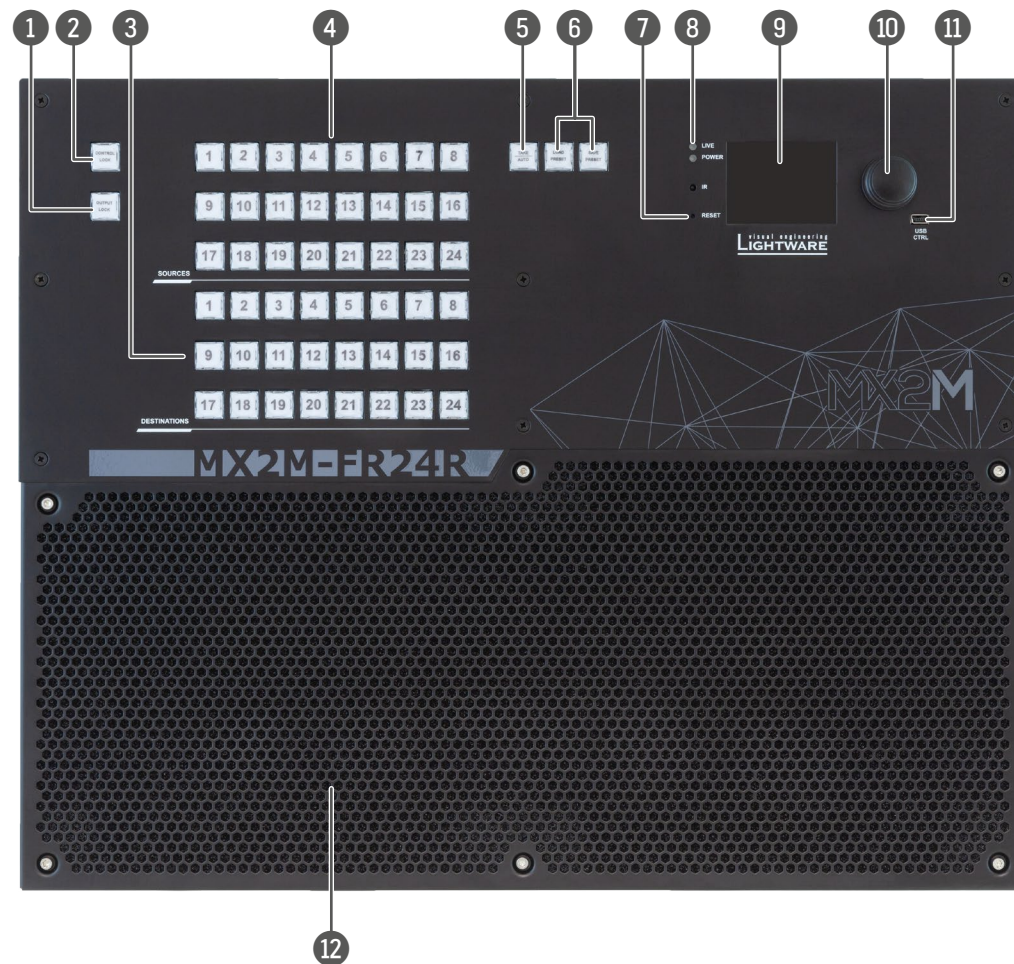

- 1 **Output lock** Locks and protects one or more outputs. See more details in the [Output Lock](#) section.
- 2 **Control lock** Disables or enables front panel button operations. Red light means the switching and function buttons are disabled. See more details in the [Control Lock](#) section.
- 3 **Destinations** Buttons to select an output or to see the state of an output. See more details in the [Switching Operations](#) section.

- 4 **Sources** Buttons to select an input, to select a preset number or to view the state of the selected input port. See more details in the [Switching Operations](#) section.
- 5 **Take / Auto** Switching between Take and Autotake working modes; keep the button pressed for 3 seconds to toggle the modes. See more details in the [Take / Autotake Mode](#) section.
- 6 **Preset buttons** Performing preset operations (Load and Save). See more details in the [Preset Operations](#) section.
- 7 **Reset button** Reboots the matrix; the same as switching it off and on again.
- 8 **Status LEDs** The status LEDs give immediate feedback about the matrix.

LIVE	<input type="radio"/>	off	The device is powered off.
	<input checked="" type="radio"/>	blinking (green)	The unit is on and operates properly.
POWER	<input type="radio"/>	off	The unit is powered off or it has internal voltage problem.
	<input checked="" type="radio"/>	on (green)	The device is powered on.
- 9 **LCD screen** LCD screen showing the most important settings and parameters in the front panel menu. See more details in the [Front Panel LCD Menu Operations](#) section.
- 10 **Jog dial control knob** Easy setting and menu navigation by the jog dial control. See more details in the [Front Panel LCD Menu Operations](#) section.
- 11 **USB control** USB connection for Lightware Device Controller (LDC) software.
- 12 **Ventilation grille and dust filter** To ensure the correct ventilation and avoid overheating, provide enough free space around the ventilation holes.

INFO: The rack ears allow to mount the device as a standard rack unit installation and the grips on the two sides of the unit help handling the matrix easier. See more details in the [Mounting Options](#) section.

2.2. Matrix Frame - Rear View

MX2M-FR24R

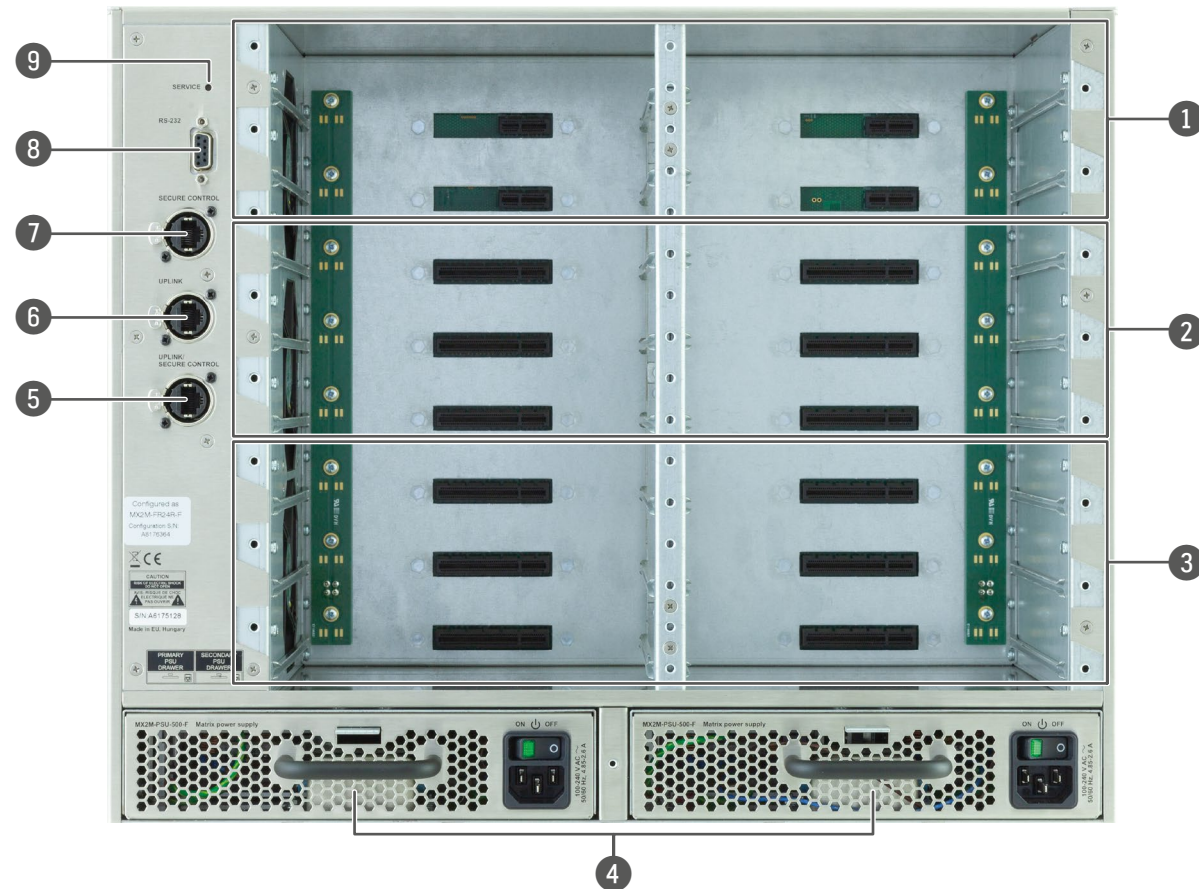

- ① **Auxiliary board slots** Board slots for the [Auxiliary \(AUX\) Boards](#). These slots support low-speed boards only.
- ② **Input board slots** Board slots for the AV [Input \(IB\) Boards](#). These slots support high-speed input boards and low-speed boards as well.
- ③ **Output board slots** Board slots for the AV [Output \(OB\) Boards](#). These slots support high-speed output boards and low-speed boards as well.

- ④ **Power supply units** Hot swap slots for [Power Drawers](#). The matrix has redundant power drawers that can be switched on and off without interrupting the video transmission. Using one or both of the power drawers at the same time is also possible. The double power drawer allows connecting them to two different AC power lines to ensure the continuous power for the matrix.
- ⑤ **Uplink / Secure control connector** Neutrik etherCON Ethernet connector with 1 Gbps Ethernet connection to control the device, firmware update purpose and for user Ethernet access.
- ⑥ **Uplink connector** Neutrik etherCON Ethernet connector with 1 Gbps Ethernet connections for user Ethernet access.
- ⑦ **Secure control connector** Neutrik etherCON Ethernet connector with 1 Gbps Ethernet connection to control the device and for firmware update purpose.
- ⑧ **RS-232 connector** 9-pole D-SUB connector for serial communication to control the device.
- ⑨ **Service button** Hidden button for special operations.

Layout of the Input/Output Board Slots and Power Drawer Slots

The following figure shows the layout of the auxiliary (AUX), input (IB), output (OB) board slots and the order of the power drawers on the rear side of the matrix.

See more details about the installation of the I/O boards in the [Board Installation and Handling](#) section.

See more details about the installation of the power supply units in the [Power Drawer Installation](#) section.

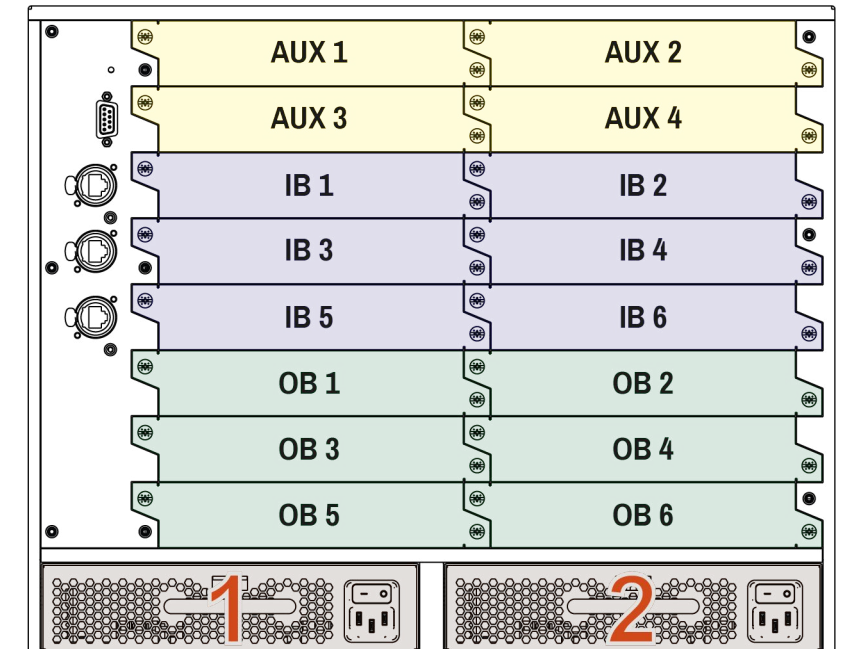

2.3. Auxiliary (AUX) Boards

2.3.1. MX2M-AUX-DANTE-32CH



Ports

- 4x RJ45 connectors for Dante® network audio

Features

- Transmission of 2 x 16 uncompressed mono audio channels from the audio layer to a Dante network
- Reception of 2 x 16 mono audio channels from a Dante network to the Audio layer
- Dante and AES67 support
- Redundant configuration for the Dante network
- Independent transmission of the same audio content from the Audio layer to two separate Dante networks
- Hot-swappable design

See more information about the **front panel LED operation** in the [Status LEDs](#) and the [Status LEDs of the SC Connectors](#) sections.

2.3.2. MX2M-AUX-8AUDIO

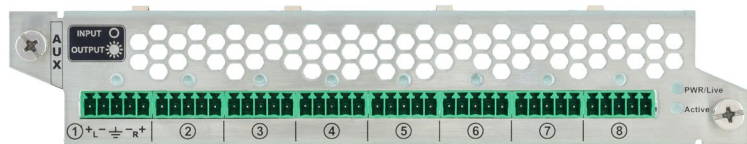

Ports

- 8x 5-pole Phoenix® connectors for analog audio input or output

Features

- Independently configurable audio interface direction with interface direction indicator (see more details about it in the [Analog Audio Port Configuration](#) section)
- ADC conversion of balanced or unbalanced stereo analog audio input to the audio layer
- DAC conversion of uncompressed audio from the Audio layer to the balanced stereo analog audio output
- Hot-swappable design

See more information about the **front panel LED operation** in the [Status LEDs](#) and the [Analog Audio Input/Output Indicator LEDs](#) sections.

2.4. Input (IB) Boards

2.4.1. MX2M-4HDMI20-IB

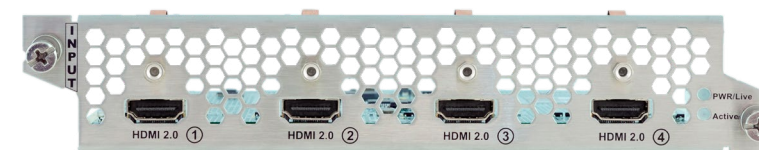

Ports

- 4x HDMI input connectors supporting HDMI 2.0 standard

Features

- Uncompressed video up to 18 Gbps datarate (600 MHz pixel clock)
- 4K@60Hz 4:4:4, 18 Gbps bandwidth
- HDMI 2.0 compliant
- HDCP 1.x and 2.3 support
- Audio signal passthrough and de-embedding to the Audio layer
- HDMI input ports have flange mounting option
- Hot-swappable design

See more information about the **front panel LED operation** in the [Status LEDs](#) section.

2.4.2. MX2M-4OPTJ-IB

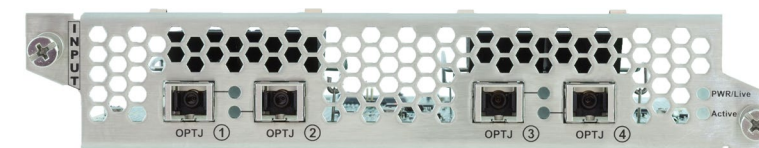

Ports

- 4x multimode SC simplex input connectors supporting HDMI 2.0 standard

Features

- Single Fiber Technology, multimode transmission via SC connector
- Uncompressed video up to 18 Gbps datarate (600 MHz pixel clock)
- 4K@60Hz 4:4:4, 18 Gbps bandwidth
- Compatible with HDMI20-OPTJ-TX90 fiber optical extender
- Audio signal passthrough and de-embedding to the Audio layer
- Hot-swappable design

See more information about the **front panel LED operation** in the [Status LEDs](#) and the [Status LEDs of the SC Connectors](#) sections.

2.4.3. MX2M-4TPX-IB

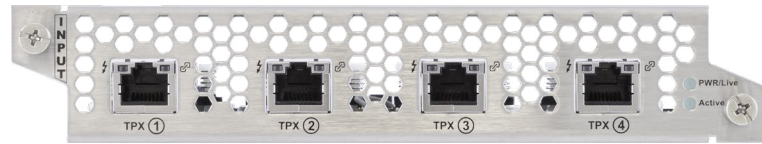

Ports

- 4x RJ45 input connectors for SDVoE point-to-point connection supporting HDMI 2.0 standard

Features

- 4K@60Hz 4:4:4, 18 Gbps bandwidth
- HDMI 2.0 compliant
- HDCP 1.x and 2.3 support
- Compatible with HDMI-TPX-100 and HDMI-TPX-200 series extenders
- De-embedding audio from the incoming SDVoE streams to the Audio layer
- Hot-swappable design

See more information about the **front panel LED operation** in the [Status LEDs](#) and the [Status LEDs of the TPX Connectors](#) sections.

2.4.4. MX2M-DH-4DP12-IB



Ports

- 4x DisplayPort input connectors supporting DisplayPort 1.2 standard

Features

- DisplayPort 1.2 compliant
- DisplayPort input signals are converted to HDMI signals via the built-in chipset on each port ¹
- Supported input format of 4K@60Hz with 4:4:4 sampling pattern and 10 bit per component
- Supports conversion from 4K/UHD at 60Hz 4:4:4 10bit to 4K/UHD at 60 Hz YCbCr 4:2:2 10 bit
- Audio signal passthrough and de-embedding to the Audio layer
- The board is a perfect fit for environments that primarily utilize DisplayPort connectivity for video signal transmission, such as laptops and high-end monitors, without the need for any additional adapters or dongles. ²
- Hot-swappable design

See more information about the **front panel LED operation** in the [Status LEDs](#) section.

¹ Input signals that do not fit in the HDMI 2.0 data speeds of 18Gbps can be converted to 4:2:2 while maintaining bit depth, thus allowing for HDR transmission.

² Ports on the MX2M-DH-4DP12-IB board are recognized by the connected DisplayPort source as DP-to-HDMI converters. Furthermore, it's important to note that DP Multi-Stream (MST), Dual-mode DisplayPort (DP++), Adaptive-Sync and FreeSync™ are not supported.

INFO: When the DisplayPort source sends RGB 4:4:4 10-bit HDR signal, then it will be converted to 8-bit HDMI signal, **if the AV signal exceeds the bandwidth limitation of the HDMI 2.0 standard**, else the original content is transmitted. Enabling YCbCr 4:2:2 conversion will save bandwidth by chroma subsampling and preserve the color depth.

2.5. Output (OB) Boards

2.5.1. MX2M-4HDMI20-OB



Ports

- 4x HDMI output connectors supporting HDMI 2.0 standard

Features

- Uncompressed video up to 18 Gbps datarate (600 MHz pixel clock)
- 4K@60Hz 4:4:4, 18 Gbps bandwidth
- HDMI 2.0 compliant
- HDCP 1.x and 2.3 support
- Audio signal passthrough and embedding from the Audio layer
- HDMI output ports have flange mounting option
- Hot-swappable design

See more information about the **front panel LED operation** in the [Status LEDs](#) section.

2.5.2. MX2M-4OPTJ-OB

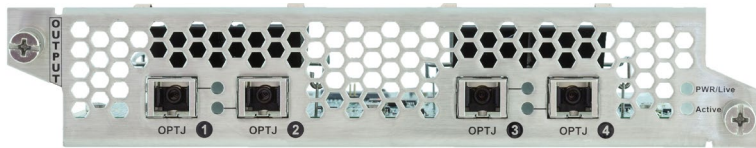

Ports

- 4x multimode SC simplex output connectors supporting HDMI 2.0 standard

Features

- Single Fiber Technology, multimode transmission via SC connector
- Uncompressed video up to 18 Gbps datarate (600 MHz pixel clock)
- 4K@60Hz 4:4:4, 18 Gbps bandwidth
- Compatible with HDMI20-OPTJ-RX90 fiber optical extender
- Audio signal passthrough and embedding from the Audio layer
- Hot-swappable design

See more information about the **front panel LED operation** in the [Status LEDs](#) and the [Status LEDs of the SC Connectors](#) sections.

2.5.3. MX2M-4TPX-OB

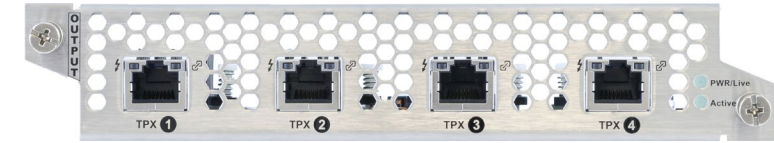

Ports

- 4x RJ45 output connectors for SDVoE AVX connection supporting HDMI 2.0 standard

Features

- 4K@60Hz 4:4:4, 18 Gbps bandwidth
- HDMI 2.0 compliant
- HDCP 1.x and 2.3 support
- Compatible with HDMI-TPX-100 and HDMI-TPX-209 series extenders
- Audio signal passthrough and embedding from the Audio layer
- Hot-swappable design

See more information about the **front panel LED operation** in the [Status LEDs](#) and the [Status LEDs of the TPX Connectors](#) sections.

2.6. Power Drawers

2.6.1. MX2M-PSU-500-F



Features

- 500 W power output
- Built-in power button
- One PSU drawer is able to supply the power requirement of 16 pcs I/O boards
- Hot-swappable design

2.6.2. MX2M-PSU-1250-FP

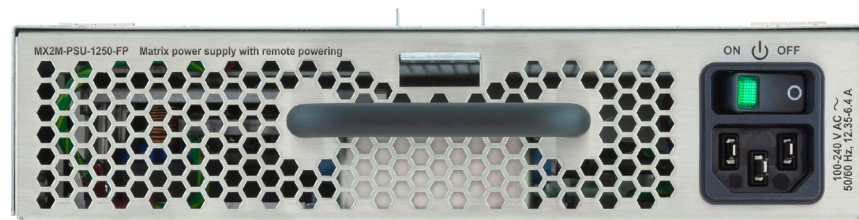

Features

- 1250 W power output
- Built-in power button
- One PSU drawer is able to supply the power requirement of 16 pcs I/O boards
- Provides local power for the matrix frame, for the IO boards as well as for remote powering (PoE) of PD devices connected to the various IO boards
- Hot-swappable design

2.7. Front Panel LEDs of the Boards

2.7.1. Status LEDs

Affected auxiliary and I/O boards:









- [MX2M-AUX-DANTE-32CH](#)
- [MX2M-AUX-8AUDIO](#)
- [MX2M-4HDMI20-IB](#)
- [MX2M-4OPTJ-IB](#)
- [MX2M-4TPX-IB](#)
- [MX2M-DH-4DP12-IB](#)
- [MX2M-4HDMI20-OB](#)
- [MX2M-4OPTJ-OB](#)
- [MX2M-4TPX-OB](#)

PWR/Live		
	off	The board is not powered.
	lit at 50% brightness	The board is under booting procedure.
	blinking fast between 0% and 100% brightness	The board is fitted in an inappropriate slot (input in an output, output in an input slot). Hence, it is not passing video.
	blinking between 50% and 100% brightness	The board is operational (the embedded software is running on the controller).
Active		
	off	The control sequence has not been completed.
	on	The control sequence has been completed and the device is being controlled by the matrix switcher.
	blinking (slow)	The device firmware is under firmware update procedure (bootload mode).
	blinking (fast)	The board is fitted in an inappropriate slot (input in an output, output in an input slot). Hence, it is not passing video.

2.7.2. Status LEDs of the SC Connectors

Affected I/O boards:







- [MX2M-4OPTJ-IB](#)
- [MX2M-4OPTJ-OB](#)

OPTJ 1 / OPTJ 2 / OPTJ 3 / OPTJ 4		
	off	The optical RX module is not powered.
	blinking (red)	No fiber is connected and the laser is disabled.
	on (yellow)	Fiber detected but link initialization failed.
	blinking (green)	Link is receiving video without HDCP encryption.
	on (green)	Link is receiving video with HDCP 1.x encryption.
	on (blue)	Link is receiving video with HDCP 2.x encryption.
	on (pink)	The optical RX module is in bootload (firmware update) mode.
	blinking (pink)	

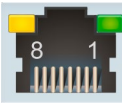
2.7.3. Dante Connector LEDs

Affected auxiliary board:



- [MX2M-AUX-DANTE-32CH](#)

	LED1 (left side)	amber		off	not linked
				on	no activity
				blinking	activity
	LED2 (right side)	green		off	0 Mbit/s
				on	1000 Mbit/s

2.7.4. Analog Audio Input/Output Indicator LEDs

Affected auxiliary board:







- [MX2M-AUX-8AUDIO](#)

Input / Output indicator		
	off	The port is configured as analog audio input.
	on	The port is configured as analog audio output.

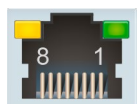
2.7.5. Status LEDs of the TPX Connectors

Affected auxiliary board:

- [MX2M-4TPX-IB](#)
- [MX2M-4TPX-OB](#)

	LED1 (left side)	amber / green		off	No connection is established between the board and the receiver unit.
				on	Connection is established with 10G / 5G / 2.5G bandwidth.
				blinking	Link training is in progress.
	LED2 (right side)	green		off	No data transmission on the port.
				on	Data transmission is active.

3

Front Panel Control

This chapter is about the operating of operating the device, describing the functions that are available by the front panel controls:

- ▶ Front Panel Button Operations 25
- ▶ Front Panel LCD Menu Operations 28

3.1. Front Panel Button Operations

The following section describes the crosspoint switching possibilities using the dedicated buttons on front panel of the matrix frame.

3.1.1. Take / Autotake Mode

The matrix switcher has two different switching modes: **Take** and **Autotake**. If the **Take** button is unlit, **Take** mode is active. When the **Take** button continuously illuminates green, **Autotake** mode is selected.

Press and hold the **Take** button for two seconds to change between **Take** and **Autotake** modes. `#button #crosspoint #switch #takemode #autotakemode`

Take Mode

DEFINITION: The **Take** mode allows the user to connect or disconnect multiple outputs to an input at once, but the layout must be confirmed (executed) by the Take button as a final step.



The commands are only realized when the **Take** button is pressed. If no button is pressed for two seconds, all preselected actions (which were not realized by pressing **Take**) will be ignored, and the router returns to its idle state. This mode is useful when time delay is not allowed between multiple switching.

Autotake Mode

DEFINITION: The **Autotake** mode means the switching actions are executed immediately (without user confirmation).



The switching occurs immediately upon pressing one of the input selector buttons. Autotake mode is useful when immediate actions must be done or fast switching is needed between sources on a particular destination. In this mode switching occurs immediately upon pressing one of the input selector buttons.

3.1.2. View Crosspoint State

The current switching status can be checked on the front panel by using the front panel buttons. The crosspoint state is displayed slightly different in **Take** or **Autotake** modes because of the different switching methods.

INFO: View mode does not mean that the router has to be switched in different modes, viewing and switching can be done after each other, without pressing any special buttons.

View Current State in Take Mode

If the router is in **Take** mode, the user can verify both input and output connections. In **Take** mode no accidental change can be done unless **Take** button is pressed.

Press and release a **source button**. Now the selected source button and all destination buttons that are currently connected to the selected source will light up. This informative display will remain active for three seconds, then all buttons turn dark.

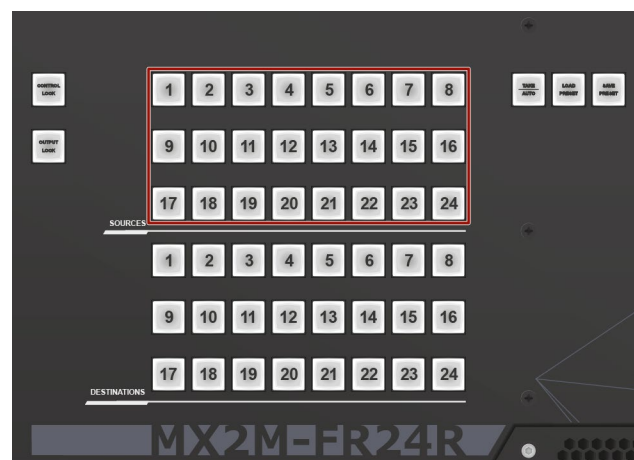

View Current State in Autotake Mode

In Autotake mode only the states of the destinations can be viewed.

Press and release the required **destination** button. Now the source button that is connected to the selected destination will light up. If no source button is lighting, the selected destination is muted or disconnected. By pressing another destination button, the state of that destination can be seen.

ATTENTION: Be careful, as if a source button is pressed in AUTOTAKE mode, it is immediately connected to the last selected destination.

INFO: Muting or disconnecting an output cannot be done in Autotake mode.



3.1.3. Switching Operations

Changing Connections in Take Mode

- Step 1.** Press and release the desired **source** button. The pressed source button and all destination buttons that are currently connected to this source will light up. This is an informative display about the current status of the selected input (view only).
- Step 2.** Press and release the desired **destination** button(s) that has to be connected to the selected source. The preselected destination button(s) start(s) blinking.
- Step 3.** Press and release the **Take** button to execute switching. Now the selected input is switched to the selected output or to the multiple outputs.

ATTENTION: A source button can be pressed twice to preselect all outputs. Outputs that are connected to the pressed input light up and all other outputs start to blink. Some outputs can be unselected if needed, and then pressing **Take** executes the switching.

INFO: If the pressed destination is locked, then it can not be selected. This is indicated by a short flash of the **Output lock** when a locked destination is pressed.

`#crosspoint #switch #takemode`

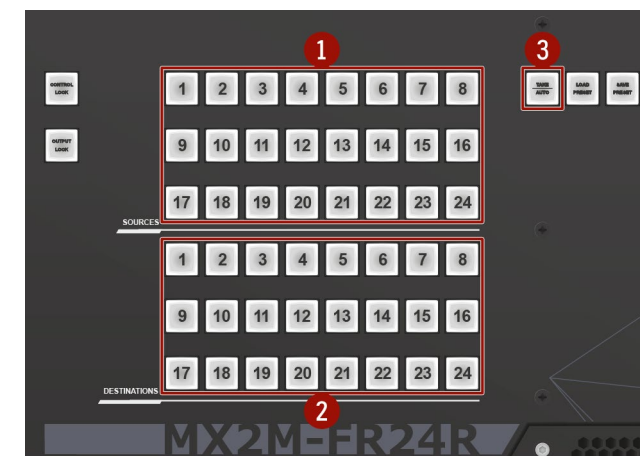

Disconnecting or Muting in Take Mode

- Step 1.** Press and release the selected **source** button. The pressed source button and all destination buttons that are currently connected to this source will light up.
- Step 2.** Press and release the desired green lighting **destination** button. The pressed destination or multiple destinations will turn dark.
- Step 3.** Press and release the **Take** button to execute disconnection.

INFO: Deselected destinations are disconnected from any source, thus output devices will display black image or no signal message, or will turn off automatically.

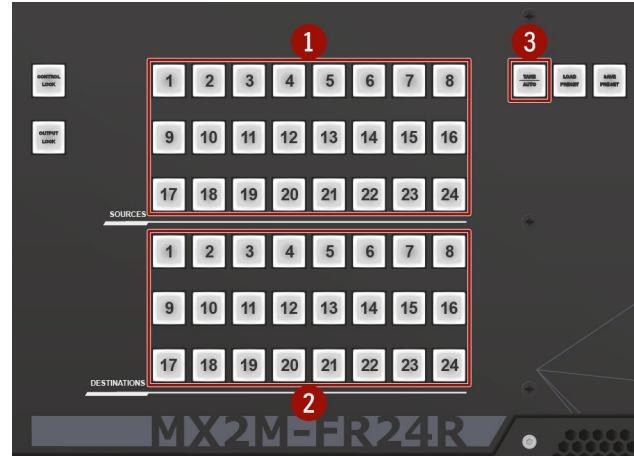

Changing Connections in Autotake Mode

- Step 1.** Press and release the desired **destination** button. The pressed destination button and the currently connected source button light up green. If no source is connected (the output is muted), no source button will light up.
- Step 2.** Press and release the desired **source** button. Switching is executed immediately. Switching between sources to the selected destination can be done directly.

Disconnecting or Muting in AUTOTAKE Mode

To prevent accidental muting, this action is inhibited (disabled) in Autotake mode. Pressing a source button twice would cause accidental disconnecting.

#crosspoint #switch #autotakemode

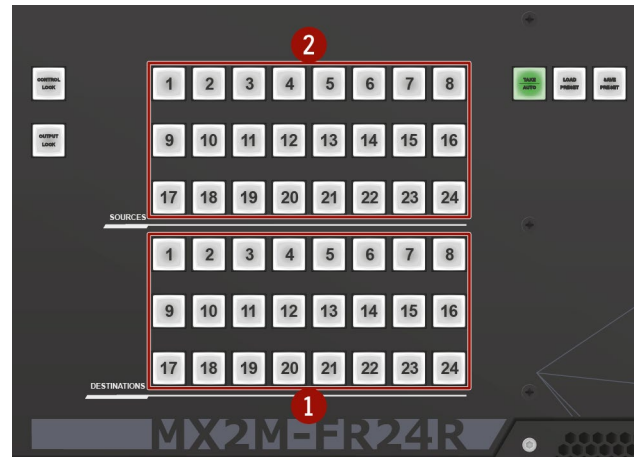

3.1.4. Preset Operations

- DEFINITION:** A **preset** stores a configuration regarding all input connections and mute state for all outputs.
- INFO:** The matrix switcher has 24 user programmable presets. All presets are stored in a non-volatile memory; the router keeps presets even in the case of a power down. Memory numbers are assigned to source buttons 1 to 24. If the frame has fewer buttons, the higher numbered presets are accessible only through software control.

Saving a Preset in Take Mode *#preset*

Create the desired connections that have to be saved.

- Step 1.** Press and release the **Save preset** button.
- Step 2.** Press and release a **source** button according to the desired memory address (source 1 to 24).
- Step 3.** Press and release the **Take** button. Now the current configuration is stored in the selected memory.

ATTENTION: Preset save action always stores the current configuration for all outputs including mute state, but ignoring lock state.

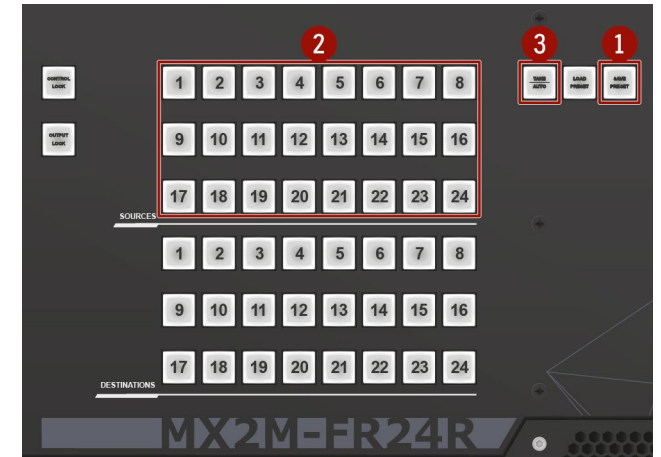

Loading a Preset in Take Mode

- Step 1.** Press and release the **Load Preset** button.
- Step 2.** Press and release a **source** button according to the desired memory address (source 1 to 24).
- Step 3.** Press and release the **Take** button. Now the selected preset is loaded.

ATTENTION: Loading a preset modifies all output states that are not currently locked.

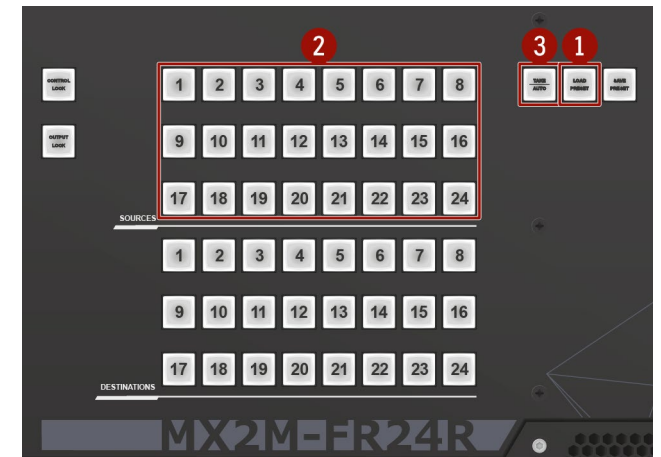

Saving a Preset in Autotake Mode

Create the desired connections that have to be saved.

Step 1. Press and release **Save Preset** button.

Step 2. Press and release a **source** button according to the desired memory address (source 1 to 24). Now the current configuration is stored in the selected memory.

ATTENTION: Preset save action always stores the current configuration for all outputs including mute state, but lock state is ignored.

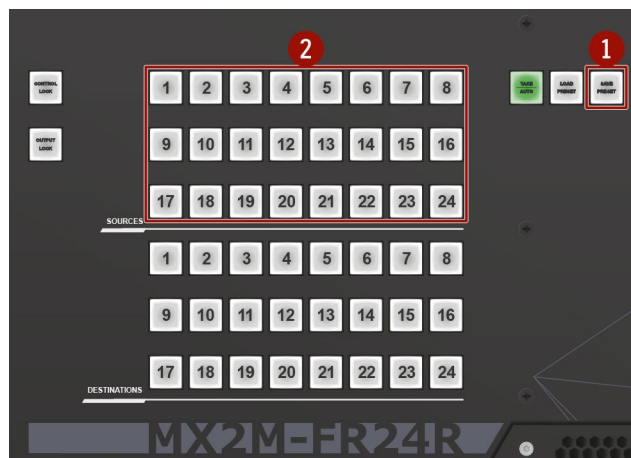

Loading a Preset in Autotake Mode

Step 1. Press and release **Load Preset** button.

Step 2. Press and release a **source** button according to the desired memory address (source 1 to 24). Now the selected preset is loaded.

ATTENTION: Loading a preset modifies all output states that are not currently locked.

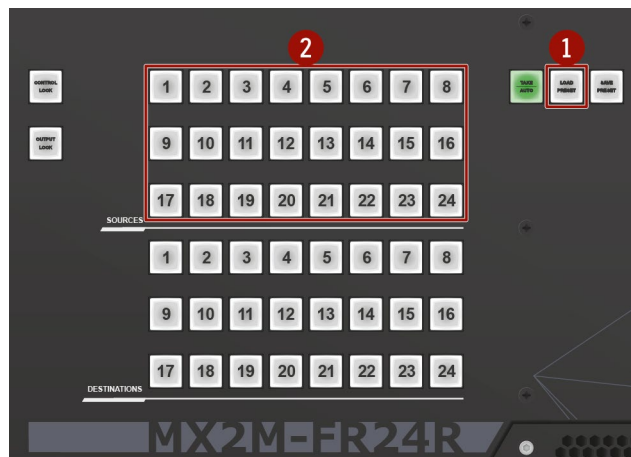

3.1.5. Output Lock

DEFINITION: The **Output lock** means that an input port is locked to an output port, and no input change or muting can be executed on that particular output port.

Using Lightware matrix it is possible to lock a state of the destination. This feature prevents an accidental switching to the locked destination in the case of an important signal. Destinations can be independently locked or unlocked. Locking a destination does not affect other destinations. `#lock #unlock #outputlock`



View Locked Outputs in Take Mode

Step 1. Press and release the **Output Lock** button.

Step 2. The **Output Lock** button starts to blink and all the buttons of any locked destinations light up and remain illuminated for three seconds.

Locking an Output in Take Mode

Step 1. Press and release the **Output Lock** button. Now the Output Lock button starts to blink and the buttons of all the locked outputs illuminate green (view state). If no button is pressed for three seconds, the router returns to idle state.

Step 2. Press the desired **destination** buttons. If an unlit destination button is pressed, it starts to blink, indicating that it is preselected for output locking.

Step 3. Press and release the **Take** button. The selected destinations are now locked.

Unlocking an Output in Take Mode

Step 1. Press and release the **Output Lock** button. Now the Output Lock button starts to blink and all the locked output's buttons illuminate green (view state). If no button is pressed for three seconds, the router returns to idle state.

Step 2. If an illuminating **destination** button is pressed, it goes off to indicate that it is preselected for unlocking.

Step 3. Press and release the **Take** button. The deselected destinations are now unlocked.

View Locked Outputs in Autotake Mode

In **Autotake** mode a destination is selected all the time. Therefore the currently selected output and input buttons are illuminated. The **Output Lock** button illuminates regarding the lock state of the current output.

Viewing all locked outputs is not possible in **Autotake** mode, as pressing the **Output Lock** button instantly locks or unlocks the current output.

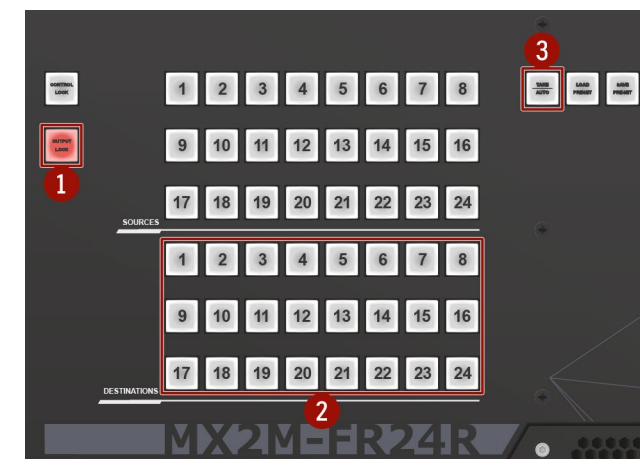
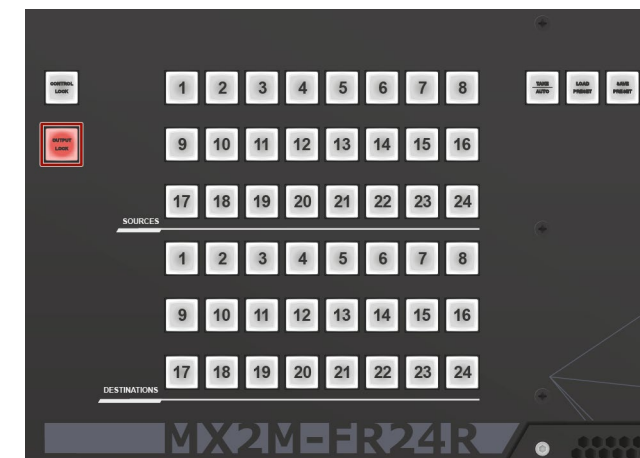

Locking an Output in Autotake Mode

- Step 1.** Press and release the required **destination** button. Now the selected destination button and the currently configured source button light up (view mode).
- Step 2.** Press and release the **Output Lock** button. Now the Output Lock button lights up in red, and lock function is activated at once. No source can be changed at the locked destination.

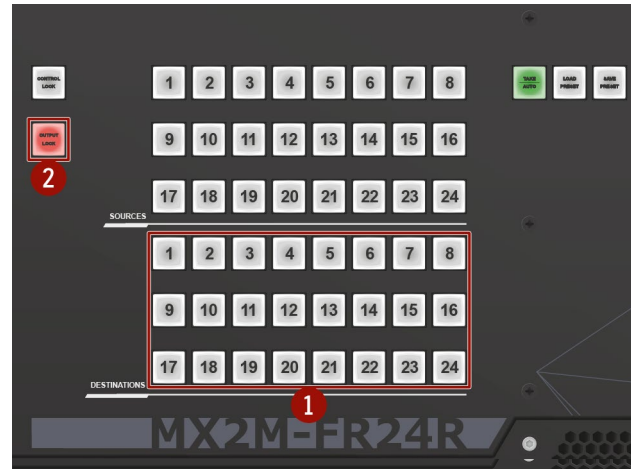

Unlocking an Output in Autotake Mode

- Step 1.** Press and release the required **destination** button that was previously locked. Now the selected destination button, the currently configured source button and the Output Lock button light up.
- Step 2.** Press and release the **Output Lock** button (deselection). Now the Output Lock button turns off and the port has been unlocked.

3.1.6. Control Lock

DEFINITION: The **Control Lock** means to disable the front panel buttons.

While the front panel buttons are disabled, the RS-232, USB and Ethernet control are still enabled. If the button is not illuminated, front panel button operations are enabled. If it illuminates red continuously, front panel operations are inhibited (including LCD menu).

Press and hold the **Control lock** button for 3 seconds to toggle the control lock state. `#button #controllock`

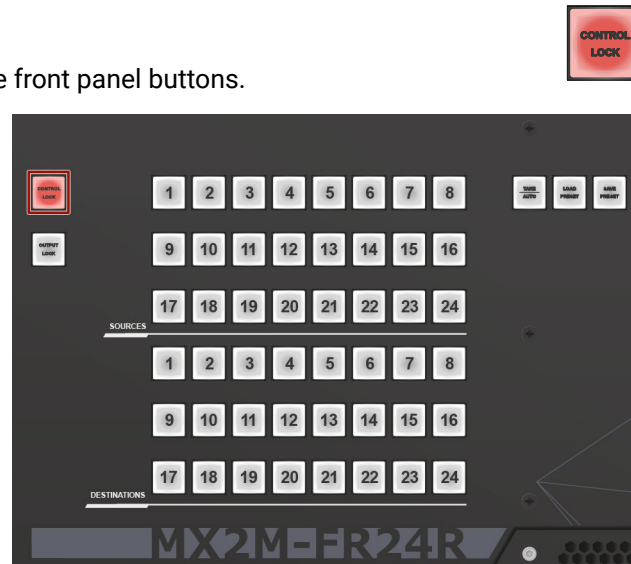

3.2. Front Panel LCD Menu Operations

3.2.1. Introduction

The company logo is displayed on the screen during the boot-up. The main menu is displayed after about 30 seconds and the device is ready for use.

Menu Navigation

The front panel has a color LCD that shows the most important settings and parameters structured in a menu. The jog dial control knob can be used to navigate between the menu items or change the value of a parameter. The knob can be pressed to enter a menu or edit/set a parameter.

TIPS AND TRICKS: The faster you rotate the jog dial, the faster the parameter list is scrolled.

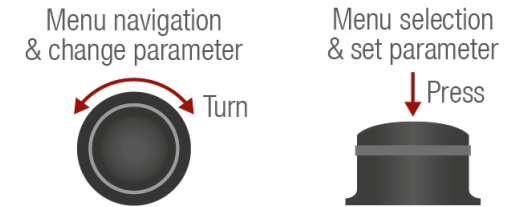

The Menu Structure

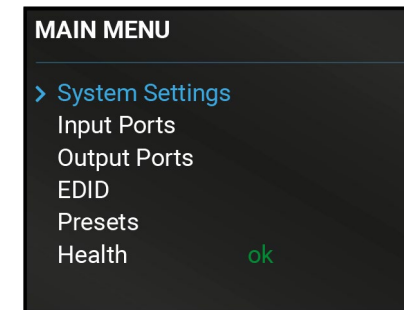

Parameter Selection

The **blue** colored line means the selected menu/parameter, the **green** one means the current setting.

Enter the Menu / Submenu

The **>** icon before the line indicates the additional submenus. Click with the rotary to enter.

The **•** icon shows that there is no submenu or setting possibility.

MAIN MENU

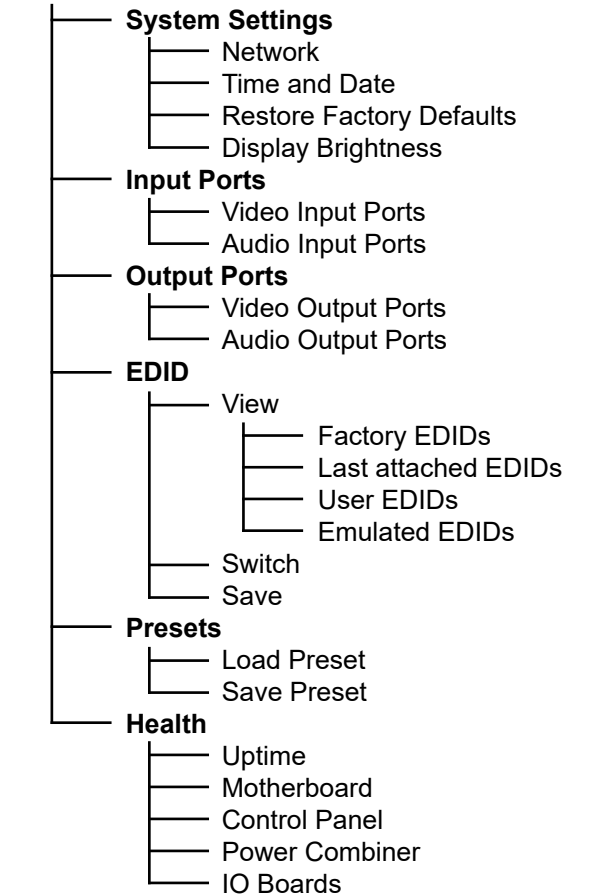

3.2.2. System Settings Menu

Network

The parameters of the network connection can be set in this submenu. The first three lines (IP, Subnet, and Gateway parameters) show the current settings. If the DHCP option is disabled, three more parameters are listed, which can be set for a static IP address: *#network #ipaddress #dhcp*

- Static IP,
- Static subnet,
- Static gateway.

ATTENTION: If you change the network settings, always press the Save option under Network menu (not only in the submenu of the parameter) to apply the new settings.

Time and Date

The internal clock and date that is used for logging events can be set in this submenu. *#time #date*

Restore Factory Defaults

The default settings can be reloaded in this submenu, for details, see the [Factory Default Settings](#) section. *#factory*

Display Brightness

The brightness of the LCD can be set from 1 to 10 on a scale.

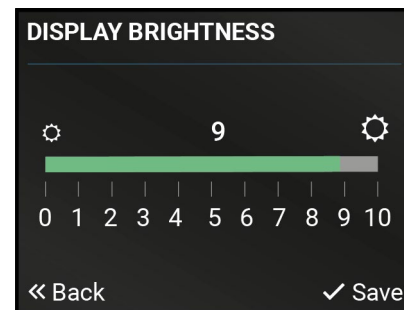
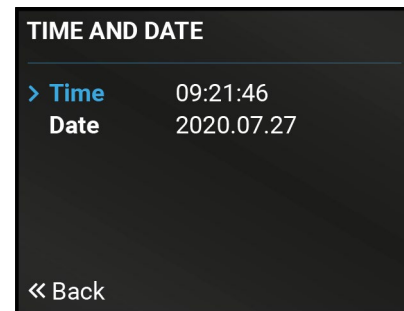
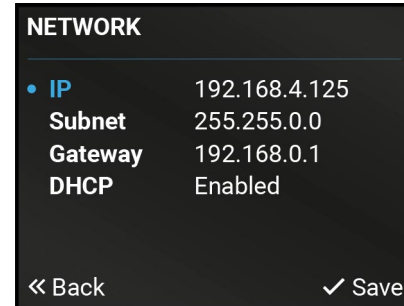

3.2.3. Input Ports Menu

Video Input Ports

The most important status information of the video input ports are available in the menu.

INFO: The number of the video input ports depends on the installed IB boards in the matrix switcher.

Legend of the Icons

The icons display information about the port and the incoming signals.

Icon	Icon is white (inactive)	Icon is blue (active)
	Signal is not encrypted with HDCP	Signal is encrypted with HDCP
	No audio signal in the video stream	Audio is embedded in the video stream
	Signal is not present	Signal is present
	Source is not connected	Source is connected
	Port is unmuted	Port is muted
	Port is unlocked	Port is locked

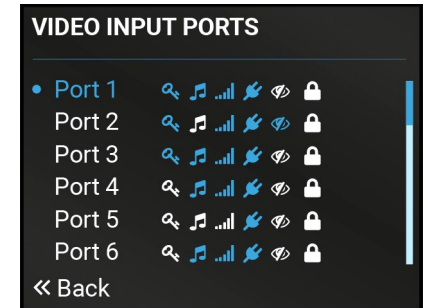

Audio Input Ports

The most important status information of the audio input ports is available in the menu.

INFO: The number of the audio input ports depends on the installed auxiliary and IB boards in the matrix switcher.

Legend of the Icons

The icons display information about the audio port and the incoming signals.

Icon	Icon is white (inactive)	Icon is blue (active)
	Signal is not present	Signal is present
	Source is not connected	Source is connected
	Port is unmuted	Port is muted
	Port is unlocked	Port is locked

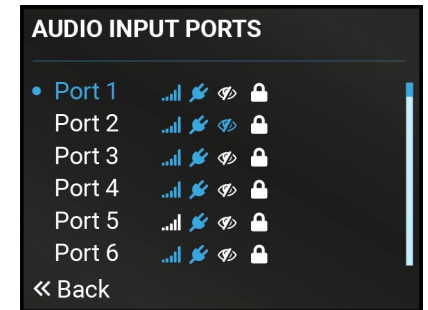

3.2.4. Output Ports Menu

Video Output Ports

The most important status information of the video output ports are available in the menu.

INFO: The number of the video output ports depends on the installed OB boards in the matrix switcher.

Legend of the Icons

The icons show information about the port and the transmitted signals.

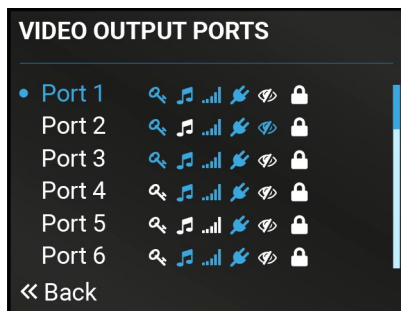

Icon	Icon is white (inactive)	Icon is blue (active)
	Signal is not encrypted with HDCP	Signal is encrypted with HDCP
	No audio signal in the video stream	Audio is embedded in the video stream
	Signal is not present	Signal is present
	Sink is not connected	Sink is connected
	Port is unmuted	Port is muted
	Port is unlocked	Port is locked

Audio Output Ports

The most important status information of the audio output ports is available in the menu.

INFO: The number of the audio output ports depends on the installed auxiliary and OB boards in the matrix switcher.

Legend of the Icons

The icons display information about the port and the transmitted signals.

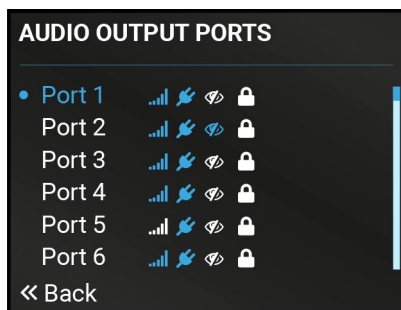

Icon	Icon is white (inactive)	Icon is blue (active)
	Signal is not present	Signal is present
	Sink is not connected	Sink is connected
	Port is unmuted	Port is muted
	Port is unlocked	Port is locked

3.2.5. EDID Menu

Advanced EDID Management is available in the front panel LCD menu, which allows to view an EDID, switch, or save it to the User EDID memory. See more information about EDID technology in [EDID Management](#) section. The EDID memory structure of the device can be found in [Advanced EDID Management](#) section.

View

Select the desired EDID memory block: **Factory EDIDs**, **Last attached EDIDs**, **User EDIDs**, or **Emulated EDIDs**. Select the Name item and press the knob. Use the jog dial to step between the EDIDs. The following information can be checked:

- Preferred Resolution
- Monitor Name
- Audio Info

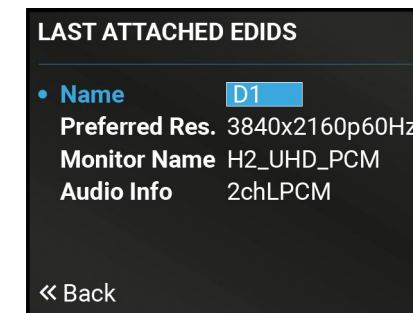

Switch

The submenu looks similar as the View submenu, but in this case, the Destination is also listed. To change an EDID, do the following steps:

- Step 1. Navigate to the **EDID / Switch** submenu.
- Step 2. Select the **Source** EDID item and press the knob. Use the jog dial to select the desired EDID (F1-F148, U1-U100, or D1-D24) and press the knob.
- Step 3. Select the **Destination** item and press the knob. Use the jog dial to select the desired EDID memory (E1-E2, All) and press the knob.
- Step 4. Navigate to the **Switch** option and press the knob.

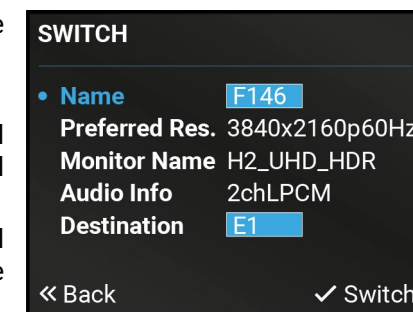

Save

The EDID of a connected sink can be saved to the User EDID memory as follows:

- Step 1. Navigate to the **EDID / Save** submenu.
- Step 2. Select the **Source** EDID item and press the knob. Use the jog dial to select the desired EDID (D1-D4) and press the knob.
- Step 3. Select the **Destination** item and press the knob. Use the jog dial to select the desired EDID memory (U1-U12) and press the knob.
- Step 4. Navigate to the **Save** option and press the knob.

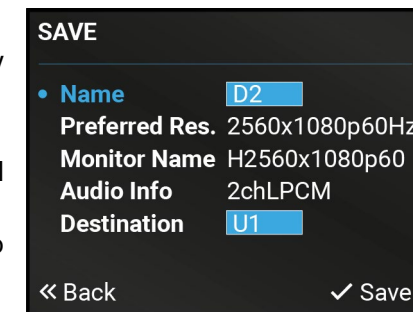

3.2.6. Preset Menu

The router can store presets and the following are stored in each slot: Input/output crosspoint state, muted/unmuted states. *#preset*

ATTENTION: When factory default settings are restored, presets are deleted.

Load a Preset

ATTENTION: The Preset loading has an effect on all ports, except the locked ones.

- Step 1.** Navigate to the **Presets / Load Preset** submenu and press the **knob**.
- Step 2.** The previously save presets are listed. Select the desired **memory slot** and press the **knob**. If any other preset had been saved previously, they would be also listed.
- Step 3.** Confirm your selection by pressing **Yes**.

Save a Preset

- Step 1.** Create the desired I/O layout.
- Step 2.** Navigate to the **Presets / Save Preset** submenu and press the **knob**.
- Step 3.** Select the desired **memory slot** and press the **knob**. If any other preset had been saved previously, they would be also listed. See the corresponding [Presets](#) section in the Lightware Device Controller (LDC) software.
- Step 4.** Confirm your selection by pressing **Yes**.

3.2.7. Health Menu

Health status overview of the matrix switcher and the most important information about the motherboard, control panel, power combiner and the I/O boards of the device.

Uptime

The time passed since the last powering up of the device.

Motherboard

Temperatures and fan speed status information are listed in the submenu.

Control Panel

The temperature of the control panel can be checked in the submenu.

Power Combiner

Fan speed, temperature and voltage status information about the Power Combiner 1 and 2 slots.

IO Boards

Temperature and voltage status information about the input (IB), output (OB) and auxiliary (AUX) boards.

HEALTH	
• Uptime	9 days 05:22:46
Motherboard	ok
Control Panel	ok
Power Combiner	ok
IO Boards	error
<< Back	

Legend

Status	Color	Description
ok	green	No active warning or error level log entry exists for the system or a device seated in the system.
warning	yellow	Active warning level log entry exists and no active error level log entry exists for the system or a device seated in the system.
error	red	Active error level log entry exists for the system or a device seated in the system.

4

Installation

The chapter is about the installation of the device and connecting to other appliances, presenting also the mounting options and further assembly steps.

- ▶ Mounting Options **33**
- ▶ Board Installation and Handling **34**
- ▶ Power Drawer Installation **35**
- ▶ Electrical Connections **36**
- ▶ Analog Audio Port Configuration **37**
- ▶ Connecting Steps **38**
- ▶ Powering On **39**

4.1. Mounting Options

WARNING! For the correct ventilation and to avoid overheating, ensure enough free space around the appliance. Do not cover the appliance, leave the ventilation holes free and never block or bypass the fans.

INFO: The dimensions of the frame can be found in the [Mechanical Drawings](#) section.

Fixing the Handles

Two handles can be mounted on the rack ears of the matrix switcher. The handles are supplied with the product.

Fasten the 2x 2 pcs M5 flat head fixing screws to fix the handles to the rack ears.

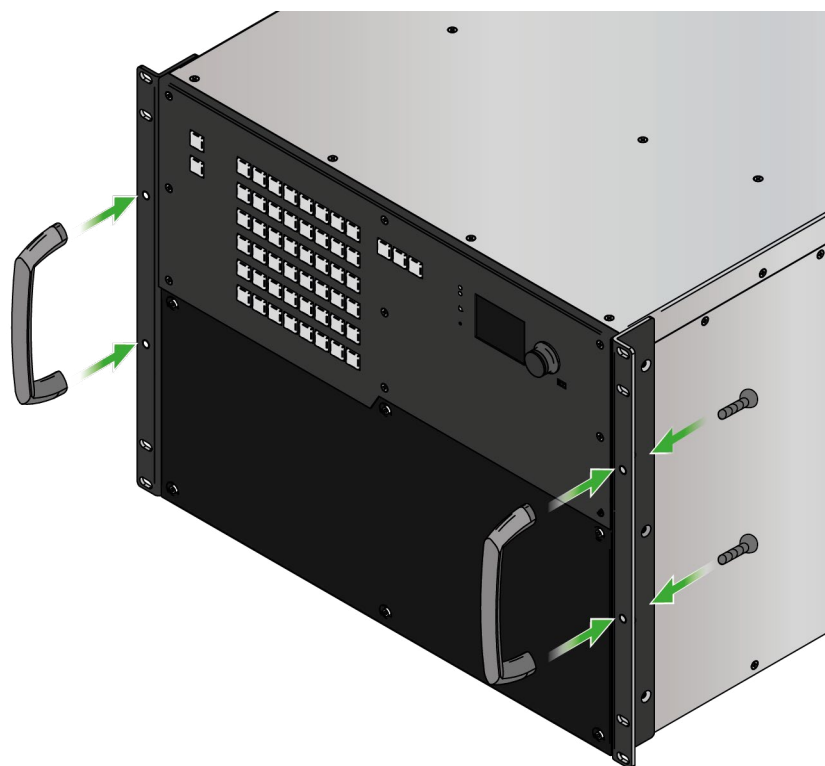

Fixing the handles to the rack ears of the matrix

Standard Rack Installation

Two rack ears are supplied with the product, which are fixed on left and right side as shown in the picture. The default position allows mounting the device as a standard rack unit installation.

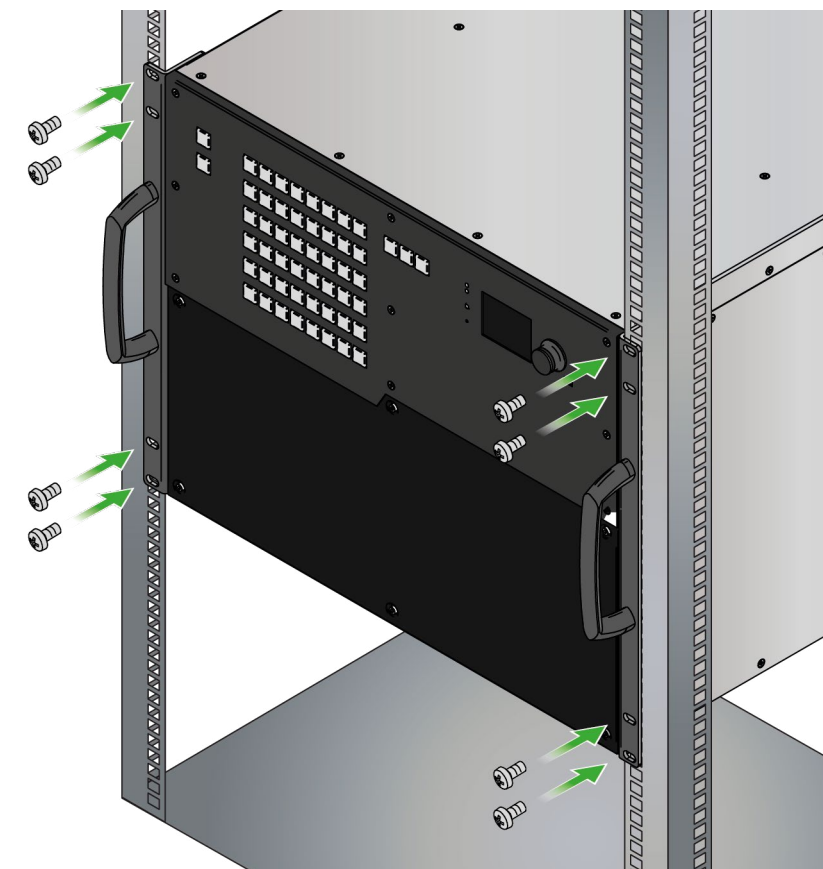

Standard rack cabinet installation

ATTENTION: Always use all the four screws for fixing the rack shelf ears to the rack rail. Choose properly sized screws for mounting. Keep a minimum of two threads left after the nut screw.

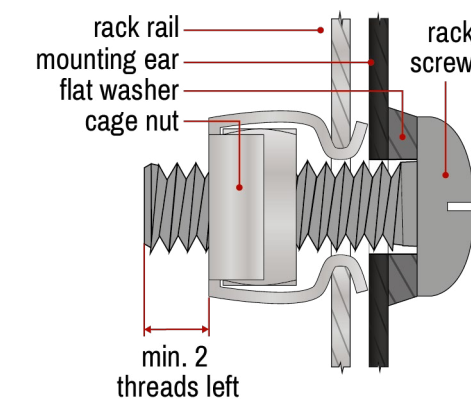

4.2. Board Installation and Handling

The I/O boards and the PSU drawers are hot-swappable. The matrix is not required to be powered off before removing / inserting a board.

4.2.1. The Layout of the Input/Output Board Slots

The following figure shows the layout and the numbering of the auxiliary (AUX, highlighted in yellow), input (IB, highlighted in purple) and output (OB, highlighted in green) board slots on the rear side of the matrix.

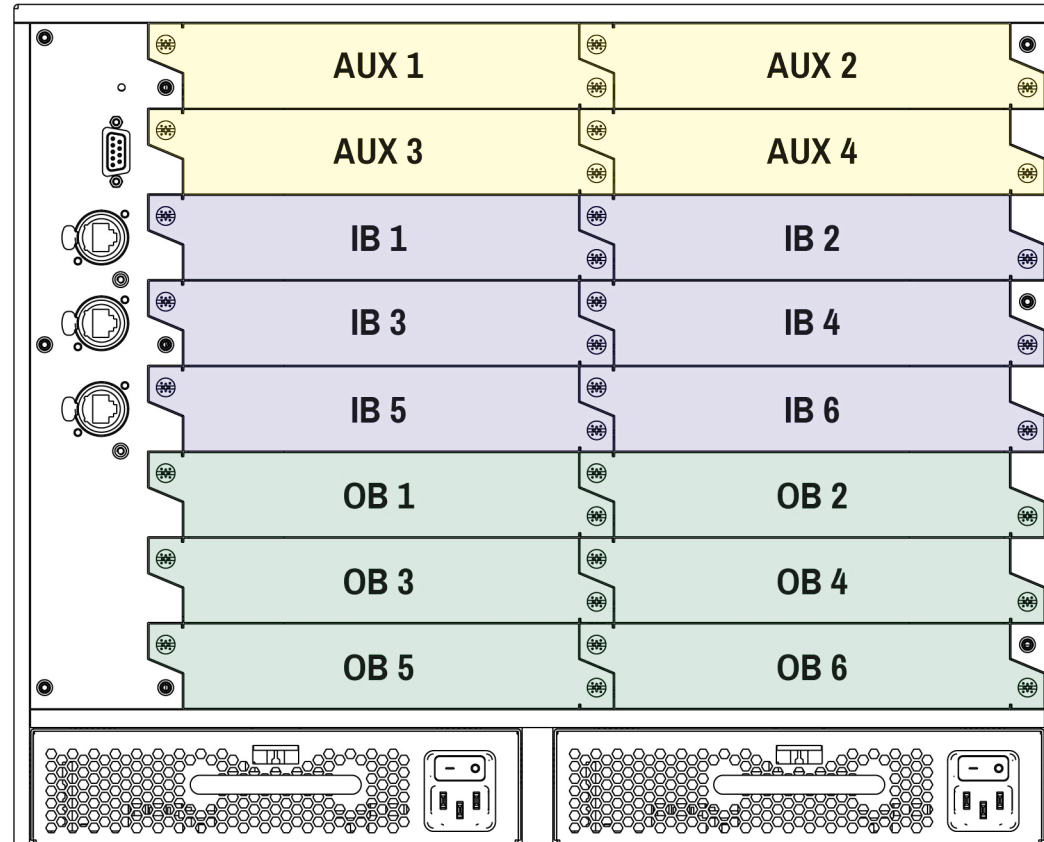

The layout of the I/O board slots

Auxiliary (AUX) Board Slots

The first four board slots are dedicated for the **auxiliary (AUX) boards**, which are also known as low-speed boards. These slots are able to accept AUX boards only.

The list of AUX boards:

- [MX2M-AUX-DANTE-32CH](#)
- [MX2M-AUX-8AUDIO](#)

Input (IB) Board Slots

The next six board slots are dedicated for the **input (IB) boards**, which are also known as high-speed boards. These slots are able to accept IB (high-speed) boards and AUX (low-speed) boards as well.

The list of the IB boards:

- [MX2M-4HDMI20-IB](#)
- [MX2M-DH-4DP12-IB](#)
- [MX2M-4OPTJ-IB](#)
- [MX2M-4TPX-IB](#)

Output (OB) Board Slots

The last six board slots are dedicated for the **output (OB) boards**, which are also known as high-speed boards. These slots are able to accept OB (high-speed) boards and AUX (low-speed) boards as well.

The list of the OB boards:

- [MX2M-4HDMI20-OB](#)
- [MX2M-4OPTJ-OB](#)
- [MX2M-4TPX-OB](#)

4.2.2. Installation of an I/O Board

WARNING! Please pay attention to the protection against electrostatic discharge when touching a board. Do not touch the electrical components on the board, as the electrostatic discharge may damage them.



ATTENTION: Please check the orientation of the slots. The AUX, IB and OB boards are assigned to dedicated board slots in the matrix.

INFO: The MX2M series I/O boards are hot-swappable devices. The matrix switcher is not required to be powered off before the board replacement procedure.

The steps of replacing an auxiliary, input or output board are the following:

- Step 1.** Loosen the **fixing screws** and remove the **blank cover** or the previously installed **board**.
- Step 2.** **Pull out the board** and put it in an ESD-safe bag. Take the board by touching the metal plate only, to prevent ESD-caused problems.
- Step 3.** **Place the board** into the desired empty slot. Place the edge of the panel carefully to the guide rails on the two sides of the slot. Gently push the board in until it stops, then press the plate at the indicated places at once. Thus, the connector of the board and the motherboard will be put together.

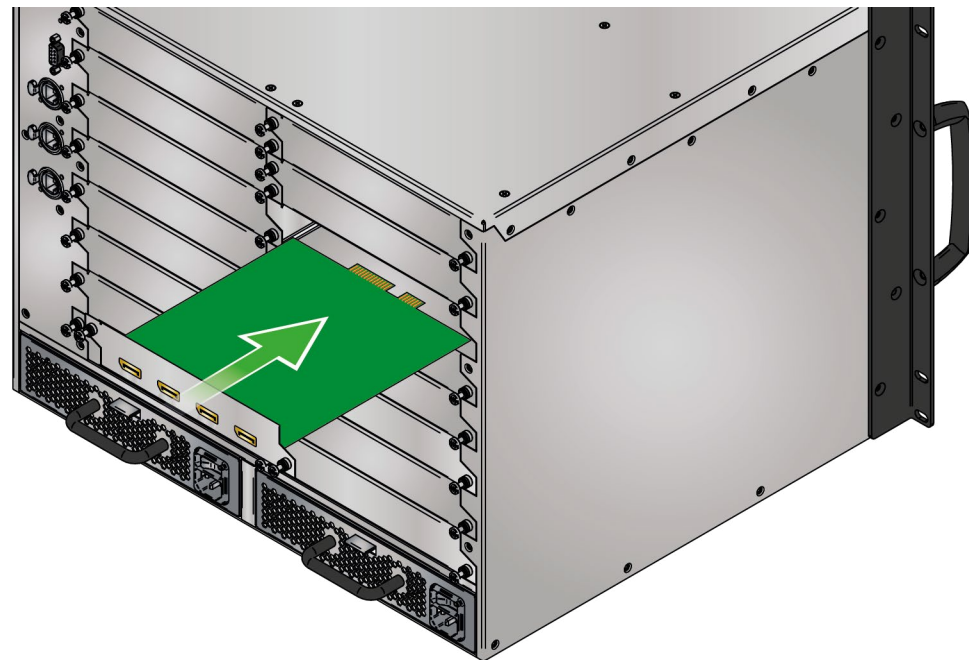

Step 4. **Tighten the two screws** by hand and fix them by a screwdriver with PZ1 head.

Step 5. Connect the necessary **cables** to the boards and switch on the matrix.

Step 6. Wait until the **booting procedure** of the board is completed.

INFO: If the firmware version of the installed I/O board is different than the firmware version of the matrix frame, it is being updated by the matrix automatically.

4.3. Power Drawer Installation

Two dedicated power drawer slots are available in the matrix frame for the [MX2M-PSU-500-F](#) and [MX2M-PSU-1250-FP](#) power supply units. The power drawer of the frame is hot-swappable, thus you do not have to switch off the matrix to replace or install a power drawer.

The Steps of the Power Drawer Replacement

Step 1. Push down the **fixing plate** on the power drawer.

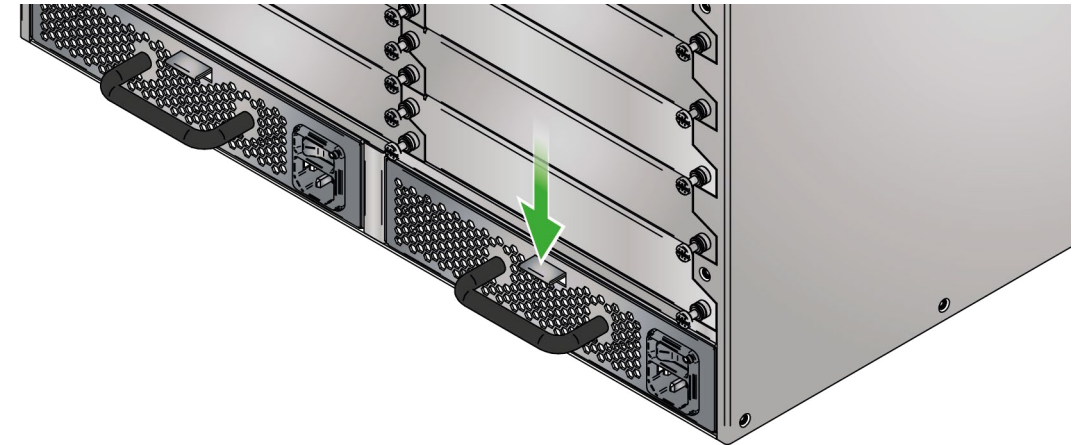

Step 2. Pull out the **power drawer** using the handle.

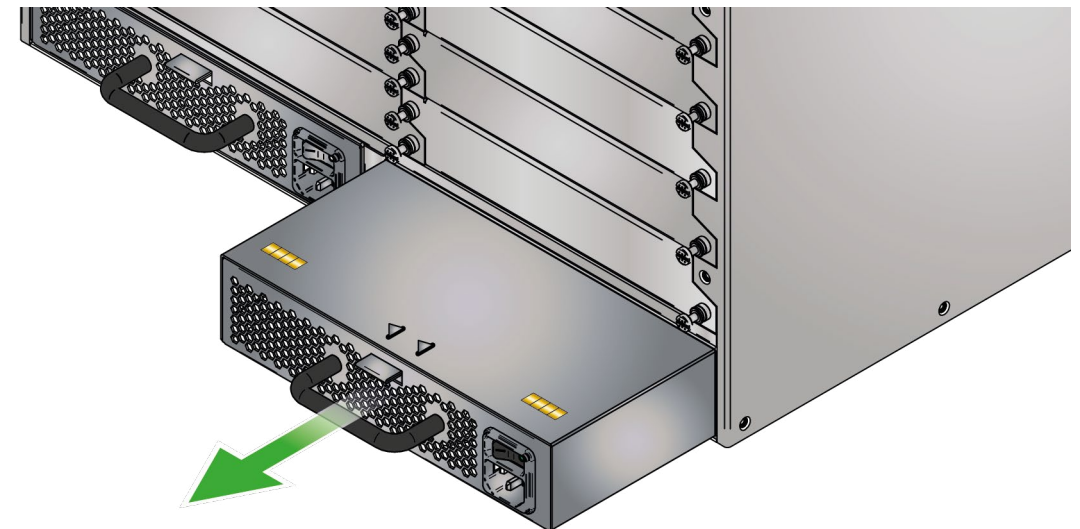

Step 3. Place the new power drawer to the power drawer slot and push it using the handle until the device connects to the motherboard of the frame.

ATTENTION: Make sure that the fixing plate is correctly in its place.

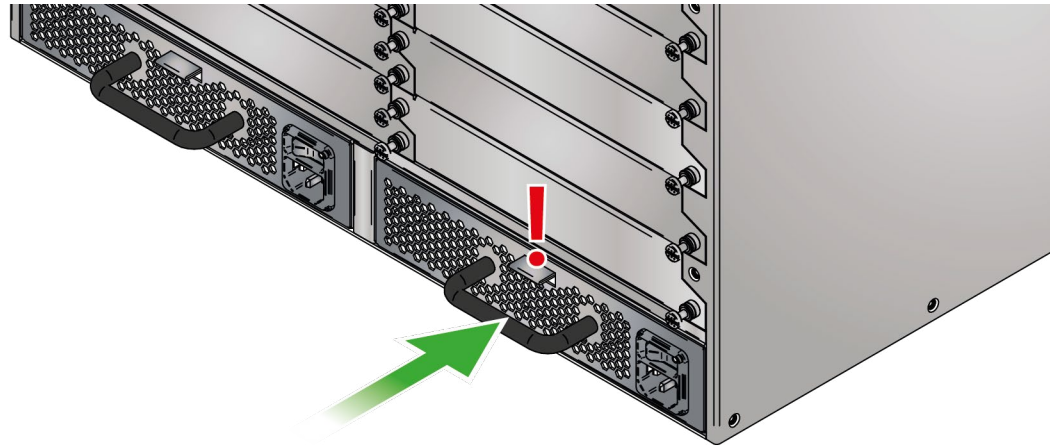

4.4. Electrical Connections

The following sections describe all possible electrical connections of the MX2M series frames, power drawers and I/O boards.

4.4.1. AC Power Connection

MX2M-PSU-500-F and MX2M-PSU-1250-FP power drawers contain standard IEC power connector and work with 100 to 240 Volts AC, 50 Hz or 60 Hz power sources.

Power drawer	Type	Number of power drawer slots in the frame	Output per power drawer (max)
MX2M-PSU-500-F	hot-swappable	2	500 W
MX2M-PSU-1250-FP	hot-swappable	2	1250 W



See the details about the powering on procedure in the [Powering On](#) section.

4.4.2. USB Mini-B Connector

MX2M series matrix frame provides standard USB 2.0 mini B-type connector for software control and firmware update purpose.



4.4.3. Ethernet Connectors

Neutrik etherCON Connectors

MX2M series matrix frame provides Neutrik etherCON RJ45 connectors for secure control purpose, LAN and user Ethernet access.

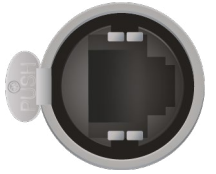

Standard RJ45 Connector

MX2M-AUX-DANTE-32CH and MX2M-4TPX series I/O boards provide standard RJ45 connectors. Always use high quality Ethernet cable.

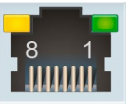

Wiring of LAN Cables

Lightware recommends the termination of LAN cables on the basis of TIA/EIA T 568 A or TIA/EIA T 568 B standards.

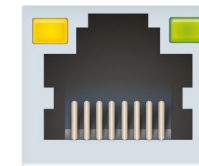

Pin	TIA/EIA T568A	TIA/EIA T568B
1	white/green	white/orange
2	green	orange
3	white/orange	white/green
4	blue	blue
5	white/blue	white/blue
6	orange	green
7	white/brown	white/brown
8	brown	brown

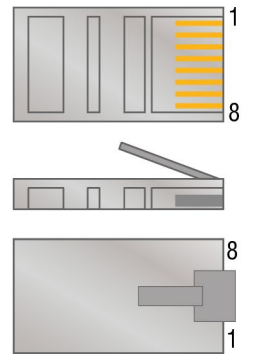

Wiring of LAN cables by types

WARNING! Never connect a non-assembled CATx cable to the port while the unit is powered, it may damage the device.

4.4.4. RS-232 Connector

The matrix frame has a standard 9 pin D-sub female (DE9F) miniature receptacle for device control purpose.



Pin nr.	RS-232 straight pin-out	RS-232 cross pin-out
1	Not connected	Not connected
2	TX data transmit (out)	RX data receive (in)
3	RX data receive (in)	TX data transmit (out)
4	DTR (Internally connected to Pin 6)	DTR (Internally connected to Pin 6)
5	GND signal ground (shield)	GND signal ground (shield)
6	DSR (Internally connected to Pin 4)	DSR (Internally connected to Pin 4)
7	RTS (Internally connected to Pin 8)	RTS (Internally connected to Pin 8)
8	CTS (Internally connected to Pin 7)	CTS (Internally connected to Pin 7)
9	Not connected	Not connected

Wiring methods of the DE9F D-sub connector

4.4.5. Symmetrical Analog Stereo Audio Connector

MX2M-AUX-8AUDIO auxiliary board provides 5-pole Phoenix connectors, which are used for balanced analog audio (line in/out). Unbalanced audio signals can be connected as well. For asymmetrical output, connect only + and ground. For asymmetrical input, connect + and ground to the source and connect – to the ground.

Compatible Plug Type

Phoenix® Combicon series (3.5mm pitch), type: MC 1.5/5-ST-3.5.



Pin nr.	Signal
1	Left+
2	Left-
3	Ground
4	Right-
5	Right+

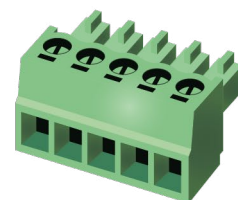

5-pole Phoenix connector pin assignments

See more information about the most common audio cable wiring modes in [Cable Wiring Guide](#) section.

You can find more information about audio embedding and de-embedding functions in the [Audio Layer](#) section.

4.4.6. HDMI Connector

MX2M-4HDMI20 series I/O boards provide standard 19-pole HDMI connectors for inputs and outputs with HDMI 2.0 support. Always use high quality HDMI cables for connecting sources and displays.



INFO: HDMI input and output connectors have **flange** mounting option.

You can find more information about the video related functions in the [Video Layer](#) section.

4.4.7. DisplayPort Connector

MX2M-DH-4DP12-IB input board provides standard 20-pole DisplayPort connectors for inputs with DisplayPort 1.2 support. Always use high quality DP cables for connecting devices.



You can find more information about the video related functions in the [Video Layer](#) section.

4.4.8. SC Fiber Optical Connector

MX2M-4OPTJ series I/O boards provide multimode SC simplex fiber optical input and output connectors. The connectors are compatible with the HDMI20-OPTJ-90 series fiber optical extenders.



You can find more information about the video related functions in the [Video Layer](#) section.

Maximum cable distances can be found in the [Maximum Cable Distances](#) section.

4.5. Analog Audio Port Configuration

The analog audio ports of the MX2M-AUX-8AUDIO board can be configured as input and output by the user. The port configuration can be done by placing a **jumper** to the right pins.

WARNING! Always apply ESD-protection during the port configuration. Electric discharge may harm the electric parts of the board.

Steps of the Configuration

- Step 1.** Release the two fixing screws of the board and pull it out.
- Step 2.** Find the 3-pole port configuration pin set behind the 5-pole Phoenix connector.
- Step 3.** Place the jumper to re-configure the port as follows:

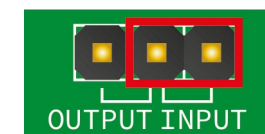

The port is configured as an input

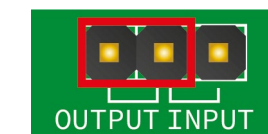

The port is configured as an output

- Step 4.** Place the board into the desired slot.
- Step 5.** Tighten the two screws by hand and fix them by a screwdriver with PZ1 head.
- Step 6.** Connect the necessary cables to the boards and switch on the matrix.
- Step 7.** Wait until the booting procedure of the board is completed.

4.6. Connecting Steps

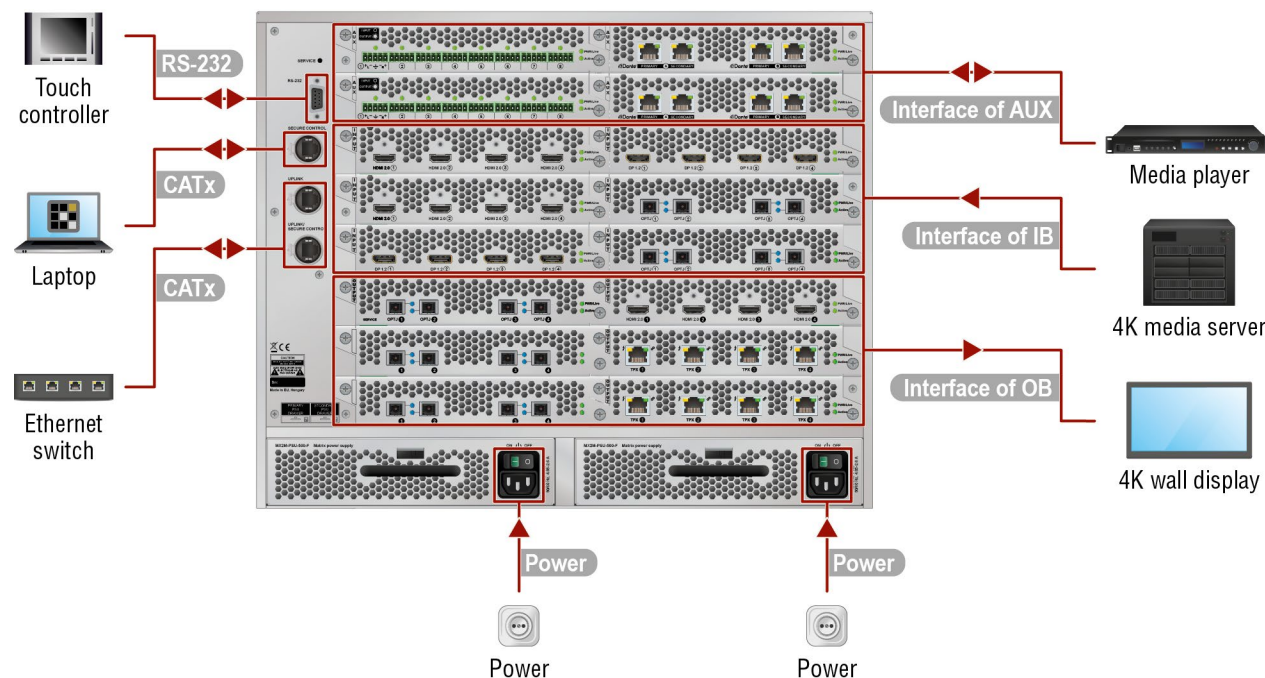

RS-232 Optionally for RS-232 control: connect a controller device (e.g. touch panel) to the **RS-232** port.

CATx Connect the matrix switcher to a controller device (e.g. laptop) via the **Secure Control** port over a CATx cable. The port supports 1 GbE data transmission.

CATx Connect the matrix switcher to a LAN via the **Uplink** and **Uplink / Secure Control** ports over CATx cables. The Uplink port is for user Ethernet access; the Uplink / Secure control port is for user Ethernet access or control the matrix switcher. Both ports support 1 GbE data transmission.

Power Connect the power cords to the AC power sockets and to the matrix.

If the matrix is purchased with only one power drawer, connect the power cord to the AC power socket and to the matrix. See more details about it in the [Licensing](#) section.

The matrix has redundant PSU drawers, which can be switched on and off without interrupting the video transmission. Using one or both of the PSU drawers at the same time is also possible.

The double power drawer allows connecting them to two different AC power lines to ensure the continuous power for the matrix.

See more details about the powering on procedure in the [Powering On](#) section.

Interface of AUX

Connect the source / sink devices (e.g. media player) to the ports of the MX2M-AUX series boards via the interface of the board. See the connection possibilities grouped by I/O board variants:

- **MX2M-AUX-8AUDIO** - Connect audio source devices to the audio input connectors and audio sink devices to the audio output connectors. The input/output function of the ports can be modified anytime by the user, see the details in the [Analog Audio Port Configuration](#) section. See the wiring guide for the Phoenix 5-pole connector in the [Cable Wiring Guide](#) section.
- **MX2M-AUX-DANTE-32CH** - Connect the Dante® or AES67 audio source and sink devices to the Primary connectors and the redundant connections to the Secondary connectors via Ethernet cables. The recommended cable type for 1 GbE signal transmission is CAT5e or CAT7e up to 100 m.

Interface of IB

Connect the AV source devices (e.g. 4K media server) to the ports of the MX2M-IB series boards via the interface of the board (DisplayPort, HDMI, fiber optical, etc). See the connection possibilities grouped by I/O board variants:

- **MX2M-4HDMI20-IB** - Connect the source devices using the **HDMI 2.0** ports by HDMI cables.
- **MX2M-DH-4DP12-IB** - Connect the source devices using the **DP 1.2** ports by DisplayPort cables.
- **MX2M-4OPTJ-IB** - Connect a single multimode fiber optical cable between the **OPTJ** SC connectors and the **HDMI20-OPTJ-TX90** extenders. See the details about the maximum fiber cable extensions in the [Maximum Cable Distances](#) section.
- **MX2M-4TPX-IB** - Connect a CATx cable between the **TPX** RJ45 connectors and the **HDMI-TPX** series transmitter. See the details about the maximum CATx cable extensions in the [Maximum Cable Distances](#) section.

Interface of OB

Connect the AV sink devices to the ports (e.g. 4K wall display) of the MX2M-OB series boards via the interface of the board (HDMI, fiber optical, etc). See the connection possibilities grouped by I/O board variants:

- **MX2M-4HDMI20-OB** - Connect the sink devices using the **HDMI 2.0** ports by HDMI cables.
- **MX2M-4OPTJ-OB** - Connect a single multimode fiber optical cable between the **OPTJ** SC connectors and the **HDMI20-OPTJ-RX90** extenders. See the details about the maximum fiber cable extensions in the [Maximum Cable Distances](#) section.
- **MX2M-4TPX-OB** - Connect a CATx cable between the **TPX** RJ45 connectors and the **HDMI-TPX** series receiver. See the details about the maximum CATx cable extensions in the [Maximum Cable Distances](#) section.

4.7. Powering On

Connect the power cords to AC input of the power drawers ([MX2M-PSU-500-F](#) / [MX2M-PSU-1250-FP](#)).

INFO: The router has an internal emergency memory that stores all current settings and tie configurations. This memory is independent from presets and invisible to the user. This built-in feature helps the system to be ready immediately in case of power failure or accidental power down.



Powering On Procedure

After switching the power switch to the **ON** position, the router starts up. If the switch is in the **ON** position, then the matrix starts up immediately when the power cord is connected to the AC source. During the initial self-test and loading of the latest settings, **The matrix is about to start** appears on the LCD screen and the router reloads its last configuration.

INFO: After switching ON, the router reloads the latest settings that were used before it was switched off. The router has an internal emergency memory that stores all current settings and tie configurations.

Redundant Power Supplies

The matrix has redundant power drawers which can be switched on and off without interrupting the video transmission. Using one or both of the power drawers at the same time is also possible.

The double power drawer allows connecting them to two different AC power lines to ensure the continuous power for the matrix. The power drawers are hot-swappable.

5

Hybrid Modular Matrix Concept

The following chapter describes the features of the MX2M series frame and I/O boards with few real-life examples. The topics that are described:

▶ Video Layer	41
▶ Audio Layer	43
▶ Consumer Electronics Control (CEC) Interface	47
▶ Signal Extension Methods	47
▶ Ethernet Layer	49
▶ Licensing	49
▶ Further Built-in Features	50
▶ Software Control Modes	50

5.1. Video Layer

5.1.1. Port Diagram

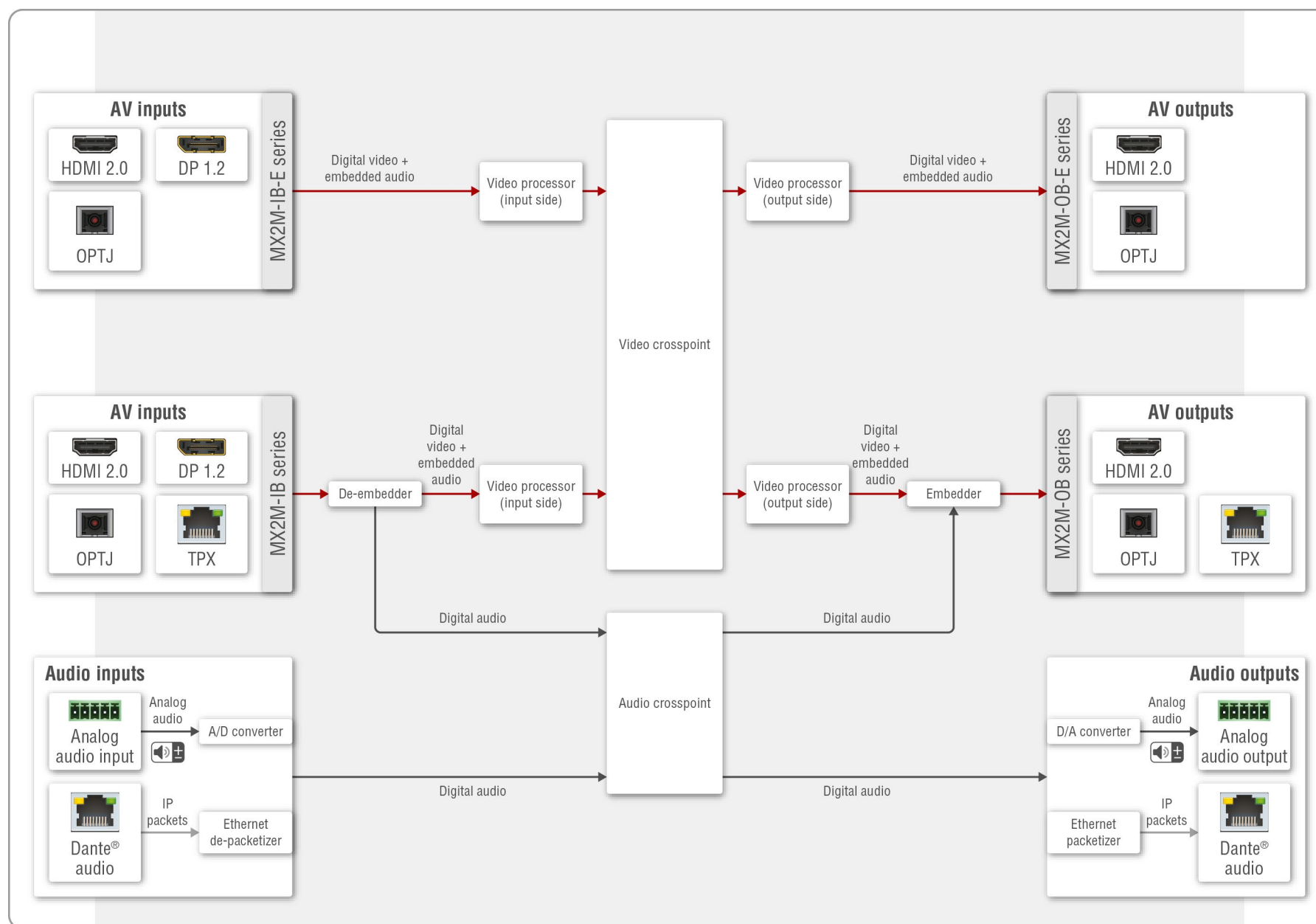

AV port diagram of the MX2M series matrix switcher

Description

The MX2M matrix receives video streams with the embedded audio signal via various types of multimedia ports, which depend on the installed I/O boards. The video streams can be switched to any destination port in the video crosspoint sized up to 24x24.

The video and audio layers are independent of each other. The audio signal is copied to the Audio layer from the stream and routed to the audio crosspoint, where it can be switched to the AV outputs (HDMI, fiber optical or TPX) and the audio outputs (analog audio or Dante network) as well.

Audio input signals can be received via the analog audio input and Dante audio network. The audio streams can be switched to the audio outputs (analog audio or Dante network) or can be embedded into the output streams (HDMI, fiber optical or TPX).

See more details about the audio layer and the available options in the [Audio Layer](#) section.

There are video processors on the input and output sides as well. Available functions are the following, grouped by AV interfaces:

- **HDMI 2.0**
 - **Input side:** no video processing can be applied.
 - **Output side:** the sampling pattern can be converted from 4:4:4 to 4:2:2.

ATTENTION: The MX2M-4HDMI20-OB output board accepts video signals in 8, 10 and 12 bit color depth, but the sampling pattern conversion is always made in 8 bit.

- **DP 1.2**
 - **Input side:** the sampling pattern can be converted from 4:4:4 to 4:2:2 or 4:2:0 and the color depth can be converted 12 bit to 8 bit per channel if the signal bandwidth is greater than 18 Gbit/s.
- **OPTJ**
 - **Input side:** no video processing can be applied.
 - **Output side:** the sampling pattern can be converted from 4:4:4 to 4:2:2.
- **TPX**
 - **Input side:** no video processing can be applied.
 - **Output side:** the sampling pattern can be converted from 4:4:4 to 4:2:2.

INFO: The available audio and video interfaces depend on the installed I/O boards.

5.1.2. Video Signal Transmission - Example

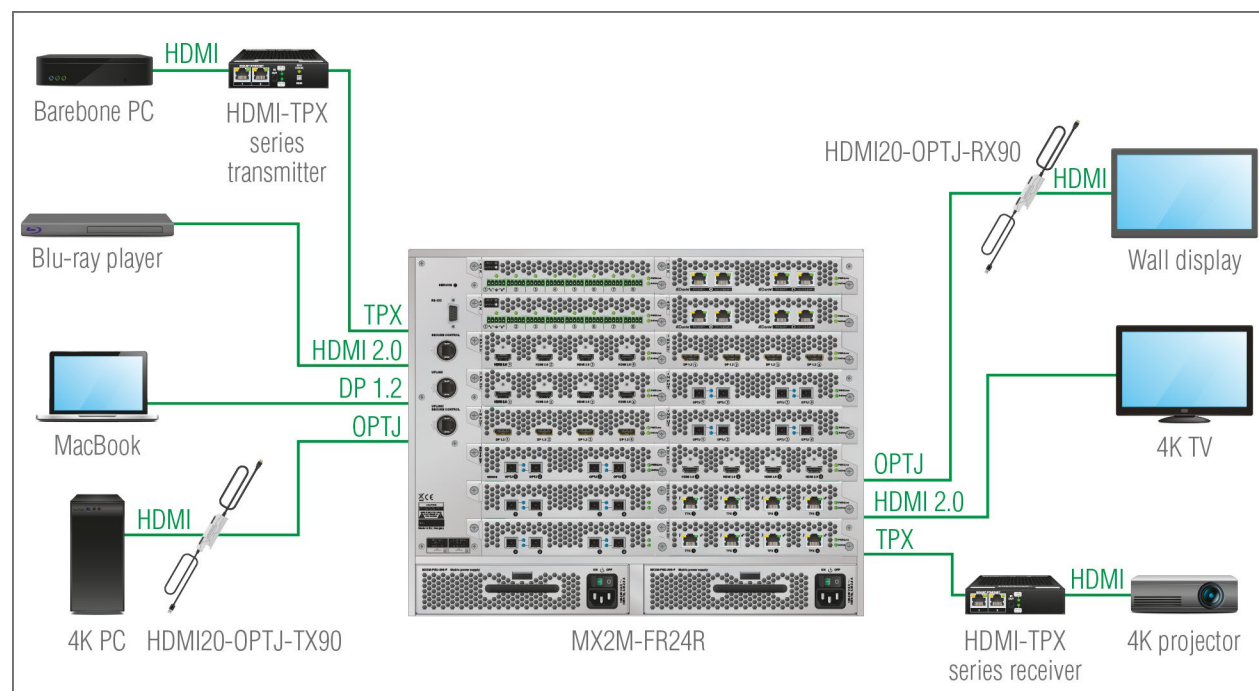

The Concept

The matrix frame is installed with seven different type of I/O boards:

	I/O board	Connection interface	Signal direction	Connected device
IB	MX2M-4TPX-IB	TPX (SDVoE)	Input	Barebone PC
	MX2M-4HDMI20-IB	HDMI	Input	Blu-ray player
	MX2M-DH-4DP12-IB	DisplayPort	Input	MacBook
	MX2M-4OPTJ-IB	Multimode fiber optical	Input	4K PC over a HDMI20-OPTJ-TX90 fiber optical transmitter
OB	MX2M-4OPTJ-OB	Multimode fiber optical	Output	Wall display over a HDMI20-OPTJ-RX90 fiber optical receiver
	MX2M-4HDMI20-OB	HDMI	Output	4K TV
	MX2M-4TPX-OB	TPX (SDVoE)	Output	4K projector over a HDMI-TPX series receiver

The video signals of the input boards can be routed to any port of the output boards. The video crosspoint settings can be set using four different methods:

- **Front panel buttons** - see the details in the [Switching Operations](#) section;
- **Built-in website / Lightware Device Controller (LDC) software** - see the details in the [Crosspoint Menu](#) section;
- **LW3 protocol commands** - see the details in the [Video Switching and Crosspoint Settings](#) section.

Available Video Related Settings

The following settings and options are available for the video stream input:

MX2M-4HDMI20-IB and MX2M-4OPTJ-IB boards:

- Input port HDCP capability setting

MX2M-DH-4DP12-IB board:

- Sampling pattern conversion to 4:2:2 or 4:2:0
- Color depth conversion to 8 bit per channel
- Input port HDCP capability setting

INFO: When the DisplayPort source sends RGB 4:4:4 10-bit HDR signal, then it will be converted to 8-bit HDMI signal, **if the AV signal exceeds the bandwidth limitation of the HDMI 2.0 standard**, else the original content is transmitted. Enabling YCbCr 4:2:2 conversion will save bandwidth by chroma subsampling and preserve the color depth.

The following settings and options are available for the video stream output:

- Sampling pattern conversion to 4:2:2
- Output port HDCP mode setting
- Audio stream embedding setting

5.2. Audio Layer

5.2.1. Overview

The embedded digital audio of the input video stream is copied to the Audio layer and it can be selected to the analog audio interface as well.

On the output side the audio signal can be selected for the output video stream: the original embedded audio is transmitted together with the video or it is changed to another audio (even analog audio) signal that can be selected in the audio crosspoint table.

5.2.2. Digital Audio Interface

Inputs

The matrix is able to receive embedded audio streams via the digital video interfaces:

- Embedded HDMI audio over the MX2M-4HDMI20-IB / MX2M-4OPTJ-IB / MX2M-4TPX/IB boards;
- Embedded DisplayPort audio over the MX2M-DH-4DP12-IB board.

INFO: The audio signal can be one that the **HDMI 2.0 standard supports**.

Outputs

The matrix is able to transmit audio streams from the Audio layer as audio embedded in the output video signal, provided that the signal on the audio layer qualifies for embedding.

The digital video signals can be:

- LPCM audio format;
- Low bitrate (<6,144 Mbit/s) audio format.

INFO: The audio signal can be **2-channel PCM up to 48kHz** or **compressed (non-HBR) audio**.

Crosspoint Settings

The audio layer is independent of the video layer. Thus, any audio input signal can be selected to any output. However, there are limitations on how the respective output can treat the signal:

- Only LPCM audio signals routed from the Audio layer can be selected to the audio outputs of the MX2M-AUX-8AUDIO or MX2M-AUX-DANTE-32CH auxiliary boards;
- Only LPCM and compressed (<6,144 Mbit/s) audio signals routed from the Audio layer can be selected to the outputs of the MX2M series video output boards.

INFO: In case of LPCM audio, at most two channels can be selected for embedding into the output HDMI stream.

5.2.3. Analog Audio Interface

DIFFERENCE: The analog audio interface is available only when the **MX2M-AUX-8AUDIO** auxiliary board is installed.

Configurable Ports

The MX2M-AUX-8AUDIO board is built with 8 pieces of 5-pole Phoenix® analog audio ports. Each port can be configured as input or output. See the details about the steps of the configuration in the [Analog Audio Port Configuration](#) section.

Input Side

The matrix is able to receive analog audio streams via the analog audio interface. The received audio stream is converted to digital audio signal and can be embedded to any digital video signal on the output side.

INFO: The analog audio signal is converted to **LPCM with a sampling frequency of 48kHz**.

The following audio settings are available for the analog audio input signal:

- **Volume** adjusting
- **Balance** setting
- **Gain** setting

The audio settings are available in the **Built-in website / Lightware Device Controller (LDC)** software (details in the [Analog Audio Input Port Properties](#) section) and using **LW3 protocol commands** (details in the [Analog Audio Port Properties](#) section).

Output Side

The matrix is able to transmit analog audio streams via the analog audio interface. The transmitted signal can originate from an analog audio interface, can be de-embedded digital audio signal from any digital video interfaces, or it can come from the MX2M-AUX-DANTE-32CH board.

INFO: The analog audio signal is converted to **LPCM with a sampling frequency of 48kHz** on the input side.

The following audio settings are available for the analog audio output signal:

- **Volume** adjustment
- **Balance** setting

The audio settings are available in the **Built-in website / Lightware Device Controller (LDC)** software (details in the [Analog Audio Output Port Properties](#) section) and using **LW3 protocol commands** (details in the [Analog Audio Port Properties](#) section).

5.2.4. Dante® Audio Interface

DIFFERENCE: The Dante/AES67 audio interface is available only when a **MX2M-AUX-DANTE-32CH** board is installed in the matrix frame.

Digital AoE (Audio over Ethernet) signals can be received and transmitted over the Dante audio interface. The input signals can be routed to any interface within the matrix, for example it can be embedded into the HDMI output signal or transmitted as analog audio. The Dante output signal can be sourced from any other input signal type, for example it can be de-embedded from the HDMI signal or can be received from a microphone as analog audio input.

Supported Audio

Signal type	Input Ports	Output Ports
PCM 16	✓	✗
PCM 24	✓	✓
Compressed DTS/Dolby	✗	✗

ATTENTION: The supported sample rates are **44.1, 48, 88.2 and 96 kHz**.

Important Notes

- It is essential to have the **right QoS settings** in the network switch where the Dante® audio is connected to. See the details in the [Switch Setup for Dante® Audio Signal Transmission](#) section.
- The **AES67 mode** is supported by the MX2M-AUX-DANTE-32CH auxiliary board, which can be set in the Dante® Controller software.
- Multichannel or encoded audio** format cannot be de-embedded. In this case, no audio is sent to the Dante® network.

Dante® is a registered trademark of Audinate Pty Ltd.

Settings and Signal Routing

Dante Controller software

All these features are available in the Dante Controller software, which can be downloaded from the manufacturer's web page: <https://www.getdante.com/products/software-essentials/>

Device Settings

The discovered Dante-compatible devices are displayed with middle-blue color. Double-click on the name to open the device settings. The channels can be renamed in the LDC application (see the details in [Dante® Audio Input Port Properties](#) and [Dante® Audio Output Port Properties](#) sections) and via LW3 protocol command (see the details in [Renaming the Channel Label](#) section).

Dante/AES67 Signal Routing

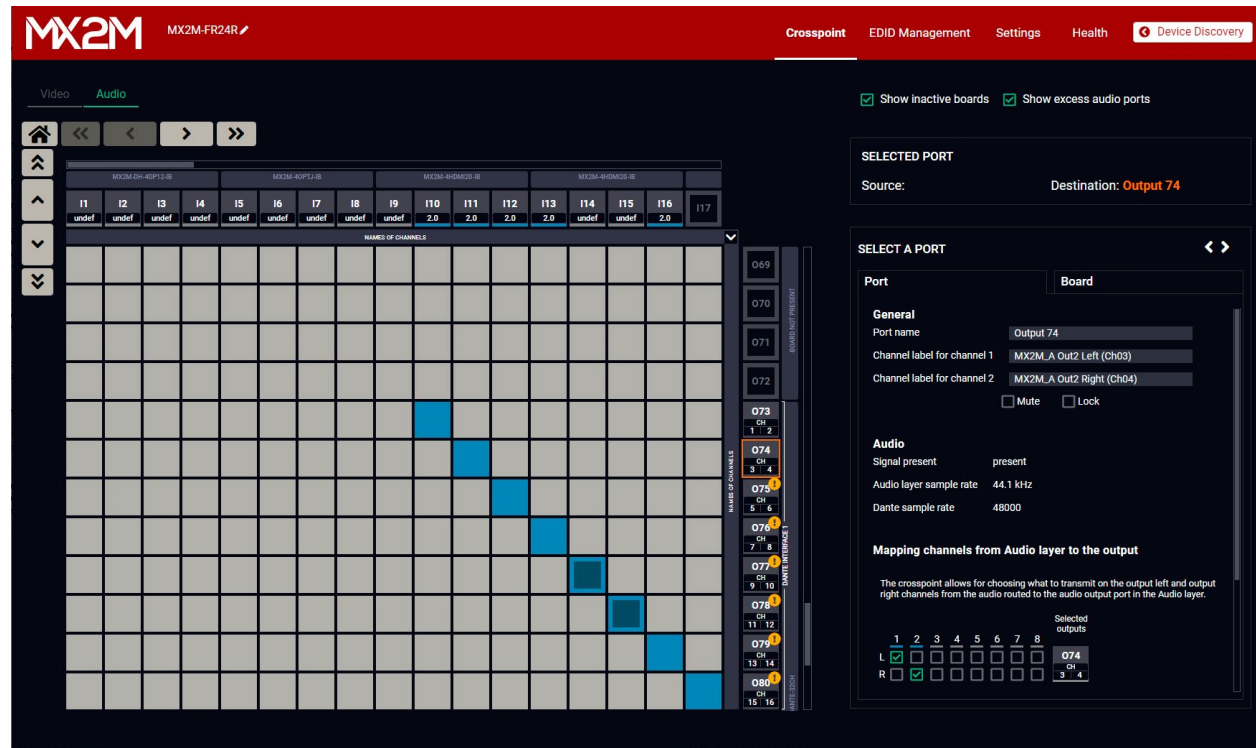

Crosspoint menu - Audio layer in the Lightware Device Controller software

Dante or AES67 audio signals can be routed to any other interface types within the matrix switcher. The Dante source signal can be embedded to the HDMI signal or transmitted to an analog audio sink device. De-embedded DisplayPort audio can also be transmitted as Dante audio to a network audio sink device.

The Dante audio settings are available in the **Built-in website / Lightware Device Controller (LDC) software** (details in the [Dante® Audio Input Port Properties](#) and [Dante® Audio Output Port Properties](#) sections) and using **LW3 protocol commands** (details in the [Dante® Audio Settings](#) section).

5.2.5. Multichannel Routing to the Outputs

This section explains how to be transmitted a multichannel audio signal to the audio output ports of the matrix.

Example

In our example an 8-channel LPCM audio signal is required to transmit over the MX2M-AUX-DANTE-32CH auxiliary board of the matrix. The figure below shows the method that can be used for transmitting the 8 channels to the output ports.

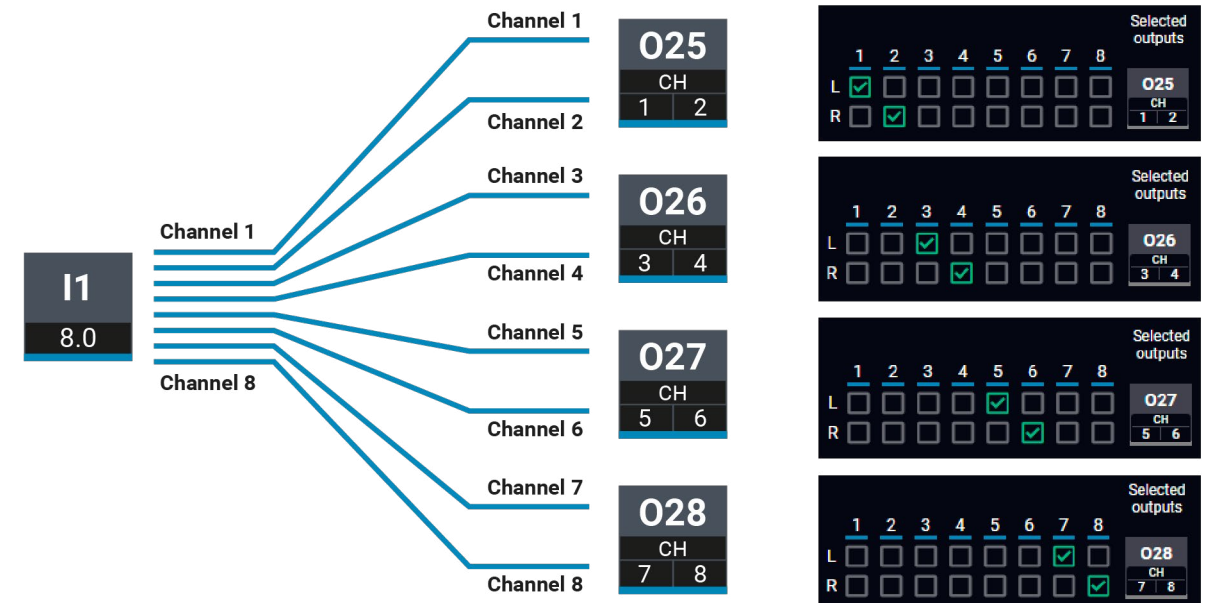

Example for multichannel audio signal routing

Required Settings

- Step 1.** Switch the input port (I1) to four output ports (O25; O26; O27; O28) in the crosspoint table. It can be done using one of the following methods:
 - via **Lightware Device Controller (LDC) software** - see the details in the [Audio Layer](#) section.
 - via **LW3 protocol commands** - see the details in the [Switching an Input to an Output](#) section.
- Step 2.** Set the **channel mapping** to select the desired channels for the output ports. Ensure that all input channels are routed to different output channels. The channel mapping can be done using one of the following methods:
 - via **Lightware Device Controller (LDC) software** - navigate to the Port properties panel of each selected output port by clicking on the output port icon and complete the channel mapping settings. See the details in the [Dante® Audio Output Port Properties](#) section.
 - via **LW3 protocol commands** - see the details in the [Channel Mapping](#) section.

5.2.6. Audio Signal Transmission - Example

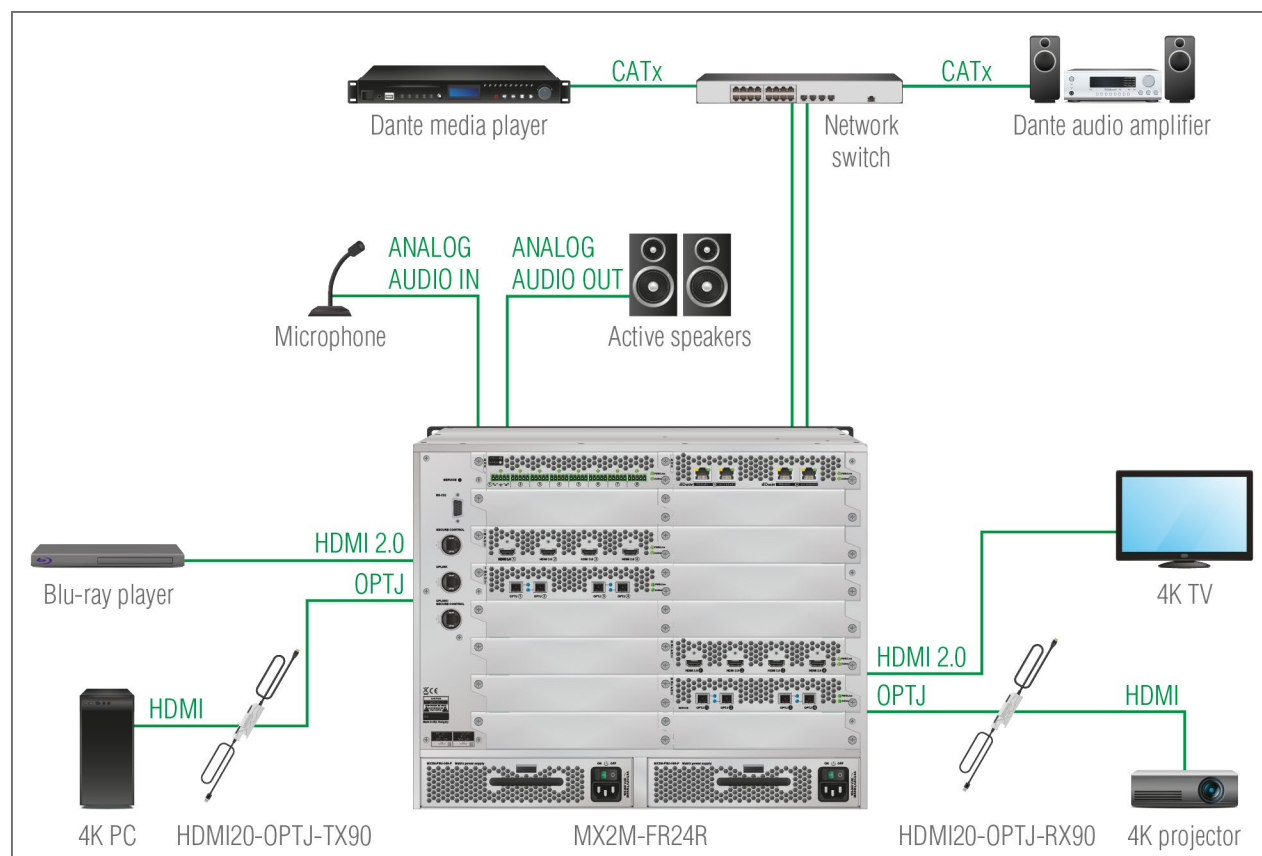

The Concept

The matrix frame is installed with different types of I/O boards:

	I/O board	Connection interface	Signal direction	Connected device
AUX	MX2M-AUX-8AUDIO	Analog audio cable with 5-pole Phoenix connector	Input	Microphone
			Output	Active speakers
	MX2M-AUX-DANTE-32CH	CATx	Input	Dante media player over a network switch
			Output	Dante audio amplifier over a network switch
IB	MX2M-4HDMI20-IB	HDMI	Input	Blu-ray player
	MX2M-4OPTJ-IB	Multimode fiber optical	Input	4K PC over a HDMI20-OPTJ-TX90 fiber optical transmitter
OB	MX2M-4HDMI20-OB	HDMI	Output	4K TV
	MX2M-4OPTJ-OB	Multimode fiber optical	Output	4K projector over a HDMI20-OPTJ-RX90 fiber optical receiver

Inputs

The matrix can receive audio signals from three types of sources:

- **Analog audio** from the microphone - it is converted to 2-channel LPCM signal and routed to the Audio layer;
- **Digital embedded HDMI audio** from the Blu-ray player - the signal is de-embedded and copied to the Audio layer.
- **AoE (Audio over Ethernet) audio signal from the Dante media player via the network** - the digital audio signal is copied to the Audio layer.

Outputs

On the output side, the matrix can transmit three types of audio signals:

- **Analog audio signal** to the active speakers - the transmitted audio signal can be 2-channel LPCM only. As the selected signal can include more than two audio channels, the user can select the two channels to be transmitted on the analog audio interface.
- **Digital embedded HDMI audio** to the 4K TV - the embedded audio signal can be 2-channel LPCM or compressed (non-HBR) audio signal only. There are two possibilities in case of audio signal embedding:
 - If the selected signal is of type LPCM, the user can select the two channels to be transmitted.
 - If the selected signal is compressed (non-HBR) audio, it can be embedded into the video stream without any further action.
- **AoE (Audio over Ethernet) audio signal to the Dante audio amplifier via the network** - the transmitted audio signal can be PCM 16 and PCM 24 audio signals up to 16 channels. If the selected signal includes more than two audio channels, the user can select the two channels to be transmitted.

See more details about the related settings in the **Lightware Device Controller (LDC)** software in the [Audio Port Properties Windows](#) section.

5.3. Consumer Electronics Control (CEC) Interface

Consumer Electronics Control (CEC) is a bi-directional communication, defined in the HDMI standard. This feature is for remote control of the source and sink devices in the AV system.

MX2M-4HDMI20 and MX2M-4OPTJ series I/O boards are able to send and receive CEC commands, from the input ports towards the source, and from output port towards the sink. For more information about sending CEC messages, see the [CEC Controller](#) (LDC) and the [Sending CEC Commands](#) (LW3 protocol commands) sections.

ATTENTION: CEC has a dedicated pin in the HDMI connector. DVI connector does not contain this pin, so the CEC transmission brakes when HDMI-DVI connector or adapter is in the signal route.

CEC Application Example

The matrix is able to send CEC commands over the HDMI and fiber optical ports to the sink and the source devices as well.

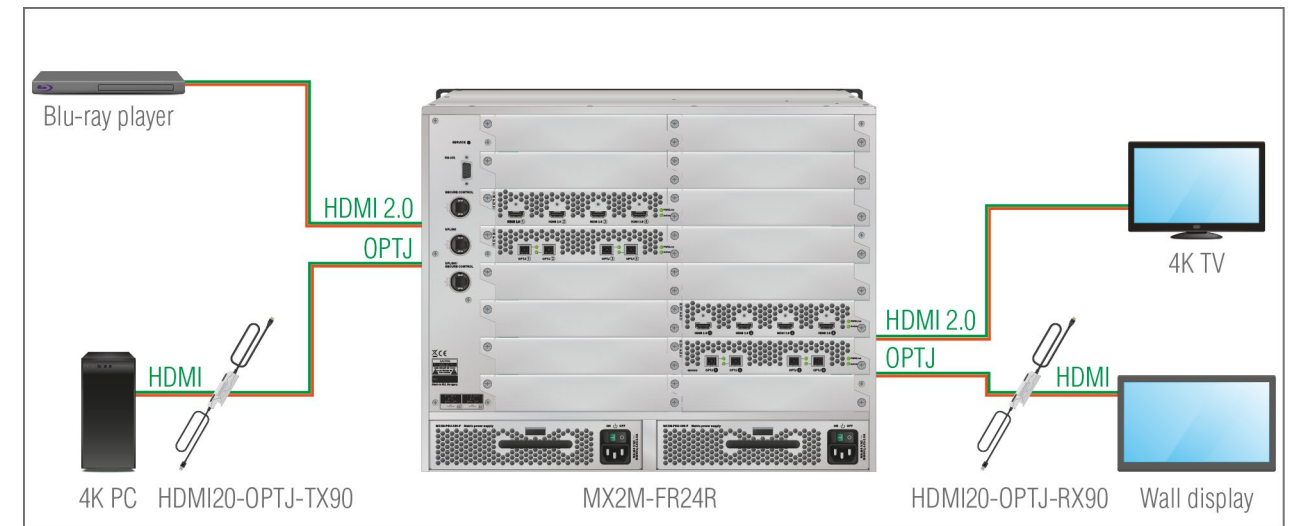

5.4. Signal Extension Methods

MX2M series matrix switchers offer several ways to extend the AV signal ranges. Beyond the traditional cable types (HDMI, DisplayPort), where the MX2M series I/O board uses signal compensation to extend the applicable cable lengths, the modular matrix offers more I/O boards that are able to extend the cable length to up to 1200 meters.

Featured MX2M series I/O Boards:

- **MX2M-AUX-DANTE-32CH** - Dante / AES67 audio interface that is able to make connection between the auxiliary board and a network switch or Dante / AES67 capable source or sink device using CATx cables - see more details in the [Audio Signal Extension over Dante Interface](#) section.
- **MX2M-4OPTJ-IB / MX2M-4OPTJ-OB** - Audio+video signal extension over a multimode fiber optical cable, up to 4K60 resolution. MX2M-4OPTJ series boards are fully compatible with the HDMI20-OPTJ-90 series optical extenders - see more details in the [AV Signal Extension over Fiber Optical Cable](#) section.
- **MX2M-4TPX-IB / MX2M-4TPX-OB** - Audio+video signal extension over a CATx cable, up to 4K60 resolution. The output board is compatible with all HDMI-TPX-100 and HDMI-TPX-209 series point-to-point SDVoE receivers - see more details in the [AV Signal Extension over SDVoE Interface](#) section.

5.4.1. Audio Signal Extension over Dante Interface

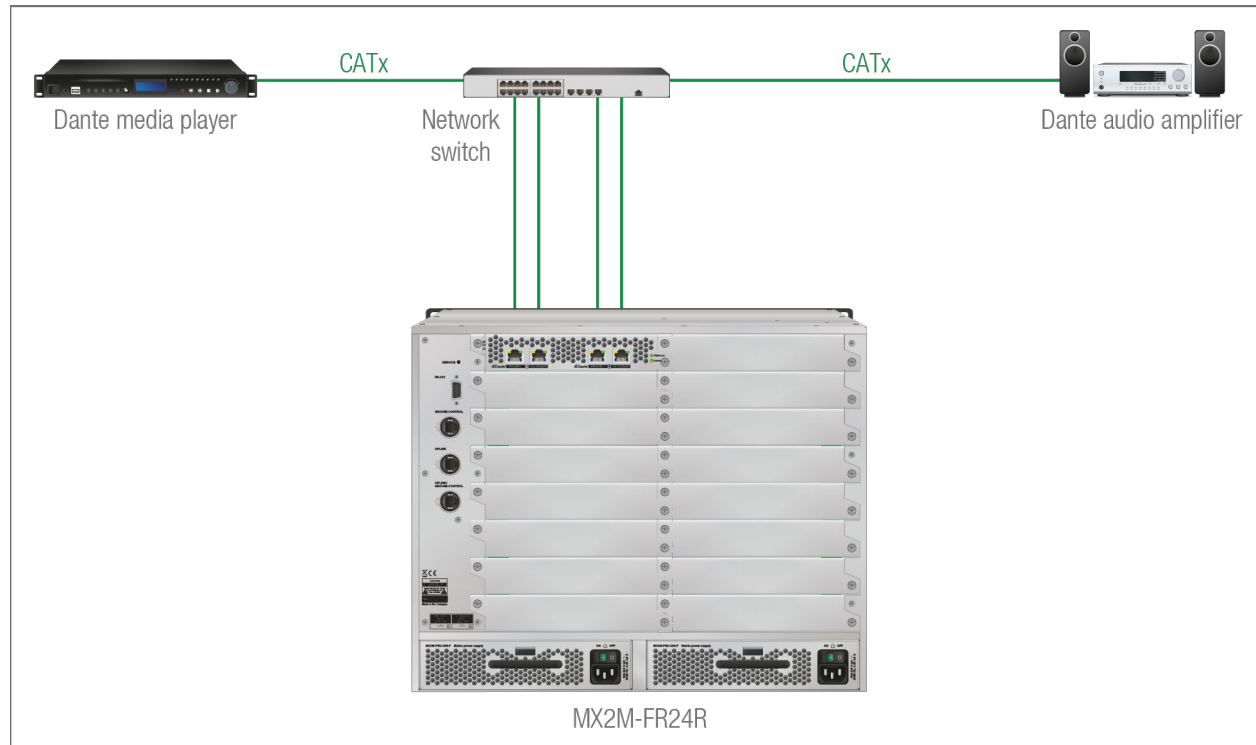

Affected Board:

- [MX2M-AUX-DANTE-32CH](#)

The Concept

Digital AoE (Audio over Ethernet) signals can be received and transmitted over the Dante audio interface. The input signals can be routed to any interface within the matrix, for example it can be embedded into the HDMI output signal or transmitted as analog audio. The Dante output signal can be sourced from any other input signal type, for example it can be de-embedded from the HDMI signal or can be received from a microphone as analog audio input.

The Dante/AES67 signal extension can be maximized using an L2/L3 managed network switch for the connections between the MX2M-AUX-DANTE-32CH board and the audio source and sink devices.

INFO: More information can be found about the network configuration in the [Switch Setup for Dante® Audio Signal Transmission](#) section.

See the details about the maximum cable extensions in the [CATx Cable Distances for Dante](#) section.

5.4.2. AV Signal Extension over Fiber Optical Cable

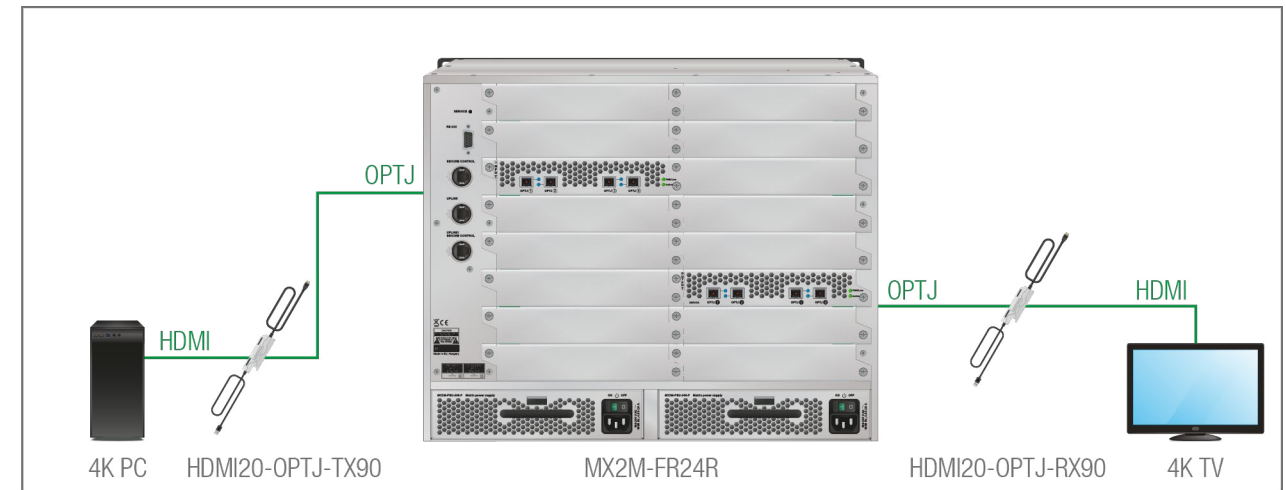

Affected Boards:

- [MX2M-4OPTJ-IB](#)
- [MX2M-4OPTJ-OB](#)

The Concept

The MX2M-4OPTJ-IB and MX2M-4OPTJ-IB-E input boards can receive AV signals of up to 4K60 4:4:4 resolution over a single fiber optical cable. The boards are fully compatible with the Lightware HDMI20-OPTJ-TX90 fiber optical transmitter.

The MX2M-4OPTJ-OB and MX2M-4OPTJ-OB-E output boards can transmit AV signals of up to 4K60 4:4:4 resolution over a single fiber optical cable. The boards are fully compatible with the Lightware HDMI20-OPTJ-RX90 fiber optical receiver.

See the details about the maximum cable extensions in the [Fiber Optical Cable Distances](#) section.

5.4.3. AV Signal Extension over SDVoE Interface

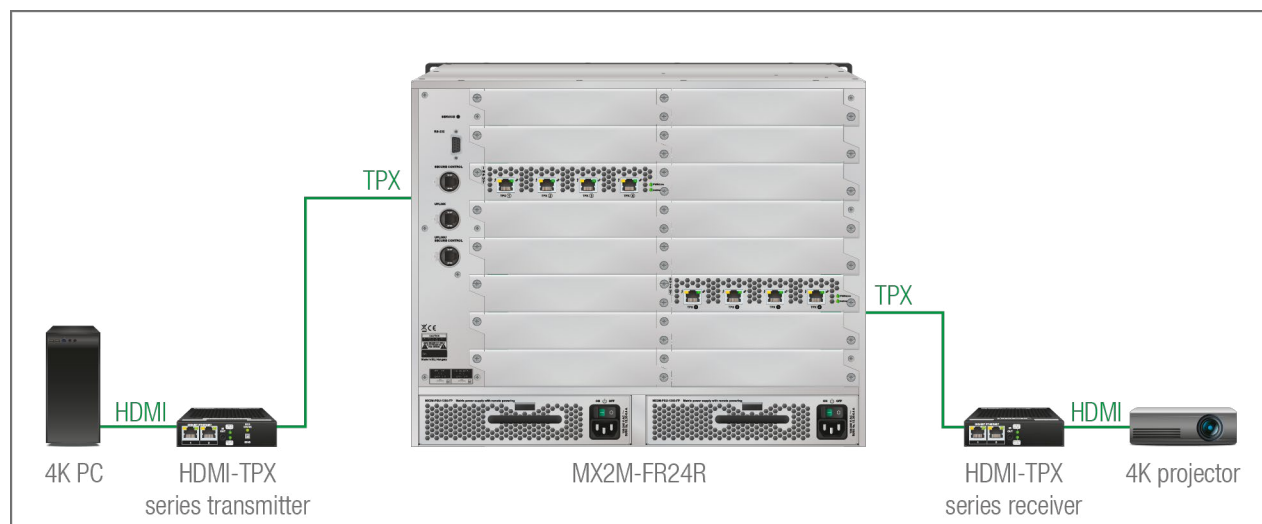

Affected Boards:

- [MX2M-4TPX-IB](#)
- [MX2M-4TPX-OB](#)

The Concept

The MX2M-4TPX-IB input board can receive AV signals of up to 4K60 4:4:4 resolution over a single CATx cable. User Ethernet signal can also be transmitted together with the AV signals. The board is fully compatible with the Lightware HDMI-TPX-TX106 / TX107 and HDMI-TPX-TX209 series SDVoE transmitters.

MX2M-4TPX-OB output board can transmit AV signals of up to 4K60 4:4:4 resolution over a single CATx cable. User Ethernet signal can also be transmitted together with the AV signals. The boards are fully compatible with the Lightware HDMI-TPX-RX106 / RX107 and HDMI-TPX-RX209 series SDVoE receivers.

INFO: Lightware recommends HDMI-TPX-107 and -209 series extenders for the matrix because of the PoE-supplement. HDMI-TPX-106 series extenders are not PoE-capable devices however they are fully compatible with the MX2M-4TPX series I/O boards.

See the details about the maximum cable extensions in the [CATx Cable Distances for TPX](#) section.

Remote Power Capability

The TPX series input and output boards are PoE-compatible, which means they are able to provide 48V power to the connected HDMI-TPX series transmitters or receivers or any third-party SDVoE extender devices. The boards are able to send power over all four TPX ports at the same time.

ATTENTION: The matrix frame must be built with an [MX2M-PSU-1250-FP](#) power drawer to fulfill the remote powering option. For more details, see the [Model Comparison](#) section.

5.5. Ethernet Layer

INFO: All three Ethernet ports of matrix (**Secure Control; Uplink; Uplink/Secure Control**) are equivalent and they can be used for controlling the system.

5.5.1. Control Mode

The matrix can be controlled using the three Ethernet ports with Neutrik RJ45 connectors, which provide 1 GbE data transmission each. The ports accept cables built with Neutrik and RJ45 connectors as well.

The device can be controlled over the Ethernet interface using different methods. See the details about it in the [Software Control Modes](#) section.

5.5.2. Firmware Update Mode

The firmware update of the matrix frame can be applied over the Ethernet interface using the Ethernet ports.

The firmware files of the I/O boards are built in the firmware package of the matrix. The firmware update of the I/O boards is done over the internal Ethernet layer. See the details about the firmware update procedure in the [Firmware Updating of the I/O Boards](#) section.

5.5.3. User Ethernet Mode

The MX2M series matrix switchers use the **User Ethernet mode**, which acts roughly as an unmanaged Ethernet switch from the point of the customer. The User Ethernet mode provides three equal ports for the customer UP1, UP2 and UP3.

Limitations

Since the MX2M Ethernet network transfers internal audio streams and control frames as well, there are some limitations:

- **VLAN ID 100** cannot be used, it is reserved for the internal control frames;
- **VLAN ID 300** cannot be used, it is reserved for the internal audio streams.

ATTENTION: Customer frames with PCP 7 should be avoided in order to preserve the internal audio stream transfer.

5.6. Licensing

Single PSU License

MX2M-FR24R matrix switcher can be purchased with no PSU redundancy. In this case only one PSU drawer is installed with a power supply unit (Power Drawer 1, Primary) and the **Single PSU License** is installed on matrix. In this case, the Power Drawer 2 cannot accept the second PSU drawer. Customers have possibility purchasing a code which makes the Single PSU License inactive. For more details please contact sales@lightware.com.

You can check, add or remove licenses to the system with two methods:

- via **Built-in website / Lightware Device Controller (LDC)** software - see the details in the [Overview](#) section;
- using **LW3 protocol commands** - see the details in the [Adding License](#) and [Removing License](#) sections.

5.7. Further Built-in Features

5.7.1. Device Cloning – Configuration Backup and Restore

The device (configuration) cloning of MX2M matrix switcher is a simple method that eliminates the need to repeatedly configure certain devices to have identical (non-factory) settings. If the devices are installed in the same type of system multiple times, then it is enough to set up only one device to fit the user's needs and then copy those settings to the others, thus saving time and resources.

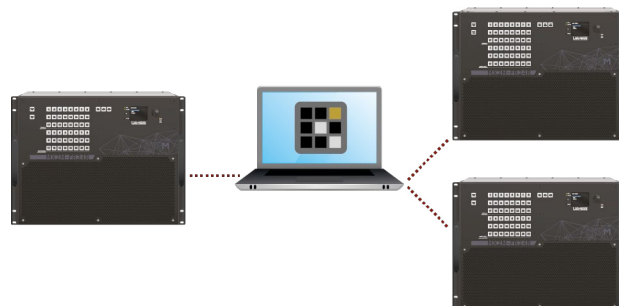

See more information about the settings in the [System](#) section.

5.7.2. Advanced EDID Management

Factory Preset EDIDs

The factory EDIDs (F1-F148) are factory preprogrammed and cannot be modified. These are the most common signal formats. They are specially provided to force graphic cards to output only the exact pixel resolution and refresh rate.

Universal EDID allows multiple resolutions including all common VESA defined resolutions. The use of universal EDID is recommended for fast and easy system setup.

Sources and Destinations

The EDID memory consists of four parts:

- **Factory EDID** list shows the pre-programmed EDIDs (F1-F148).
- **Dynamic EDID** list shows the sink connected to the device's outputs (D1-D24). The unit stores the last display devices' EDID on either output, so there is an EDID shown even if there is no display device attached to the output port at the moment.
- **User memory** locations (U1 – U100) can be used to save custom EDIDs.
- **Emulated EDID** list shows the currently emulated EDID for the inputs (E1-E24). The source column displays the memory location that the current EDID was routed from.

The source reads the EDID from the Emulated EDID memory on the input port. Any EDID from any of the User/Factory/Dynamic EDID lists can be copied to the emulated EDID memory.

There are two types of emulation: **static** and **dynamic**.

- **Static EDID emulation:** an EDID from the Factory or User EDID list is selected. Thus, the Emulated EDID remains the same until the user emulates another EDID.
- **Dynamic EDID emulation:** it can be enabled by selecting D1-D24 EDID memory. The attached monitor's EDID is copied to the input; if a new monitor is attached to the output, the emulated EDID changes automatically.

See more information about the settings in the [EDID Management Menu](#) section in the LDC software.

5.8. Software Control Modes

User has more possibilities to control the device besides the front panel buttons. The following list contains the software control modes:

- **Built-in website / Lightware Device Controller (LDC):** you can connect to the device via our control software with using USB, RS-232 or Ethernet interfaces and control or configure the device as you wish. For the details, see the [Software Control - Lightware Device Controller](#) chapter.
- **LW3 protocol commands:** you can configure the device by using the full-range command set of LW3 protocol. For more details, see the [LW3 Programmers' Reference](#) chapter.

6

Software Control - Built-in Website

The built-in website of the Matrix Management Unit allows to connect to and control the matrix via a web browser. The range of the controlling features are the same as in the case of Software Control - Lightware Device Controller.

- ▶ Establishing the Connection 52
- ▶ The Layout of the Built-in Web 52

System Requirements

Operating System: Microsoft Windows 10, Apple macOS, Linux.

Web Browser: Mozilla Firefox, Google Chrome, Apple Safari.

ATTENTION: The EDID export function works only in Windows and macOS operating systems under Mozilla Firefox or Google Chrome web browsers.

6.1. Establishing the Connection

ATTENTION: Please make sure that the computer is in the same network as the matrix switcher. If the computer has multiple Ethernet connections (for example Wi-Fi and LAN connections are used simultaneously), you will need to know the **IP address** for the one that is used for controlling the system. *#builtinweb #web*

Step 1. Connect the matrix and the computer either via

- Ethernet, with LAN patch cable, or
- Ethernet, with LAN cross cable.

Step 2. Change to the desired IP settings if needed.

Step 3. Type the IP address to the address bar of the web browser and press enter (the factory default network setting is the DHCP (dynamic IP address)).

6.2. The Layout of the Built-in Web

The built-in web page allows the same controlling functions that are available via the **Lightware Device Controller**. Select a menu item on the left side; the default screen is the Crosspoint menu.

ATTENTION: Please enable the pop-up windows in your browser; certain contents are only displayed in a new window.

Built-in website of the MX2M-FR24R matrix switcher

7

Software Control - Lightware Device Controller

The device can be controlled by a computer through the Ethernet interface with the Lightware Device Controller (LDC). The software can be installed on a computer with Windows OS or macOS. The application and the User Manual can be downloaded from www.lightware.com.

▶ Install and Update	54
▶ Running the LDC	54
▶ Establishing Connection	54
▶ Crosspoint Menu	56
▶ Video Port Properties Windows	59
▶ Audio Port Properties Windows	63
▶ Presets	66
▶ EDID Management Menu	67
▶ Settings Menu	70
▶ Terminal Window	72
▶ Health Menu	72

7.1. Install and Update

INFO: After the installation, the Windows and the macOS applications have the same look and functionality.

Minimum System Requirement

RAM: 1 GB

Minimum display resolution: 1280x720

Installation for Windows OS

Run the installer. If the User Account Control drops a pop-up message, click **Yes**.

During the installation you will be prompted to select the type of the installation: **normal** and the **snapshot** install:

Normal install	Snapshot install
Available for Windows and macOS	Available for Windows
The installer can update only this instance	Cannot be updated
Only one updateable instance can exist for all users	More than one different version can be installed for all users

Comparison of installation types

ATTENTION: Using the Normal install as the default choice is highly recommended.

Installation for macOS

Mount the DMG file by double clicking on it, and drag the LDC icon over the Applications icon to copy the program into the Applications folder. If you want to copy the LDC into another location, just drag the icon over the desired folder.

Updating of LDC

Step 1. Run the application.

The **Device Discovery** window appears automatically, and the program checks the available updates on Lightware's website and opens the update window if the LDC found updates.

The current and the update version number can be seen at the top of the window and they are shown in this window even with the snapshot install.

The **Update** window can also be opened by clicking on the **About ? icon** and the **Update** button.

Step 2. Set the desired update setting in the **Options** section.

- If you do not want to check for the updates automatically, uncheck the **circle** that contains the green tick.
- If you want to postpone the update, a reminder can be set with different delays from the **drop down list**.
- If the proxy settings traverse the update process, set the proper values, then click on the **OK** button.

Step 3. Click on the **Download update** button to start the update.

The updates can be checked manually by clicking on the **Check now** button.

7.2. Running the LDC

The common way to start the software is to double-click on the LDC icon. But the LDC can be run by command line parameters as follows.

ATTENTION: Please check the **firewall settings** on the **macOS** device. LDC needs to be added to the **exceptions** of the blocked softwares for the proper operation.

Connecting to a Device with Static IP Address

Format: LightwareDeviceController -i <IP_address>:<port>

Example: LightwareDeviceController -i 192.168.0.20:6107

The LDC is connected to a device with the indicated static IP address directly; the Device Discovery window is not displayed. When the port number is not set, the default port is used: 10001 (LW2 protocol). For LW3, devices use the **6107** port number.

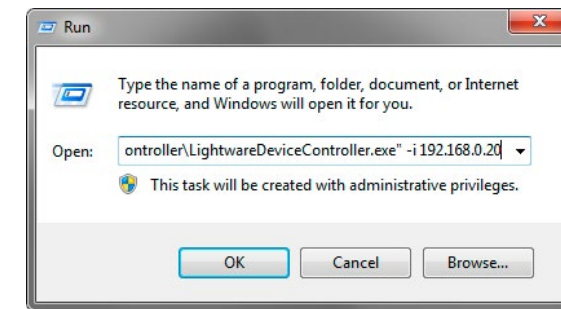

Run window in Windows OS

7.3. Establishing Connection

Step 1. Connect the device to a computer via the following methods:

- Ethernet
- RS-232
- USB

Changing IP Address

To modify IP address settings quickly, it is not necessary to enter the device's settings/network menu, you can set them by clicking on the pencil icon next to the IP address. `#network #ipaddress #dhcp`

You can see the new settings only in this window.

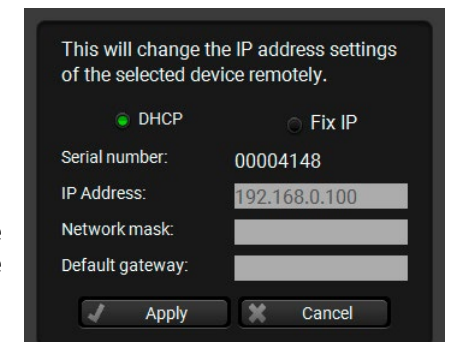

Step 2. Run the controller software; the device discovery window appears automatically.

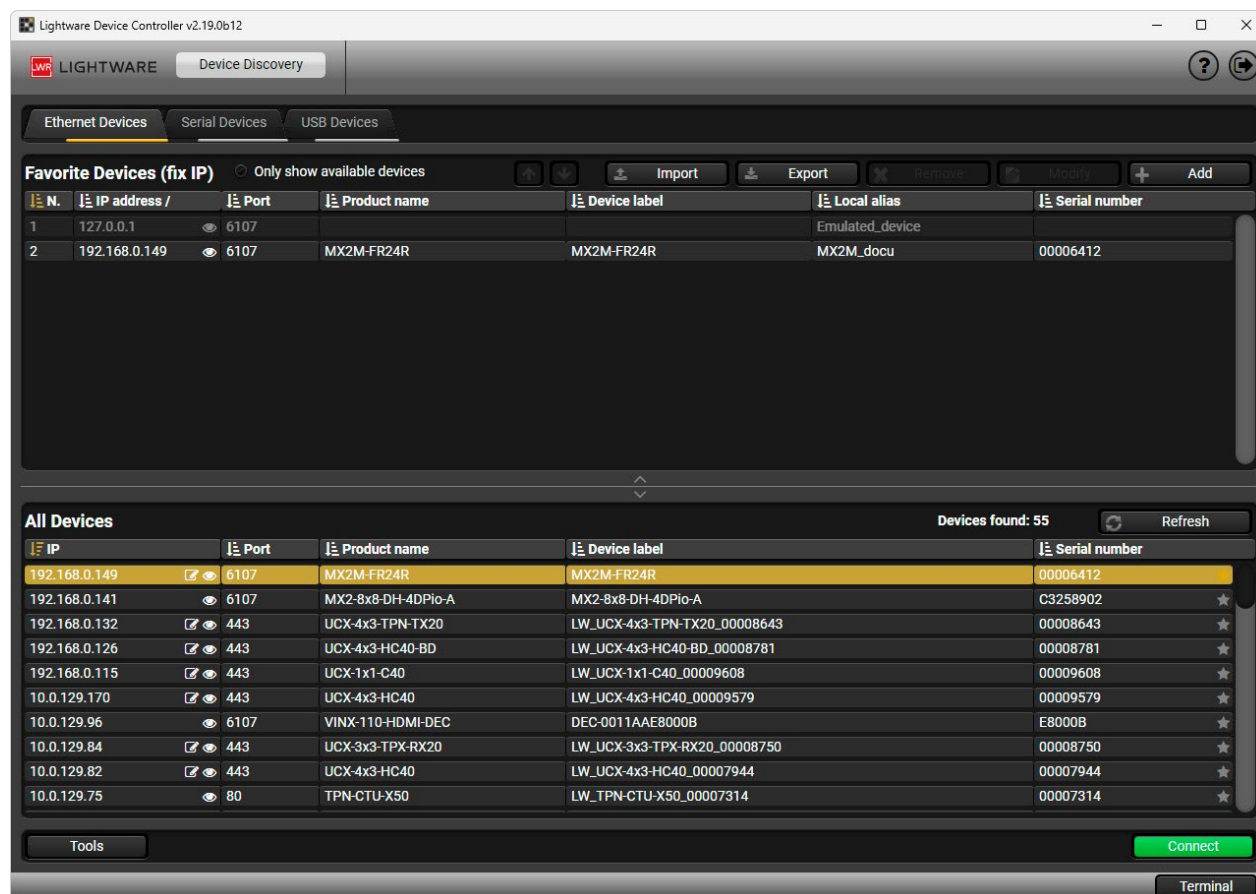

Device discovery window in LDC

Step 3. Select the MX2M-FR24R device from the discovered **Ethernet devices** or **Serial devices**; when the device is connected through RS-232, click on the Query button next to the desired serial port to display the name of the device and the serial number. Double click on the device name or select the device, and click on the green **Connect** button.

Add New Favorite Device

DIFFERENCE: This feature is available in LDC since v2.5.5.

Press the **Add** button; in the appearing window you can enter the **IP address**. The **hostname** of the desired device can be used instead, if it is supported. That allows setting a unique name to identify the device in a network. If the hostname is saved in this window and the IP address is changing, the device will still be available and connectible.

ATTENTION: The hostname connection-feature does not work when the target device is accessed over VPN.

Import/Export the List of Favorite Devices

DIFFERENCE: This feature is available in LDC since v2.5.5.

The list of favorite devices can be exported/imported by the dedicated buttons (saved as *.JSON file). The list can be imported later (in another computer, too), but please note that the current list will be overwritten by the imported list.

Changing the IP Address

To modify the IP address settings quickly, it is not necessary to enter the device's settings/network menu, you can set them by clicking the pencil icon beside the IP address.

You can see the new settings only in this window. The device needs a few seconds to apply the new settings. *#ipaddress*

Identifying the Device

Clicking on the icon results in the blinking of the status LEDs for 10 seconds. The feature helps to find the device itself physically.

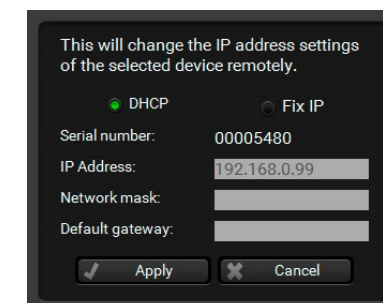
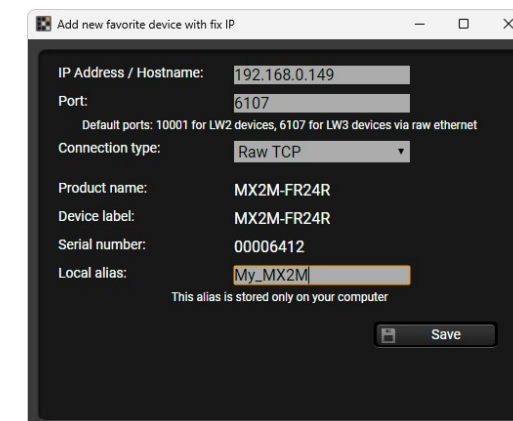

7.4. Crosspoint Menu

7.4.1. Video Layer

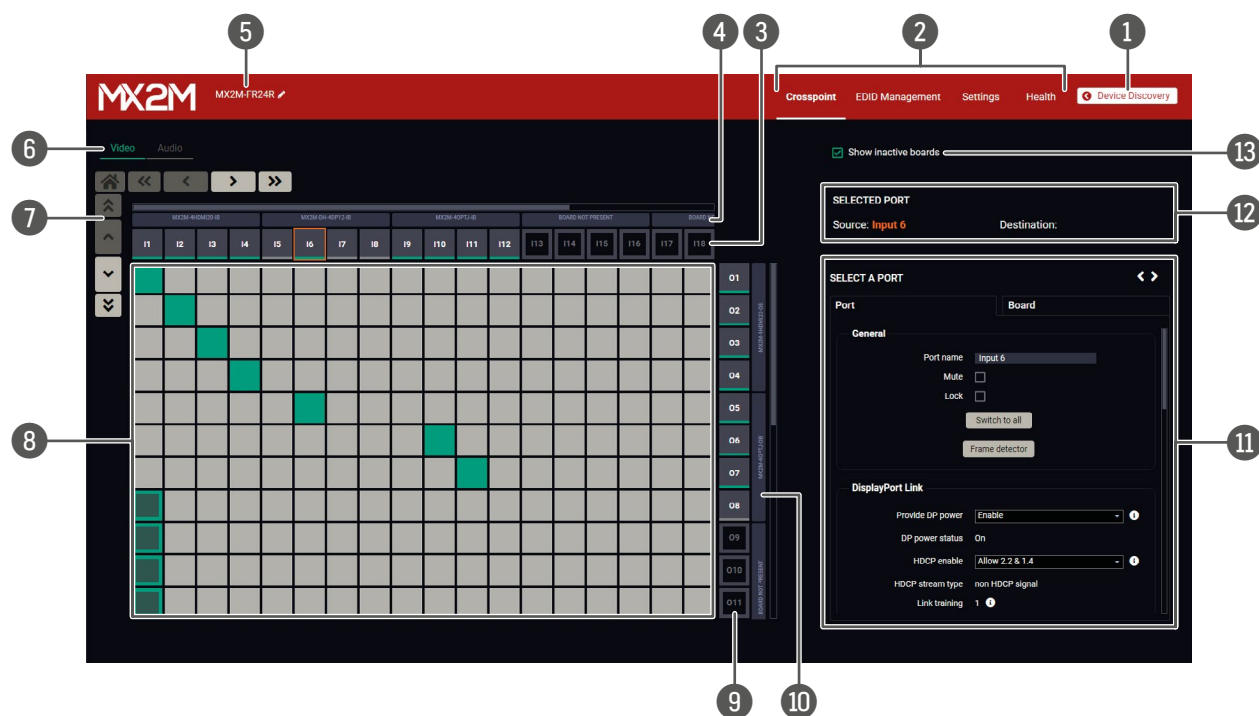

Crosspoint menu - Video layer

Legend of the Crosspoint Menu

- 1 **Device Discovery** Clicking on the button results in returning to the Device Discovery window. The connection with the current device will be terminated.
- 2 **Main menu** The available menu items ([Crosspoint Menu](#), [EDID Management Menu](#), [Settings Menu](#) and [Health Menu](#)) are displayed. The [Terminal Window](#) window is available under the **Settings** menu.
- 3 **Source streams** Each tile represents a video stream coming from one of the input ports of the input boards (IB). Clicking on the tile opens the [Video Port Properties Windows](#) on the right side.
- 4 **Input Boards** The grey bars group the destination ports belonging to a single input board. **Board not present** description means there is no input board seated to the frame or the board is unavailable. Enabling the **Show inactive boards** switcher shows the inactive boards in the crosspoint table.

- 5 **Device label** The device label of the matrix is displayed here. It can be modified by the user to any unique name by clicking on the ✎ icon. The device label can be 39 characters long and ASCII characters are allowed. Longer names will be truncated.
- 6 **Layer tabs** The [Video Layer](#) and the [Audio Layer](#) crosspoint panel can be selected on the tabs.
- 7 **Navigation buttons** Clicking on the navigation buttons shows the available sources/destinations and crosspoints that cannot be displayed within the initial window size. The 🏠 icon resets the grid to the default view.
- 8 **Connections** The crosspoint connections can be selected in this table.
- 9 **Destination ports** Each tile represents an output port of the output boards (OB). Clicking on the tile opens the [Video Port Properties Windows](#) on the right side.
- 10 **Output boards** The grey bars group the destination ports belonging to a single output board. **Board not present** description means there is no output board seated to the frame or the board is unavailable. Enabling of the **Show inactive boards** switcher shows the inactive boards in the crosspoint table.
- 11 **Properties window** The properties, available settings, and status information of the selected source or destination are displayed in this section. Two tabs are available: **Port** and **Board**. See more details about the port settings in the [Video Port Properties Windows](#) section.
- 12 **Selected / Highlighted streams** Showing the currently selected connections. Move the cursor above the desired crosspoint and the names of the source and destination are displayed in the field.
- 13 **Show inactive boards switcher** When it is enabled, the inactive boards are shown in the crosspoint table. When it is disabled, the inactive boards are hidden.

INFO: See the details about the port and crosspoint tiles in the [Legend of the Port Tiles](#) section.

INFO: See more details about video input/output port numbering in the [Video Input/Output Port Numbering](#) section.

#switch #crosspoint #label #devicelabel

7.4.2. Audio Layer

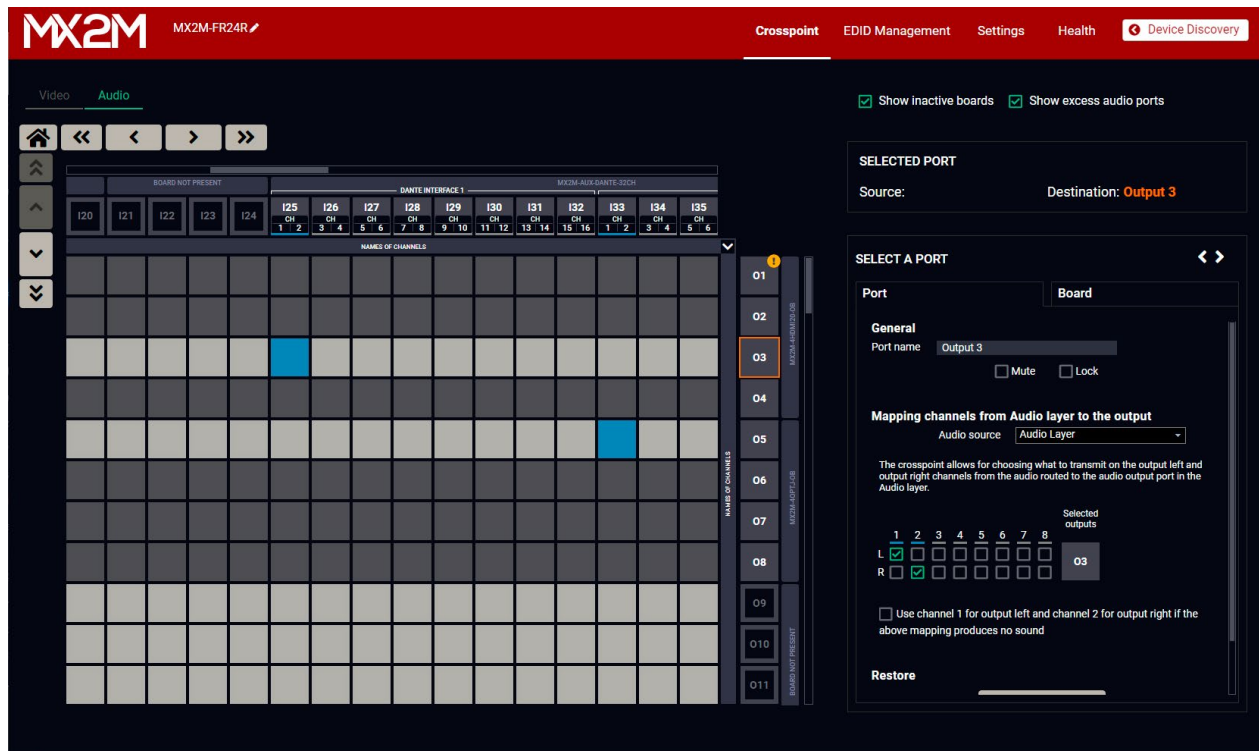

Crosspoint menu - Audio layer

The operation of the Audio layer is basically the same as the [Video Layer](#).

Clicking on the source or the destination port the properties panel opens on the right side - all audio related information and options are available here. See the details about the available settings in the [Audio Port Properties Windows](#) section. *#audio #analogaudio #switch #crosspoint*

INFO: See the details about the port, and crosspoint tiles in the [Legend of the Port Tiles](#) section.

INFO: See more details about audio input/output port numbering in the [Audio Input Port Numbering](#) and the [Audio Output Port Numbering](#) sections.







Dante / AES67 Crosspoint Settings

ATTENTION: Please note that the Dante/AES67 crosspoint operations in the LDC application affects the signal routing within the matrix switcher only. For external Dante/AES67 sources and destinations, please use the [Dante Controller](#) application. See the details in the [Dante® Audio Interface](#) section.

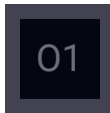





7.4.3. Legend of the Port Tiles

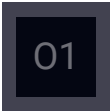

This section helps to easily identify the various types of port and crosspoint tiles on the Crosspoint menu.

Video Layer

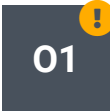
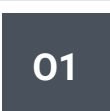
Port tile	Description
Port tiles	
	Port is not available, because there is no I/O board is installed in the related board slot.
	Port is available, but there is no AV signal transmission.
	Port is available and there is AV signal transmission.
Crosspoint tiles	
	No crosspoint connection.
	Crosspoint connection is set, but there is no signal on the selected input port.
	Crosspoint connection is set and the signal transmission is on.

Audio Layer

Port tile	Description
Port tiles	
	Port is not available, because there is no I/O board is installed in the related board slot.
	In case of output ports of the MX2M-AUX-8AUDIO board only: The port on the board is configured as an analog audio input.
	There is no AV signal transmission on the selected input port (signal is undefined).
	Input port is available and there is signal transmission on the selected audio port (for example 2-channel PCM (2.0)).
	There is no AV signal transmission on the selected output port, or the incoming signal is not 2-channel LPCM or uncompressed HBR audio. User needs to define the two audio channel that are to be transmitted - it can be done on the Analog Audio Output Port Properties and the Analog audio output port properties sections.
	Output port is available for signal transmission.
Port tile	Description
Crosspoint tiles	
	No crosspoint connection.
	Unavailable crosspoint.

	Crosspoint connection is set, but there is no signal on the selected input port.
	Crosspoint connection is set and the signal transmission is on.

7.5. Video Port Properties Windows

7.5.1. HDMI / OPTJ Input Port Properties

DIFFERENCE: The following panel is available only when a MX2M-4HDMI20-IB or MX2M-4OPTJ-IB board is installed in the matrix frame.

Clicking on a HDMI or OPTJ input port icon opens the Port properties panel. The most important signal information and settings are available from the panel. `#hdmioptj`

Port Tab

Available Settings and Tools

- **Port naming**
- **Mute/Unmute** `switcher` `#mute`
`#unmute`
- **Lock/Unlock** `switcher` `#lock`
`#unlock`
- **Switch to all button:** clicking on the button switches the selected input stream to all output ports. `#switch`
- **Frame Detector** - The tool displays the frame information of the input stream coming from the input port. `#framedetector`
- **CEC Controller** - The tool is for the remote control of the source or sink device.
- **Maximum supported HDCP version** (HDCP disabled / HDCP 1.4 / HDCP 2.3); `#hdcp`
- **HPD enable (Hot Plug Detect) enable button** (Auto / On / Off); `#hdp` `#hotplugdetect`
- Video stream information;
- Embedded audio information
- Restore **Factory Default Settings** button.

Board Tab

The most important information about the I/O board is available on the tab like the type of the board and the status of board.

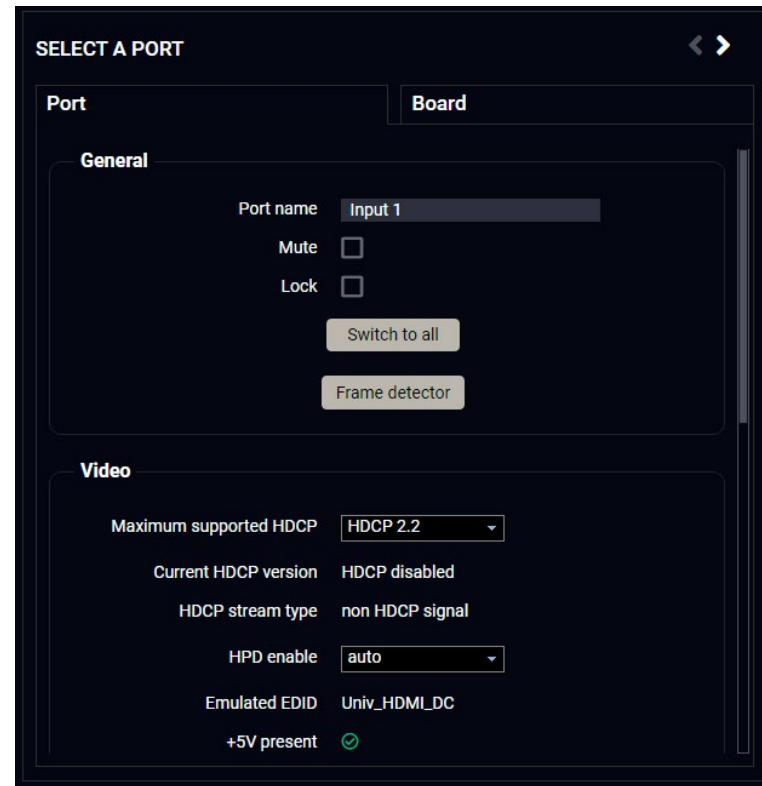

7.5.2. DisplayPort Input Port Properties

DIFFERENCE: The following panel is available only when a MX2M-DH-4DP12-IB board is installed in the matrix frame.

Clicking on a DP input port icon opens the Port properties panel. The most important signal information and settings are available from the panel. `#displayport` `#dp`

Port Tab

Available Settings and Tools

- **Port naming**
- **Mute/Unmute** `switcher` `#mute`
`#unmute`
- **Lock/Unlock** `switcher` `#lock`
`#unlock`
- **Switch to all button:** clicking on the button switches the selected input stream to all output ports. `#switch`
- **Frame Detector** - The tool displays the frame information of the input stream coming from the input port. `#framedetector`
- **Provide DP power** (Enable / Disable): if enabled, the board sends 1.5W power on the chosen port. `#dppower`
- **HDCP enable** (Disable / Allow 1.4 only / Allow 2.3 & 1.4 / High value mode); `#hdcp`
- **Link datarate** (Max RBR 1.62 Gbps / Max HBR 2.7 Gbps / Max HBR2 5.4 Gbps);
- **Link lane count** (Max 1 lanes / Max 2 lanes / Max 4 lanes);
- **Conversion mode** (Passthrough / RGB 4:4:4 to YCbCr 4:2:2 12 bit / RGB 4:4:4 to YCbCr 4:2:0 8 bit); `#colorspace`
- **Restart link training** button; `#linktraining`
- Video stream information;
- Embedded audio information.
- Restore **Factory Default Settings** button.

Board Tab

The most important information about the I/O board is available on the tab like the type of the board and the status of board.

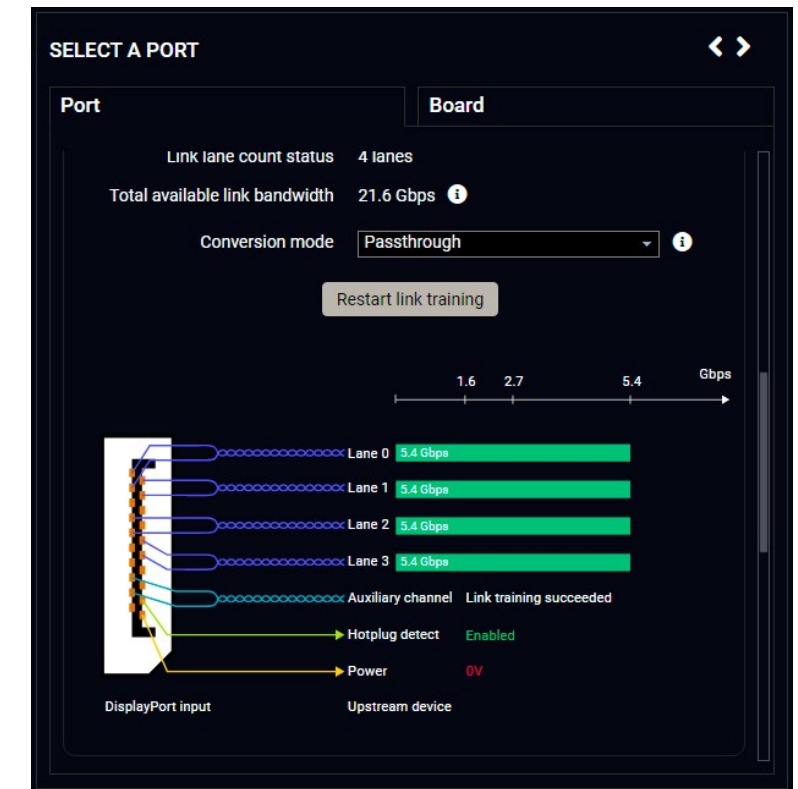

7.5.3. TPX Input Port Properties

DIFFERENCE: The following panel is available only when a **MX2M-4TPX-IB** board is installed in the matrix frame.

Clicking on a TPX input port icon opens the Port properties panel. The most important signal information and settings are available from the panel. [#tpx](#)

Port Tab

Available Settings and Tools

- **Port naming**
- **Mute/Unmute switcher** [#mute](#) [#unmute](#)
- **Lock/Unlock switcher** [#lock](#) [#unlock](#)
- **Switch to all button:** clicking on the button switches the selected input stream to all output ports. [#switch](#)
- **Frame Detector** - The tool displays the frame information of the input stream coming from the input port. [#framedetector](#)
- **CEC Controller** - The tool is for the remote control of the source or sink device.
- **PoE state and PoE enable setting** - enabling of PoE setting allows to send power to the connected TPX extender (false / true). [#poe](#)
- **Maximum supported HDCP version** (HDCP disabled / HDCP 1.4 / HDCP 2.3); [#hdcv](#)
- **HPD enable (Hot Plug Detect) enable button** (Auto / On / Off); [#hdp](#) [#hotplugdetect](#)
- Video stream information;
- Embedded audio information.
- Restore **Factory Default Settings** button.

Board Tab

The most important information about the I/O board is available on the tab like the type of the board and the status of board.

7.5.4. HDMI / OPTJ Output Port Properties

DIFFERENCE: The following panel is available only when a **MX2M-4HDMI20-OB** or **MX2M-4OPTJ-OB** board is installed in the matrix frame.

Clicking on a HDMI or OPTJ output port icon opens the Port properties panel. [#hdmv](#) [#optj](#)

Port Tab

Available Settings and Tools

- **Port naming**
- **Mute/Unmute switcher** [#mute](#) [#unmute](#)
- **Lock/Unlock switcher** [#lock](#) [#unlock](#)
- **Frame Detector** - The tool displays the frame information of the input stream coming from the input port. [#framedetector](#)
- **CEC Controller** - The tool is for the remote control of the source or sink device.
- **HDCP:** [#hdcv](#)
 - Depends on input: the level and version of HDCP-encryption depends on the source device;
 - Maximum possible: the output ports set the maximum HDCP-encryption level that the connected sink device can accept.
- **5V enable switcher** (on / off / auto); [#power5v](#)
- **Conversion mode** (Passthrough / YCbCr 4:2:2); [#colorspace](#)
- Video stream information;
- **Audio source:** [#embedder](#) [#audio](#)
 - HDMI: the original embedded audio is transmitted with the stream. When the crosspoint connection is changed on the Video layer, the embedded audio will be changed as well.
 - Audio layer: the audio signal is selected from the Audio layer. *
 - OFF: audio signal is disabled.
- **Mapping channels for Audio layer to the output:** the embedded audio signal can be 2-channel LPCM or compressed (non-HBR) audio signal only. There are two possibilities in case of audio signal embedding:
 - If the selected signal includes more than two audio channels, the user can select the two channels that are to be transmitted.
 - If the selected signal is compressed (non-HBR) audio, it can be embedded into the video stream without any further action. [#mapping](#) [#channelmapping](#)
- Restore **Factory Default Settings** button.

Board Tab

The most important information about the I/O board is available on the tab like the type of the board and the status of board.

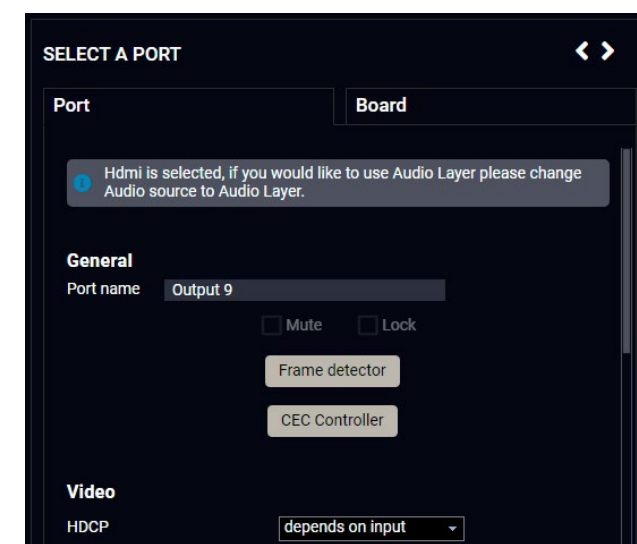

7.5.5. TPX Output Port Properties

DIFFERENCE: The following panel is available only when a MX2M-4TPX-OB board is installed in the matrix frame.

Clicking on a TPX output port icon opens the Port properties panel. [#tpx](#)

Available Settings and Tools

- **Port naming**
- **Mute/Unmute switcher** [#mute](#) [#unmute](#)
- **Lock/Unlock switcher** [#lock](#) [#unlock](#)
- **Frame Detector** - The tool displays the frame information of the input stream coming from the input port. [#framedetector](#)
- **PoE state and PoE enable setting** - enabling of PoE setting allows to send power to the connected TPX extender (false / true). [#poe](#)
- **HDCP:** [#hdcp](#)
 - Depends on input: the level and version of HDCP-encryption depends on the source device;
 - Maximum possible: the output ports set the maximum HDCP-encryption level that the connected sink device can accept.
- **5V enable switcher** (on / off / auto); [#power5v](#)
- **Conversion mode** (Passthrough / YCbCr 4:2:2); [#colorspace](#)
- Video stream information;
- **Audio source:** [#embedder](#) [#audio](#)
 - Original embedded audio: the original embedded audio is transmitted with the stream. When the crosspoint connection is changed on the Video layer, the embedded audio will be changed as well.
 - Audio layer: the audio signal is selected from the Audio layer.
 - OFF: audio signal is disabled.

Board Tab

The most important information about the I/O board is available on the tab like the type of the board and the status of board.

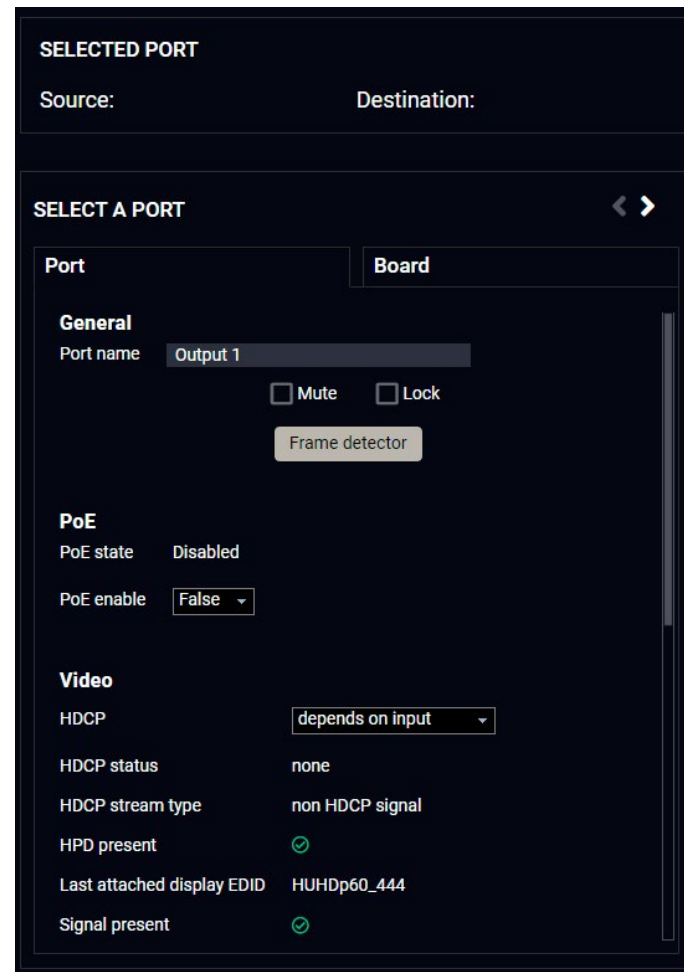

7.5.6. Frame Detector

The ports can show detailed information about the signal like blanking intervals and active video resolution. This feature can be used for troubleshooting if compatibility problems occur during system installation. To access this function, open the port properties window and click on the **Frame detector** button.



Frame detector window

Lightware's Frame Detector function works like a signal analyzer and allows to determine the exact video format that is present on the port, thus it helps to identify various problems. E.g. actual timing parameters may differ from the expected and this may cause some displays to drop the picture.

Frame Detector measures detailed timings of the video signals just like a built-in oscilloscope, but it is much easier to use. Actual display area shows the active video size (dark grey). Black area of the full frame is the blanking interval, which can contain the info frames and embedded audio data for HDMI signals. Shown values are measured on the actual signal and not retrieved only from the HDMI info frames. [#framedetector](#)

7.5.7. CEC Controller

DIFFERENCE: The following panel is available only when a **MX2M-4HDMI20-IB**, **MX2M-4OPTJ-IB**, **MX2M-4TPX-IB**, **MX2M-4HDMI20-OB** or **MX2M-4OPTJ-OB** board is installed in the matrix frame.

The MX2M-4HDMI20 and MX2M-4OPTJ series I/O boards are able to send and receive Consumer Electronics Control (CEC) commands. This feature is for remote control of the source or sink device. CEC is a bi-directional communication via HDMI cable.

ATTENTION: It can occur that the third-party device can receive, but not execute the command because it is not supported by the product. Check the accepted commands in the documentation of the device.

INFO: The first 2x2 bytes of the CEC commands contain identification data of the source and destination address. When the port is input, it is always 04 (from TV to Playback device 1.); when the port is output, it is always 40 (from Playback device 1. to TV).

The CEC panel is available on the port properties window of the **HDMI input**, **HDMI output**, **OPTJ input** and **OPTJ output** ports.

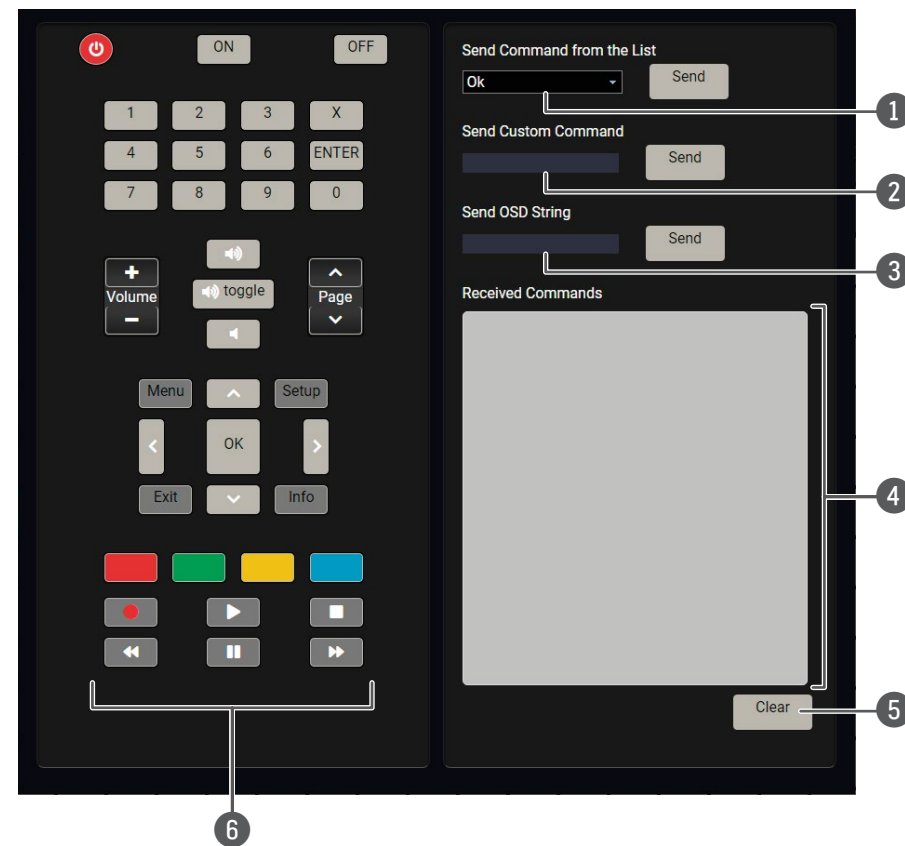

CEC control panel on the HDMI out port properties window

- 1 **Drop-down command list** This list contains the basic CEC commands, most of them are displayed on the graphical interface, too (on the left side). Click on the **Send** button to send the command.
- 2 **Custom command textbox** The text field is for sending Hexadecimal commands to the source. The maximum length of the message could be 30 characters (15 bytes). Click on the **Send** button to send the command.
- 3 **OSD string textbox** A max. 14-character-long text can be shown on the sink device. The send OSD (On-screen display) command textbox is the input field of the string. Alphanumeric characters, glyphs and space are accepted. Click on the **Send** button to execute the command.
- 4 **Received Command box** Displays all the sent (in red) CEC commands and the received answers (in blue) with a timestamp.

Legend of the received message:

< [10:33:17] ACK

Answer for the acknowledged command.

< [10:35:01] NACK

Answer for the not acknowledged command.

< [10:33:17] IN PROGRESS

The command is in progress at the moment.

< [10:33:17] FAILED

Answer for other failure.

< [10:35:40] feature_abort_<*>

This is the most common answer from the third-party devices when the command is delivered, but the execution is refused. The cause of the refusal stands after 'feature_abort' expression.

- 5 **Clear button** Click on the **Clear** button to erase the content of the terminal window.
- 6 **CEC command button panel** This panel provides quick and easy management of CEC commands. These buttons are pre-programmed with basic functions and send commands towards the sink. The communication is displayed in the Received Command box. For the list of the commands, see the [Sending CEC Commands](#) section. Both the layout and functionality are similar to the design of a remote control.

ATTENTION: Make sure that the controlled unit is CEC-capable and this function is enabled.

#cec

7.6. Audio Port Properties Windows

7.6.1. Digital Audio Input Port Properties

DIFFERENCE: The following panel is available only when a MX2M-4HDMI20-IB, MX2M-4OPTJ-IB, MX2M-4TPX-IB or MX2M-DH-4DP12-IB board is installed in the matrix frame.

Clicking on a digital audio input port icon opens the Port properties panel. The most important signal information and settings are available from the panel. `#audio #hdmi #optj #displayport #dp`

Port Tab

Available Settings and Tools

- **Port naming**
- **Mute/Unmute** **switcher** `#mute #unmute`
- **Lock/Unlock** **switcher** `#lock #unlock`
- **Switch to all button:** clicking on the button switches the selected input stream to all output ports. `#switch`
- Audio signal related information;
- Restore **Factory Default Settings** button.

Board Tab

The most important information about the I/O board is available on the tab like the type of the board and the status of board.

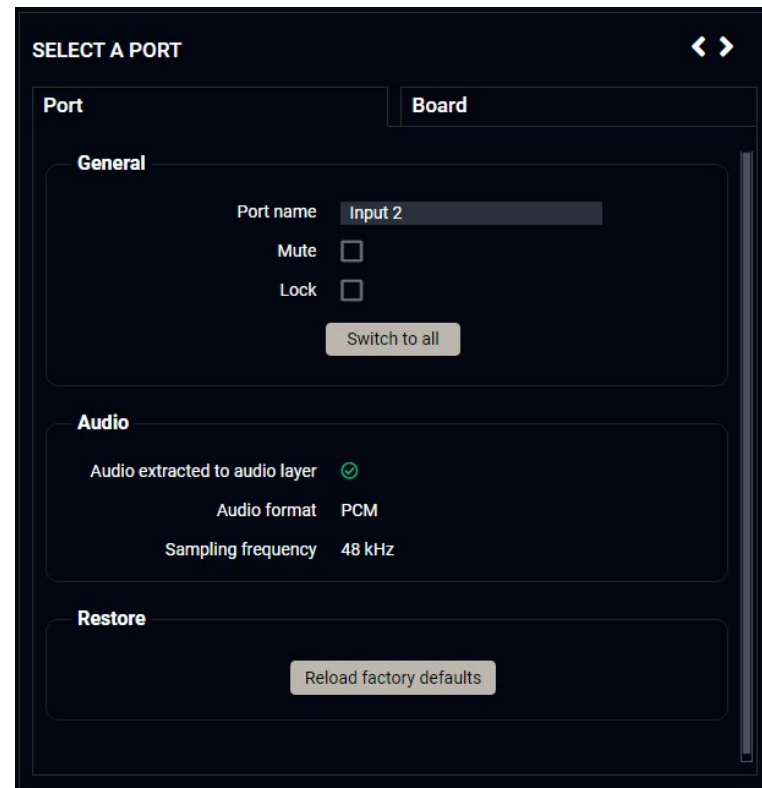

7.6.2. Digital Audio Output Port Properties

DIFFERENCE: The following panel is available only when a MX2M-4HDMI20-OB, MX2M-4OPTJ-OB or MX2M-4TPX-OB board is installed in the matrix frame.

Clicking on a HDMI or OPTJ output port icon opens the Port properties panel. The most important signal information and settings are available from the panel. `#audio #hdmi #optj`

Port Tab

Available Settings and Tools

- **Port naming**
- **Mute/Unmute** **switcher** `#mute #unmute`
- **Lock/Unlock** **switcher** `#lock #unlock`
- **Audio source:** `#embedder`
 - HDMI: the original embedded audio is transmitted with the stream. When the crosspoint connection is changed on the Video layer, the embedded audio will be changed as well.
 - Audio layer: the audio signal is selected from the Audio layer. *
 - OFF: audio signal is disabled.
- **Mapping channels for Audio layer to the output:** the embedded audio signal can be 2-channel LPCM or compressed (non-HBR) audio signal only. There are two possibilities in case of audio signal embedding:
 - If the selected signal is of type LPCM, the user can select the two channels that are to be transmitted.
 - If the selected signal is compressed (non-HBR) audio, it can be embedded into the video stream without any further action. `#mapping #channelmapping`
- Restore **Factory Default Settings** button.

Board Tab

The most important information about the I/O board is available on the tab like the type of the board and the status of board.

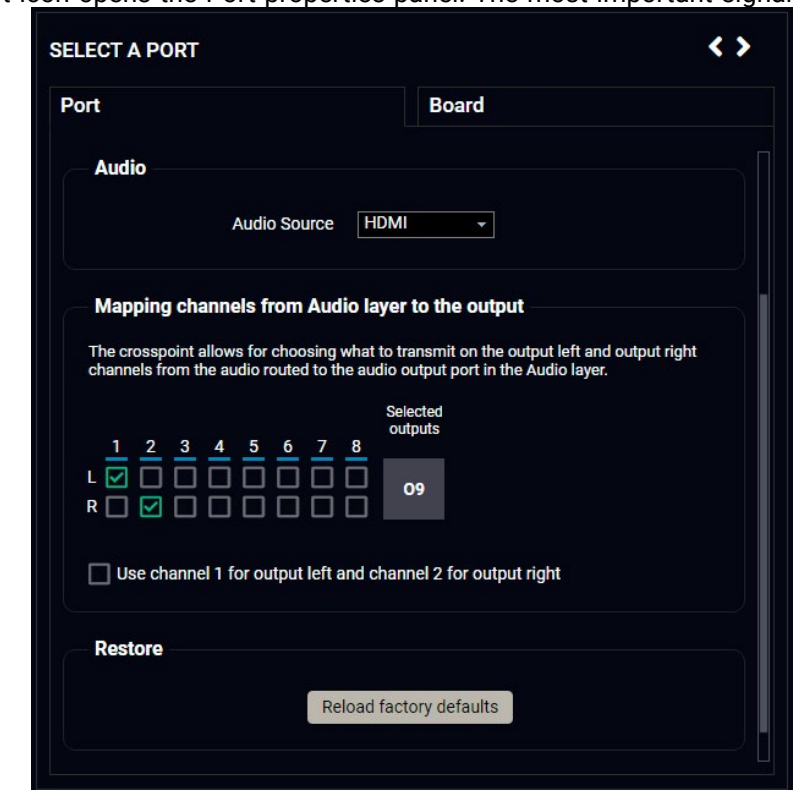

7.6.3. Analog Audio Input Port Properties

DIFFERENCE: The following panel is available only when a **MX2M-AUX-8AUDIO** board is installed in the matrix frame.

Clicking on an analog audio input port icon opens the Port properties panel. The most important signal information and settings are available from the panel. [#audio](#) [#analogaudio](#)

Port Tab

Available Settings and Tools

- Port naming
- Mute/Unmute **switcher** [#mute](#) [#unmute](#)
- Lock/Unlock **switcher** [#lock](#) [#unlock](#)
- Switch to all button:** clicking on the button switches the selected input stream to all output ports. [#switch](#)
- Input gain:** sets the gain between -12 dB and 21 dB. Clicking on the **−** icon results in -1 dB, the **+** icon results in +1 dB in the gain setting. The default value is 0 dB. [#gain](#)
- Input volume:** sets the input volume (attenuation) between 0% (-95.625 dB) and 100% (0 dB). Clicking on the **−** icon results in -1%, the **+** icon results in +1% in the volume setting. The default value is 100%. [#volume](#)
- Input balance:** sets the balance between -100 (total left) and 100 (total right). Clicking on the **−** icon results in -1, the **+** icon results in +1 in the balance setting. The default value is 0 (center). [#balance](#)
- Restore [Factory Default Settings](#) button.

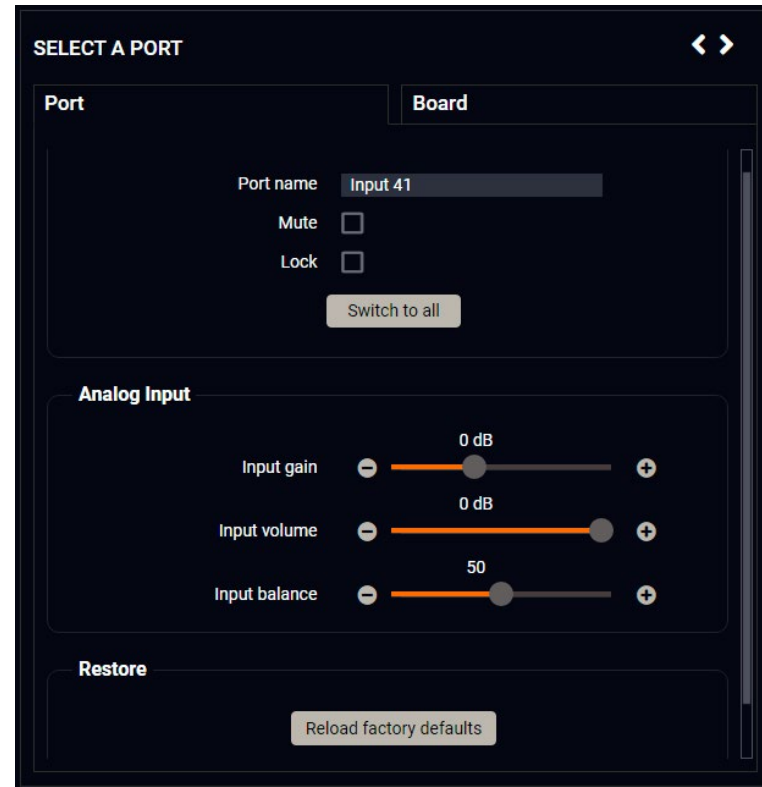

Board Tab

The most important information about the I/O board is available on the tab like the type of the board and the status of board.

7.6.4. Analog Audio Output Port Properties

DIFFERENCE: The following panel is available only when a **MX2M-AUX-8AUDIO** board is installed in the matrix frame.

Clicking on an analog audio output port icon opens the Port properties panel. The most important signal information and settings are available from the panel. [#audio](#) [#analogaudio](#)

Port Tab

Available Settings and Tools

- Port naming
- Mute/Unmute **switcher** [#mute](#) [#unmute](#)
- Lock/Unlock **switcher** [#lock](#) [#unlock](#)
- Output volume:** sets the volume (attenuation) between 0% (-95.625 dB) and 100% (0 dB). Clicking on the **−** icon results in -1%, the **+** icon results in +1% in the volume setting. The default value is 100%. [#volume](#)
- Output balance:** sets the balance between -100 (total left) and 100 (total right). Clicking on the **−** icon results in -1, the **+** icon results in +1 in the balance setting. The default value is 0 (center). [#balance](#)
- Mapping channels for Audio layer to the output:** analog audio output port can convert only LPCM signals, therefore the only option available is the following: if the selected signal is of type LPCM, the user can select the two channels to be transmitted. [#mapping](#) [#channelmapping](#)
- Restore [Factory Default Settings](#) button.

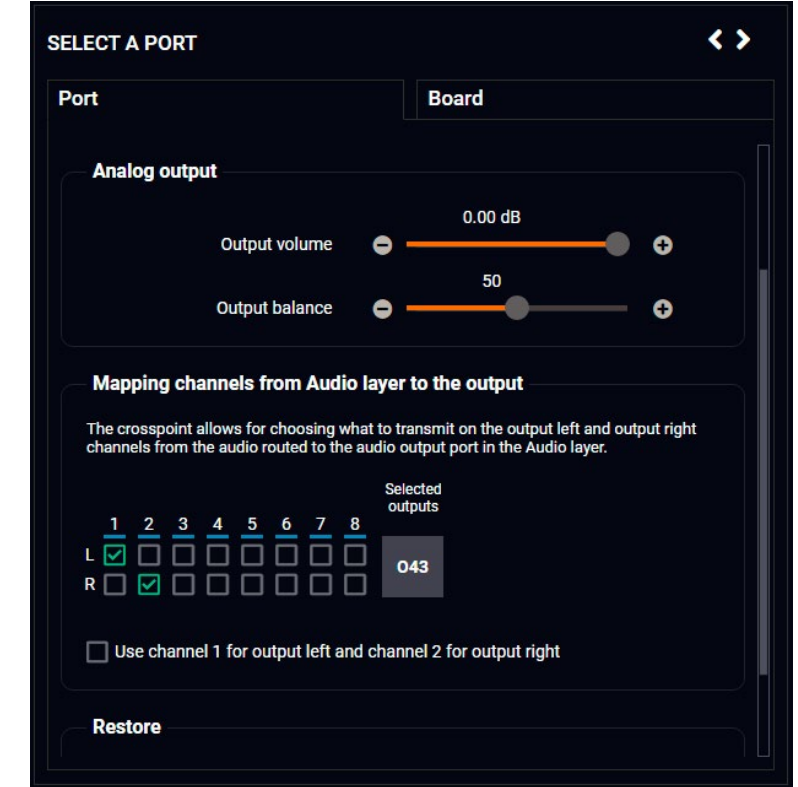

Board Tab

The most important information about the I/O board is available on the tab like the type of the board and the status of board.

7.6.5. Dante® Audio Input Port Properties

DIFFERENCE: The following panel is available only when a MX2M-AUX-DANTE-32CH board is installed in the matrix frame.

Clicking on a Dante audio input port icon opens the Port properties panel. The most important signal information and settings are available from the panel. [#audio](#) [#dante](#) [#aes67](#)

Port Tab

Available Settings and Tools

- Port naming
- Adding Channel label for receive channel 1 and 2
- Mute/Unmute **switcher** [#mute](#) [#unmute](#)
- Lock/Unlock **switcher** [#lock](#) [#unlock](#)
- Switch to all button:** clicking on the button switches the selected input stream to all output ports. [#switch](#)
- Restore [Factory Default Settings](#) button.

Board Tab

- Device naming
- IP address mode for Primary and Secondary interfaces: Unknown/Query / LinkLocal / DHCP or LinkLocal / DHCP / Static
- TX channel naming: from TX channel 1 to 16.
- RX channel naming: from RX channel 1 to 16.
- Restore [Factory Default Settings](#) button.

7.6.6. Dante® Audio Output Port Properties

DIFFERENCE: The following panel is available only when a MX2M-AUX-DANTE-32CH board is installed in the matrix frame.

Clicking on a Dante audio output port icon opens the Port properties panel. The most important signal information and settings are available from the panel. [#audio](#) [#dante](#) [#aes67](#)

Port Tab

Available Settings and Tools

- Port naming
- Mute/Unmute **switcher** [#mute](#) [#unmute](#)
- Lock/Unlock **switcher** [#lock](#) [#unlock](#)
- Mapping channels for Audio layer to the output:** the embedded audio signal can be 2-channel LPCM only. If the selected signal includes more than two audio channels, the user can select the two channels to be transmitted. [#mapping](#) [#channelmapping](#)
- "Use channel 1 for output left and channel 2 for output right if the above mapping produces no sound" **switcher**
- Restore [Factory Default Settings](#) button.

Board Tab

- Device naming
- IP address mode for Primary and Secondary interfaces: Unknown/Query / LinkLocal / DHCP or LinkLocal / DHCP / Static
- TX channel naming: from TX channel 1 to 16.
- RX channel naming: from RX channel 1 to 16.
- Restore [Factory Default Settings](#) button.

7.7. Presets

Select the Crosspoint / Presets menu to open the preset operations of the matrix. #preset

The router can store presets and the following are stored in each slot: input/output crosspoint state, muted/unmuted states. Preset loading has an effect on all ports, except the locked ones.

ATTENTION: When factory default settings are restored, presets are deleted.

ATTENTION: The Preset loading has an effect on all ports, except the locked ones.

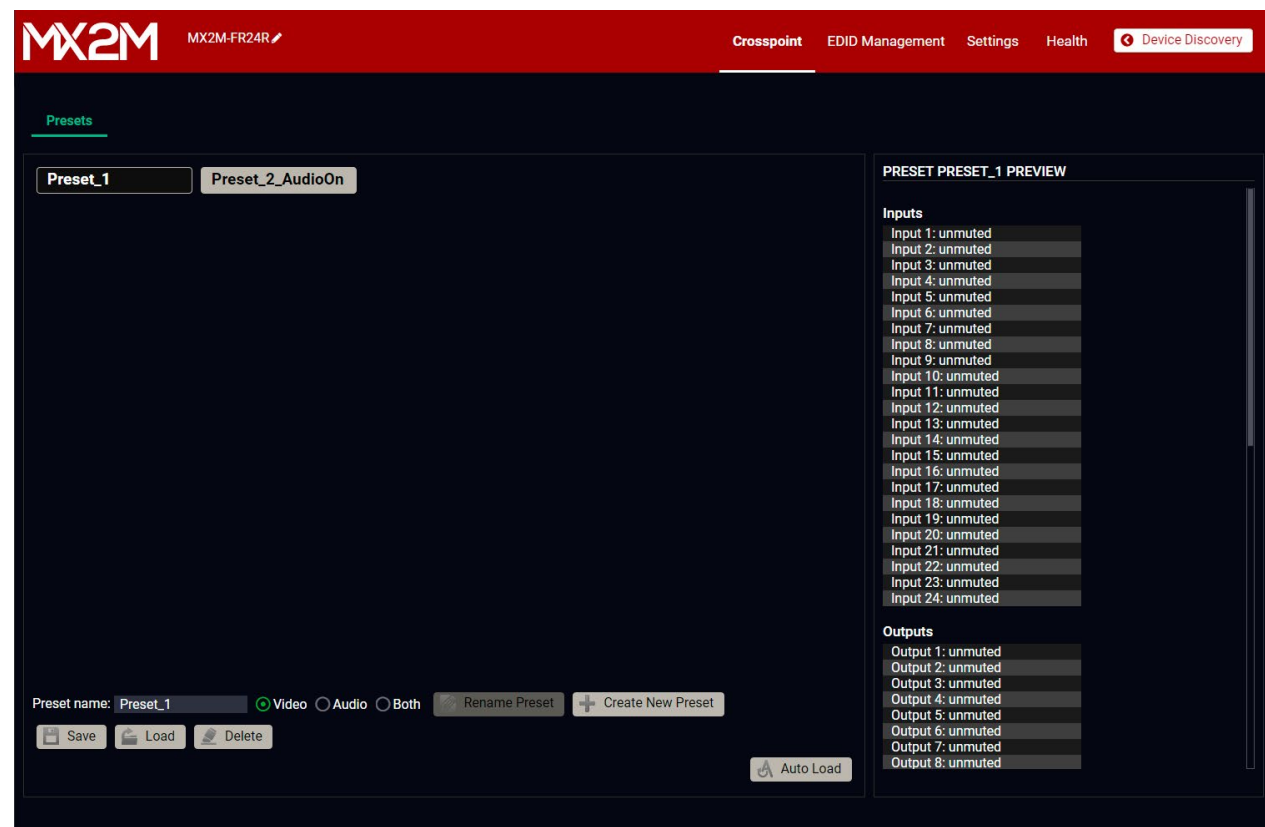

Preset menu

Loading a Preset

Step 1. Select the **Presets** tab from the **Crosspoint** menu.

Step 2. Select the desired preset; check the **Preview** panel and press the **Load** button. Press **Yes** in the confirmation window.

Auto load mode

When the **Auto load** button is highlighted in green, the mode is active. In this case, confirmation is **not** required: the selected preset is loaded immediately when the button is pressed.



Saving a Preset to an Empty Slot

Step 1. Arrange the desired crosspoint connections in **Tile view** or **Grid view**.

Step 2. Select the **Presets** tab from the **Crosspoint** menu and type the desired **Preset name** in the indicated text field up to 16 characters. The following are allowed when naming: letters (A-Z and a-z), hyphen (-), underscore (_), and numbers (0-9).

Step 3. Press the **Create New Preset** button to store the configuration.

Overwriting an Existing Preset

Step 1. Arrange the desired crosspoint connections.

Step 2. Select an existing preset, press the **Save** button and **Yes** to confirm.

Renaming a Preset

Step 1. Select the desired preset you want to rename.

Step 2. Type the desired name and press the **Rename Preset** button.

Deleting a Preset

Step 1. Select the desired preset you want to delete.

Step 2. Press the **Delete** button and **Yes** to confirm.

7.8. EDID Management Menu

Advanced EDID Management can be accessed by selecting the EDID Management menu. There are two panels: the left one contains Source EDIDs, the right one contains Destination places where the EDIDs can be emulated or copied. #edid

EDID Management menu

Control Buttons

	Exporting an EDID (save to a file)		Transfer button: executing EDID emulation or copying
	Importing an EDID (load from a file)		Deleting EDID (from User memory)
	Display EDID Summary window		Selecting all memory places in the right panel
	Opening Advanced EDID Editor with the selected EDID		Selecting none of the memory places in the right panel
	Opening Easy EDID Creator		

7.8.1. EDID Operations

Changing Emulated EDID

- Step 1.** Choose the desired **EDID list** on the source panel and select an **EDID**.
- Step 2.** Press the **Emulated** button on the top of the Destination panel.
- Step 3.** Select the desired **port** on the right panel (one or more ports can be selected); the EDID(s) will be highlighted with a yellow cursor.
- Step 4.** Press the **Transfer** button to change the emulated EDID.

Learning an EDID

The process is the same as changing the emulated EDID; the only difference is the Destination panel: press the **User** button. Thus, one or more EDIDs can be copied into the user memory either from the factory memory or from a connected sink (Dynamic).

Exporting an EDID

Source EDID can be downloaded as a file (*.bin, *.dat or *.edid) to the computer.

- Step 1.** Select the desired **EDID** from the Source panel (line will be highlighted in yellow).
- Step 2.** Press the **Export** button to open the dialog box and save the file to the computer.

Importing an EDID

Previously saved EDID (*.bin, *.dat or *.edid file) can be uploaded to the user memory:

- Step 1.** Press the **User** button on the top of the Source panel and select a **memory** slot.
- Step 2.** Press the **Import** button below the Source panel.
- Step 3.** Browse the file in the opening window, then press the **Open** button. The browsed EDID is imported into the selected User memory.

ATTENTION: The imported EDID overwrites the selected memory place even if it is not empty.

Deleting EDID(s)

The EDID(s) from User memory can be deleted as follows:

- Step 1.** Press the **User** button on the top of the Destination panel.
- Step 2.** Select the desired **memory** slot(s); one or more can be selected (“Select All” and “Select None” buttons can be used). The EDID(s) will be highlighted in yellow.
- Step 3.** Press the **Delete selected** button to delete the EDID(s).

7.8.2. Editing an EDID

Select an EDID from the Source panel and press the **Edit** button to display the Advanced EDID Editor window. The editor can read and write all descriptors that are defined in the standards, including the additional CEA extensions. Any EDID from the device's memory or a saved EDID file can be loaded into the editor. The software resolves the raw EDID and displays it as readable information to the user. All descriptors can be edited, saved in an EDID file, or uploaded to the User memory.

EDIT

	0	1	2	3	4	5	6	7	8	9
0	00	FF	FF	FF	FF	FF	FF	00	4C	2D
10	8E	09	00	00	00	00	09	16	01	03
20	80	34	1D	78	0A	7D	D1	A4	56	50
30	A1	28	0F	50	54	BD	EF	80	71	4F
40	81	C0	81	00	81	80	95	00	A9	C0
50	B3	00	01	01	02	3A	80	18	71	38
60	2D	40	58	2C	45	00	09	25	21	00
70	00	1E	66	21	56	AA	51	00	1E	30
80	46	8F	33	00	09	25	21	00	00	1E
90	00	00	00	FD	00	18	4B	1A	51	17
100	00	0A	20	20	20	20	20	20	00	00
110	00	FC	00	54	32	34	42	33	30	31
120	0A	20	20	20	20	01	6C			

EDID Editor window

7.8.3. Creating an EDID - Easy EDID Creator

Since the Advanced EDID Editor mentioned above needs more detailed knowledge about EDID, Lightware introduced a wizard-like interface for fast and easy EDID creation. With Easy EDID Creator, it is possible to create custom EDIDs in four simple steps. By clicking on the **Create** button below the Source panel, **Easy EDID Creator** is opened in a new window.

CREATE

Select Resolution & Interface

Welcome to the Easy EDID Creator!

With this software you are able to create a unique EDID according to your demands. Details can be added or changed in the Advanced EDID Editor later if needed.

Please select the format type and the preferred resolution. If you don't find the proper mode in the list, use the Custom format type setting, enter the resolution and the program will estimate the best blanking times.

Important notes:

- If you want to send audio then you must select HDMI or DisplayPort. DVI and VGA do not support audio transmission.
- Most DVI displays are not able to process HDMI signals. If you have a DVI display, please check its specifications.
- The supported color depth will be 24bits/pixel by default.

Format type:

Resolution:

Interface type: VGA DVI HDMI DisplayPort

Back Next

EDID Creator window

7.8.4. EDID Summary Window

Select an EDID from the Source panel and press the **Info** button to display the EDID summary.

INFO

The screenshot shows the EDID summary window with a sidebar on the left containing various categories like General, Power Management, Gamma / Colors, etc. The main area is titled 'General' and displays the following information:

EDID version:	1
EDID revision:	3
Manufacturer ID:	SAM (Samsung Electric Company)
Product ID:	8E09
Monitor serial number:	Not present
Year of manufacture:	2012
Week of manufacture:	9
Signal interface:	Digital
Separate Sync H&V:	-
Composite sync on H:	-
Sync on green:	-
Serration on VS:	-
Color depth:	Undefined
Interface standard:	Not defined
Color spaces:	RGB 4:4:4 & YCrCb 4:4:4
Aspect ratio:	0.56
Display size:	52 cm X 29 cm

EDID summary window

7.8.5. DisplayID Extension

The DisplayID is defined by a VESA standard created beside the EDID structure. The Advanced EDID editor gets a DisplayID section, where additional metadata is stored for the video sources about the display capabilities.

INFO: EDID has only 11 bits for active resolution dimensions, it means that the maximum pixel number is 4095.

DisplayID extension supports high resolution displays and tile mode. This interface provides easy and user-friendly input of the Display ID information. `#displayid`

The screenshot shows the EDID Editor window with a sidebar on the left containing various categories like 3rd Descriptor Field, 4th Descriptor Field, CEA Extension, General, Video Data, Audio Data, etc. The main area is titled 'Tiled Display Topology Block' and contains the following configuration options:

Single Physical Device	<input checked="" type="radio"/>
Bezel Information Available	<input type="radio"/>
General Behaviour	Can not be described
Specific Behaviour	Can not be described
Total number of Horizontal Tiles	1
Total number of Vertical Tiles	1
Horizontal Tile Location	1
Vertical Tile Location	1
Horizontal Size (pixel)	640
Vertical Size (line)	480
Pixel Multiplier	0
Top Bezel Size (pixel)	0
Bottom Bezel Size (pixel)	0
Right Bezel Size (pixel)	0
Left Bezel Size (pixel)	0
Tiled Display Vendor	LWR
Tiled Display Product Code	0
Tiled Display Serial Number	0

EDID Editor window

7.9. Settings Menu

7.9.1. Overview

Settings menu - Overview tab

The most important hardware and software related information can be found on this tab: hardware and firmware version, serial numbers, endpoint statistics, temperatures, operation time, and voltage information. **Device label** can be changed to unique description. `#firmwareversion #label #devicelabel #license #producttype #serialnumber`

Licenses

MX2M-FR24R matrix switcher can be purchased with no PSU redundancy. In this case only one PSU drawer is installed with a power supply unit (Power Drawer 1, Primary), and the **Single PSU License** is installed on the matrix, which results in the Power Drawer 2 being unable to accept the second PSU drawer. Customers have the possibility of purchasing a code that makes the Single PSU License inactive. For more details, please contact sales@lightware.com.

7.9.2. Network

Settings menu - Network tab

Static IP address and DHCP (dynamic IP address) settings can be set on this tab. Always press the **Apply settings** button to save changes.

Factory default settings of the matrix can be recalled with a dedicated button. See the factory default values in the [Factory Default Settings](#) section. `#network #dhcp #ipaddress`

7.9.3. System Log

The screenshot shows the MX2M System Log tab. The main area contains a table with the following columns: Index, Time, Level, Host, Identification, and Message. The table lists 20 log entries starting from index 1/1167. The messages include system boot logs, kernel messages, and memory management information. On the right side, there is a 'Column Switcher' section with checkboxes for Time, Level, Host, Identification, and Message, all of which are checked. Below this is a 'Summary' section showing counts for Info (0), Notice (0), Warning (0), and Error (0). At the bottom right, there is an 'Export Full System Log' button.

Index	Time	Level	Host	Identification	Message
1/1167	--			Thu	29:44 UTC, end at Tue 2020-07-21 10:58:39 UTC. --
2/1167	Jul 20 09:53:22		mx2m	kernel	Booting Linux on physical CPU 0x0
3/1167	Jul 20 09:53:22		mx2m	kernel	Initializing cgroup subsys cpu
4/1167	Jul 20 09:53:22		mx2m	kernel	Initializing cgroup subsys cpucct
5/1167	Jul 20 09:53:22		mx2m	kernel	Linux version 4.1.44-g969d83c4a-dirty (jenkins@f5750190fcea) (gcc version 6.2.0 (cross-tool-NG cross-tool-ng-1.22.0-321-g699a54d)) #1 SMP Wed Jun 24 09:38:32 UTC 2020
6/1167	Jul 20 09:53:22		mx2m	kernel	CPU: ARMv7 Processor [412fc09a] revision 10 (ARMv7), cr-10c5387d
7/1167	Jul 20 09:53:22		mx2m	kernel	CPU: PIPT / VIPT nonaliasing data cache, VIPT aliasing instruction cache
8/1167	Jul 20 09:53:22		mx2m	kernel	Machine model: Lightware MX2M
9/1167	Jul 20 09:53:22		mx2m	kernel	Reserved memory: created CMA memory pool at 0x14000000, size 128 MIB
10/1167	Jul 20 09:53:22		mx2m	kernel	Reserved memory: initialized node linux.cma, compatible id shared-dma-pool
11/1167	Jul 20 09:53:22		mx2m	kernel	Memory policy: Data cache writealloc
12/1167	Jul 20 09:53:22		mx2m	kernel	On node 0 totalpages: 65536
13/1167	Jul 20 09:53:22		mx2m	kernel	free_area_init_node: node 0, pgdat 8094f8c0, node_mem_map 8fdb7000
14/1167	Jul 20 09:53:22		mx2m	kernel	Normal zone: 512 pages used for memmap
15/1167	Jul 20 09:53:22		mx2m	kernel	Normal zone: 0 pages reserved
16/1167	Jul 20 09:53:22		mx2m	kernel	Normal zone: 65536 pages, LIFO batch:15
17/1167	Jul 20 09:53:22		mx2m	kernel	PERCPU: Embedded 12 pages/cpu @8fd7e000 s16588 r8192 d24372 u49152
18/1167	Jul 20 09:53:22		mx2m	kernel	pcpu-alloc: s16588 r8192 d24372 u49152 alloc-12*4096
19/1167	Jul 20 09:53:22		mx2m	kernel	pcpu-alloc: [0] 0 [0] 1
20/1167	Jul 20 09:53:22		mx2m	kernel	Built 1 zonelists in Zone order, mobility grouping on. Total pages: 65024

Settings menu - System Log tab

All matrix related notifications are listed in the System log tab, which are grouped into four categories: info, notice, warning, and error. The categories are summarized on the right side of the tab in the **Summary** section. The list can be customized with the **Column Switchers** by turning the following columns on or off: Time, Level, Identification, and Message.

All system log tracks can be saved to the control computer with the **Export full system log** button. *#log*

INFO: Please always download the system logs and send them to the Lightware Support Team (support@lightware.com) for the most effective collaboration in case of a troubleshooting issue.

7.9.4. System

The screenshot shows the MX2M System Settings menu. It is divided into several sections:

- Date / time settings:** Includes a date selector (2020-07-21), time zone (12), and other settings. A 'Set' button is present. There is also a 'Synchronize with the Local Computer' button.
- Load factory defaults:** A 'Factory Defaults' button.
- Save and restore system settings:** Includes a 'Save system settings' section with a 'Save' button, and a 'Reboot device' section with a 'Reset' button.
- Other options:** A 'Select a saved settings file to upload' field, a 'Keep current network settings' checkbox, and a 'Restore' button.

Settings menu - System tab

The following functions are available under the System tab:

- **Date / time settings** - system time can be set manually or can be synchronized with your control device. *#time #date*
- **Save and restore system settings** *#backup #restore*
 - **Save system settings** - clicking on the **Save** button saves the actual configuration of the matrix to a file.
 - **Restore** - select a backup file of the matrix on your computer and select the **Restore** button to load it. The configuration settings saved in the file are applied immediately.
- **Load factory defaults** - recalling factory default settings and values for the matrix. All factory default settings are listed in the [Factory Default Settings](#) section. *#factory*
- **Reboot device** - the matrix switcher reboots, it is the same as disconnecting the power source and reconnecting it again. *#reboot #restart #reset*

7.10. Terminal Window

Select the Settings / Terminal menu to open the Terminal window. `#terminal #advancedview`

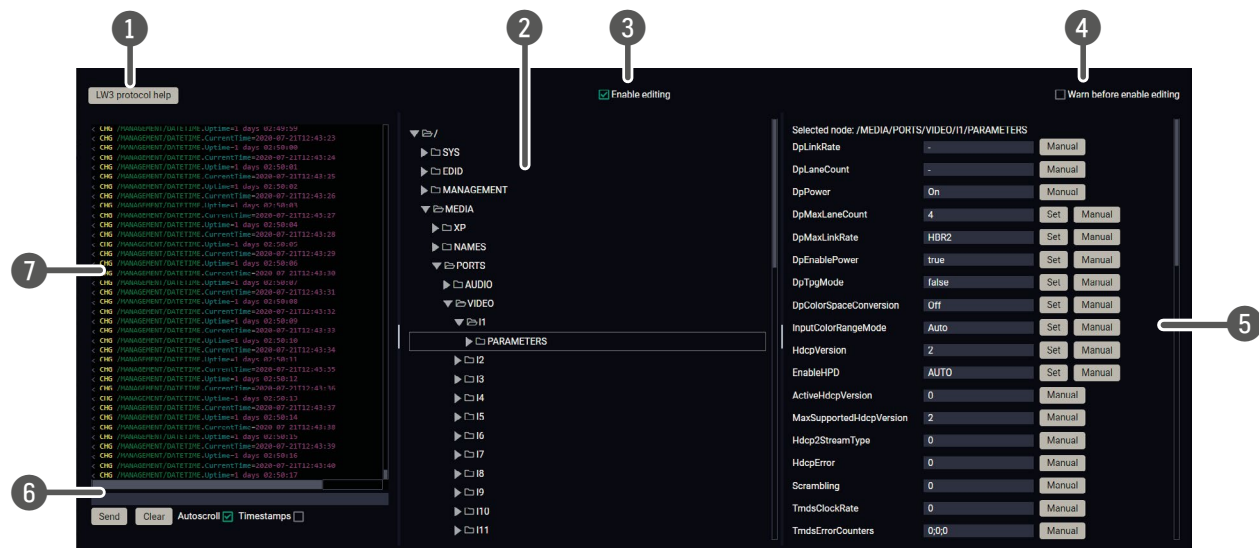

- 1 **LW3 protocol help** Pushing the button opens a help window that describes the most important information about LW3 protocol commands in HTML format.
- 2 **Protocol tree** LW3 protocol tree; select an item to see its content.
- 3 **Edit mode** The default appearance is the read-only mode. If you want to modify the values or parameters, tick the option. You will be prompted to confirm your selection.
- 4 **Warning mode** If this box checked in, a warning window pops up when you enable Edit mode.
- 5 **Node list** Correspondent parameters and nodes are shown that are connected to the selected item in the protocol tree.
Manual button: Manual (short description) of the node can be called and displayed in the terminal window.
Set button: Saves the value/parameter typed in the textbox.
Call button: Calls the method, e.g. reloads factory default settings.
- 6 **Command line** Type the desired command and execute it with the **Send** button. Clear all current commands and responses in the Terminal window by the **Clear** button.
- 7 **Terminal window** Commands and responses with time and date are listed in this window. Sent commands start with '`>`' character, received responses start with '`<`' character. The color of each item depends on the type of the command and response. The content of the window can be emptied by the **Clear** button. If the **Autoscroll** option is ticked, the list is scrolled automatically when a new line is added.

7.11. Health Menu

7.11.1. Overview

Health menu - Overview tab

All general information about the matrix frame and the installed I/O boards is available in the Overview tab of the Health menu. The firmware package version, error or warning messages, the list of installed I/O boards grouped by types and the serial and part numbers can be seen on this tab. `#health #status #producttype`

The **Overall Health** indicator shows whether there is any warning or error message in the system:

Icon	Type	Description
	OK	No active warning or error level log entry exists for the system or a device seated in the system.
	Warning	Active warning level log entry exists and no active error level log entry exists for the system or a device seated in the system.
	Error	Active error level log entry exists for the system or a device seated in the system.

`#health #status #systemmonitor`

7.11.2. Frame

The screenshot shows the MX2M Health Status page with the 'Frame' tab selected. The overall health is 'OK'. The page is divided into several sections:

- SOFTWARE PACKAGE VERSION:** v1.1.0b13
- AC POWER LINE REDUNDANCY:** PSU drawer 2 not inserted (Warning icon)
- FRAME VOLTAGES:**
 - Voltage (1.05V): 1.03 V
 - Voltage (1.2V): 1.20 V
 - Voltage (1.5V): 1.48 V
 - Voltage (3.3V): 3.32 V
 - Voltage (5V): 5.06 V
- FRAME TEMPERATURES:**
 - Temperature (CPU): 37.26°C
 - Temperature XPoint 1: 42.50°C
 - Temperature XPoint 2: 42.50°C
 - Temperature XPoint Ext: 42.50°C
- FAN SPEEDS:**
 - Fan 1: 3842.05 RPM
 - Fan 2: 3735.73 RPM
 - Fan 3: 3694.83 RPM

Health menu - Frame tab

The most important information about the matrix frame is available on the Frame tab. The firmware package version, AC power line redundancy, frame voltages, frame temperatures and the fan speeds can be checked.

7.11.3. Aux Slots

The screenshot shows the MX2M Health Status page with the 'Aux Slots' tab selected. The overall health is 'OK'. The page displays details for four auxiliary boards:

- AUX BOARD 1:** Board Status: Operational; Type: MX2M-AUX-8AUDIO; Temperature (CPU): 24.10°C; Voltage (5V): 5.01 V; Voltage (3.3V): 3.30 V; Voltage (1.8V): 1.80 V; Voltage (1V): 0.99 V
- AUX BOARD 2:** Board Status: Not present
- AUX BOARD 3:** Board Status: Not present
- AUX BOARD 4:** Board Status: Not present

Health menu - Aux Slots tab

The most important information about the auxiliary boards grouped by the board slots is available on the Aux Slots tab. The type of the installed I/O board, the status of the board, the temperature and voltage information can be checked on the tab.

INFO: See the details about the location of the AUX board slots in the [Layout of the Input/Output Board Slots and Power Drawer Slots](#) section.

7.11.4. Input Slots

HEALTH STATUS OVERALL HEALTH: ✔

Overview Frame Aux Slots **Input Slots** Output Slots PSU Drawer Slots Falling Devices

INPUT SLOTS

INPUT BOARD 1	INPUT BOARD 2	INPUT BOARD 3
Board Status: Operational	Board Status: Operational	Board Status: Operational
Type: MX2M-4HDMI20-IB	Type: MX2M-DH-4DP12-IB	Type: MX2M-4OPTJ-IB
Temperature (CPU): 30.68°C ✔	Voltage (5V): 5.02 V	Temperature (CPU): 29.71°C ✔
Voltage (5V): 4.99 V	Voltage (3.3V): 3.32 V	Temperature 1: 0.00°C ✔
Voltage (3.3V): 3.30 V	Voltage (3.3V): 3.33 V	Temperature 2: 28.00°C ✔
Voltage (1.8V): 1.81 V	Voltage (1.8V): 1.80 V	Voltage (5V): 4.96 V
Voltage (1V): 1.02 V	Voltage (1.2V): 1.20 V	Voltage (3.3V): 3.30 V
Voltage (1V): 1.00 V	Voltage (1V): 1.01 V	Voltage (1.8V): 1.79 V
	Voltage (1V): 1.00 V	Voltage (1V): 1.01 V
	Temperature (CPU): 32.63°C ✔	Voltage (1V): 0.99 V
INPUT BOARD 4	INPUT BOARD 5	INPUT BOARD 6
Board Status: Not present	Board Status: Not present	Board Status: Not present

Health menu - Input Slots tab

The most important information about the input boards grouped by the board slots is available on the Input Slots tab. The type of the installed I/O board, the status of the board, the temperature and voltage information can be checked on the tab.

INFO: See the details about the location of the input board slots in the [Layout of the Input/Output Board Slots and Power Drawer Slots](#) section.

7.11.5. Output Slots

HEALTH STATUS OVERALL HEALTH: ✔

Overview Frame Aux Slots **Input Slots** Output Slots PSU Drawer Slots Falling Devices

INPUT SLOTS

INPUT BOARD 1	INPUT BOARD 2	INPUT BOARD 3
Board Status: Operational	Board Status: Operational	Board Status: Operational
Type: MX2M-4HDMI20-IB	Type: MX2M-DH-4DP12-IB	Type: MX2M-4OPTJ-IB
Temperature (CPU): 30.68°C ✔	Voltage (5V): 5.02 V	Temperature (CPU): 29.71°C ✔
Voltage (5V): 4.99 V	Voltage (3.3V): 3.32 V	Temperature 1: 0.00°C ✔
Voltage (3.3V): 3.30 V	Voltage (3.3V): 3.33 V	Temperature 2: 28.00°C ✔
Voltage (1.8V): 1.81 V	Voltage (1.8V): 1.80 V	Voltage (5V): 4.96 V
Voltage (1V): 1.02 V	Voltage (1.2V): 1.20 V	Voltage (3.3V): 3.30 V
Voltage (1V): 1.00 V	Voltage (1V): 1.01 V	Voltage (1.8V): 1.79 V
	Voltage (1V): 1.00 V	Voltage (1V): 1.01 V
	Temperature (CPU): 32.63°C ✔	Voltage (1V): 0.99 V
INPUT BOARD 4	INPUT BOARD 5	INPUT BOARD 6
Board Status: Not present	Board Status: Not present	Board Status: Not present

Health menu - Output Slots tab

The most important information about the output boards grouped by the board slots is available on the Output Slots tab. The type of the installed I/O board, the status of the board, the temperature and voltage information can be checked on the tab.

INFO: See the details about the location of the output board slots in the [Layout of the Input/Output Board Slots and Power Drawer Slots](#) section.

7.11.6. PSU Drawer Slots

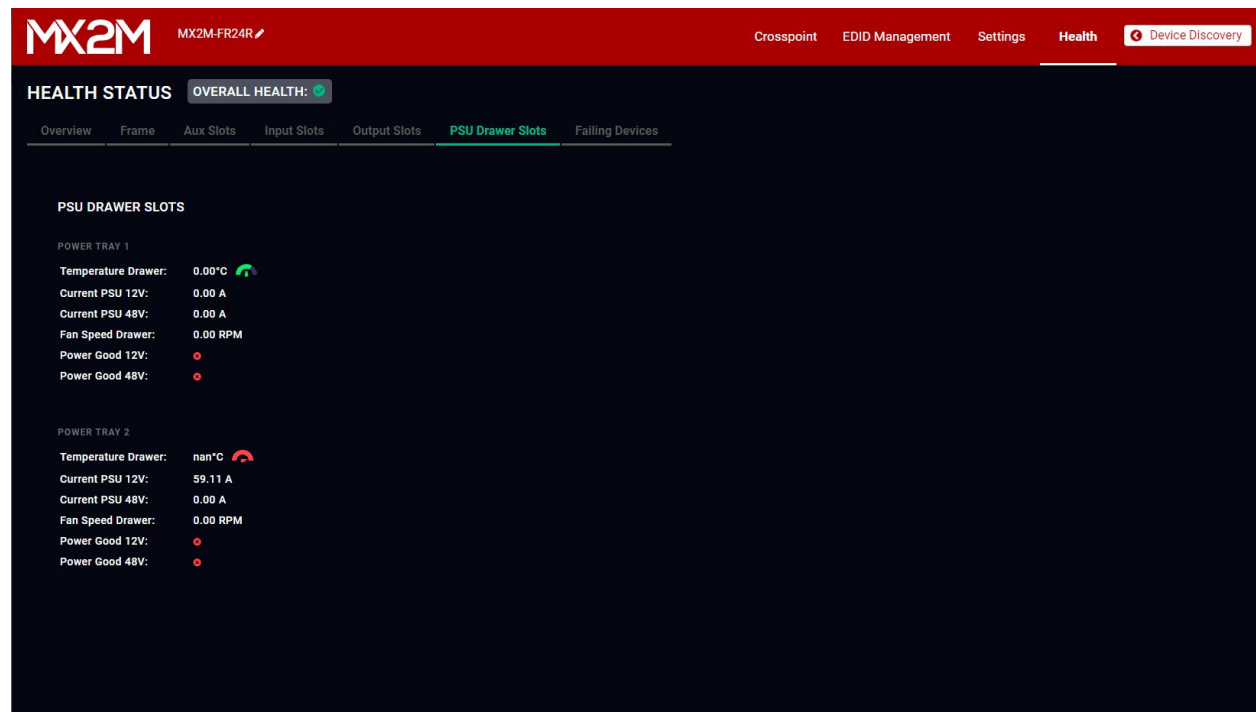

Health menu - PSU Drawer Slots tab

The most important information about the PSU drawers grouped by the power drawer slots is available on the PSU Drawer Slots tab. The temperature, current, voltage and fan speed information can be checked on the tab.

INFO: See the details about the numbering of the PSU drawer slots in the [Layout of the Input/Output Board Slots and Power Drawer Slots](#) section.

7.11.7. Failing Devices

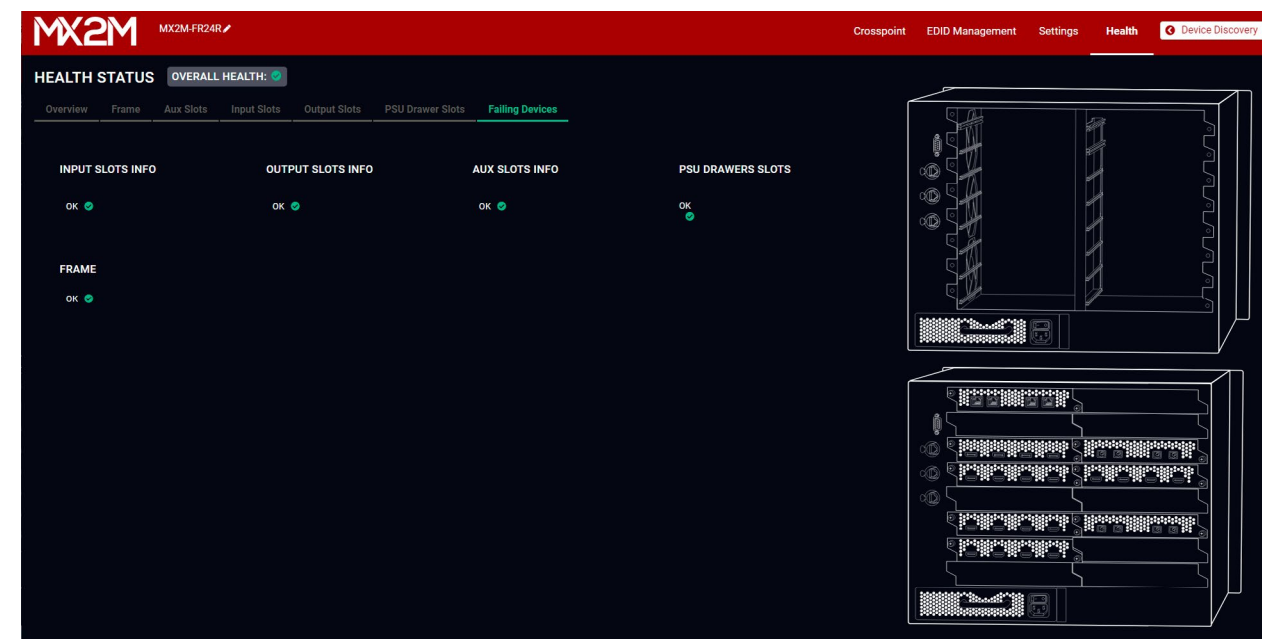

Health menu - Failing Devices tab

The most important status information about the matrix frame and the installed I/O boards is available on the Failing Devices tab.

Overall Health Info about the I/O Board Slots

The indicators show whether there is any warning or error message in the system:

Icon	Type	Description
✓	OK	No active warning or error level log entry exists for the system or a device seated in the system.
⚠	Warning	Active warning level log entry exists and no active error level log entry exists for the system or a device seated in the system.
!	Error	Active error level log entry exists for the system or a device seated in the system.

Matrix Drawing

The drawing of the matrix shows the recent installation of the matrix frame, including the I/O boards with the slots where they are installed.

8

LW3 Programmers' Reference

The device can be controlled through Lightware 3 (LW3) protocol commands to ensure compatibility with other Lightware products. The supported LW3 commands are described in this chapter.

▶ Overview	77
▶ Instructions for the Terminal Application Usage	77
▶ Protocol Rules	77
▶ System Commands	80
▶ I/O Board Management	82
▶ Video Switching and Crosspoint Settings	83
▶ Audio Switching and Crosspoint Settings	85
▶ Video Source Port Settings - HDMI / OPTJ	88
▶ Video Source Port Settings - DP	88
▶ Video Source Port Settings - TPX	91
▶ Video Destination Port Settings - HDMI / OPTJ / TPX	91
▶ Analog Audio Port Properties	93
▶ Dante® Audio Settings	95
▶ System Monitoring Commands	96
▶ Preset Handling	99
▶ EDID Management	100
▶ Health Status Monitoring Commands	101
▶ Network Configuration	106
▶ RS-232 Port Configuration	107
▶ Sending CEC Commands	109
▶ Firmware Updating of the I/O Boards	111
▶ LW3 Protocol Commands - Quick Summary	113

8.1. Overview

The Lightware Protocol #3 (LW3) is implemented in almost all new Lightware devices (matrix switchers, signal extenders and distribution amplifiers) since 2012. The protocol is ASCII-based and all commands are terminated with a carriage return (Cr, '\r') and line feed (Lf, '\n') pair. It is organized as a tree structure that provides outstanding flexibility and user-friendly handling with 'nodes', 'properties' and 'methods'. The **Advanced View** of the Lightware Device Controller software is the perfect tool for browsing and learning how the LW3 protocol can be used in practice.

8.2. Instructions for the Terminal Application Usage

Terminal Application

The LW3 protocol commands can be applied to the receiver using a terminal application. You need to install one of them on your control device, for example **PuTTY** or **CLI**. `#terminal`

Establishing Connection

Follow the steps for establishing connection to the receiver:

- Step 1.** Connect the receiver to a LAN over Ethernet (see the details in the [Connecting Steps](#) section).
- Step 2.** Open the terminal application (e.g. PuTTY).
- Step 3.** Add the **IP address** of the device (the default IP setting is the DHCP (dynamic IP address)) and the **port number (6107)**.
- Step 4.** Select the **Raw** connection type, and open the connection.

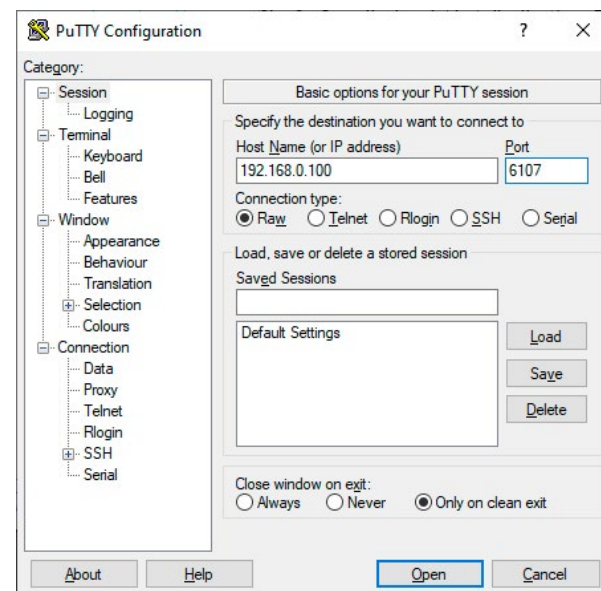

Once the terminal window is opened, you can enter the LW3 protocol commands, which are listed in the following sections.

```

172.24.1.163 - PuTTY
GET /.ProductName
pr /.ProductName=MX2M-FR24R
GET /MANAGEMENT/UID/PACKAGE.Version
pr /MANAGEMENT/UID/PACKAGE.Version=v1.0.0b20
GET /MANAGEMENT/DATETIME.CurrentTime
pr /MANAGEMENT/DATETIME.CurrentTime=2020-07-24T10:00:11
GET /SYS/OB1.Status
pr /SYS/OB1.Status=Not present
GET /SYS/OB2.Status
pr /SYS/OB2.Status=Not present
GET /SYS/OB3.Status
pr /SYS/OB3.Status=Operational

```

LW3 protocol command communication in a terminal window

8.3. Protocol Rules

8.3.1. LW3 Tree Structure and Command Structure (examples)

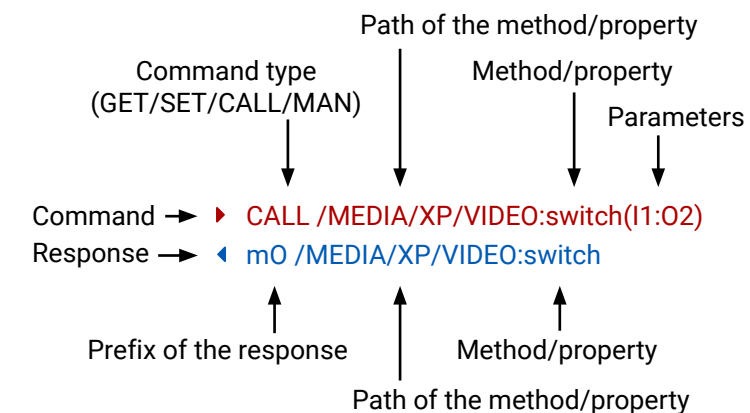
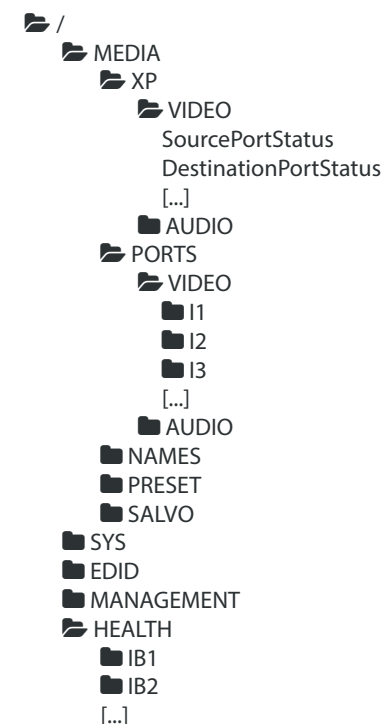

8.3.2. General Rules

- All names and parameters are **case-sensitive**.
- The nodes are separated by a slash ('/') character.
- The node name can contain the elements of the English alphabet and numbers.
- Use the **TCP port no. 6107** when using LW3 protocol over Ethernet.
- When a command is issued by the device, the received response cannot be processed by the CPU.
- The node paths describe the exact location of the node, listing each parent node up to the root.

8.3.3. Command Types

GET command

The **GET** command can be used to get the child nodes, properties and methods of a specific node. It can also be used to get the value of a property. Use the dot character (.) when addressing a property:

- ▶ **GET /.SerialNumber**
- ◀ **pr /.SerialNumber=87654321**

GETALL command

The **GETALL** command can be used to get all child nodes, properties and methods of a node with one command.

- ▶ **GETALL /MEDIA/XP**
- ◀ **n- /MEDIA/XP/VIDEO**
- ◀ **n- /MEDIA/XP/AUDIO**
- ◀ **m- /MEDIA/XP:MultiLayer_Connect**
- ◀ **m- /MEDIA/XP:MultiLayer_Switch**
- ◀ **m- /MEDIA/XP:MultiLayer_SwitchAll**
- ◀ **m- /MEDIA/XP:MultiLayer_SwitchMulti**

SET command

The **SET** command can be used to modify the value of a property. Use the dot character (.) when addressing the property:

- ▶ **SET /MEDIA/PORTS/VIDEO/I1/PARAMETERS.HdcpVersion=2**
- ◀ **pw /MEDIA/PORTS/VIDEO/I1/PARAMETERS.HdcpVersion=2**

CALL command

A method can be invoked by the **CALL** command. Use the colon character (:) when addressing the method:

- ▶ **CALL /EDID:switchAll(F147)**
- ◀ **mO /EDID:switchAll**

MAN command

The manual is a human readable text that describes the syntax and provides a hint on how to use the primitives. For every node, property and method in the tree there is a manual; type the MAN command to get the manual:

- ▶ **MAN /MEDIA/PORTS/VIDEO/O1/PARAMETERS.AudioSource**
- ◀ **pm /MEDIA/PORTS/VIDEO/O1/PARAMETERS.AudioSource ["Hdmi" | "AudioLayer" | "Off"] Sets the source of the embedded audio stream**

8.3.4. Prefix Summary

DEFINITION: The prefix is a 2-character-long code that describes the type of the response.

The following prefixes are defined in the LW3 protocol:

Prefix	Description	Prefix	Description
n-	a node	pm	a manual for the property
nE	an error for a node	m-	a method
nm	a manual for a node	mO	a response after a successful method execution
pr	a read-only property	mF	a response after a failed method execution
pw	read-write property	mE	an error for a method
pE	an error for the property	mm	a manual for a method

8.3.5. Error Messages

There are several error messages defined in the LW3 protocol, all of them have a unique error number.

- ▶ **CALL /MEDIA/XP/VIDEO:lockSource(IA)**
- ◀ **mE /MEDIA/XP/VIDEO:lockSource %E006: Illegal operation**

8.3.6. Escaping

DEFINITION: An escape sequence is a sequence of characters that does not represent itself when used inside a character or string literal, but is translated into another character or a sequence of characters.

Property values and method parameters can contain characters that are used as control characters in the protocol. They must be escaped. The escape character is the backslash ('\'), and escaping means injecting a backslash before the character that should be escaped (like in C language).

Control characters are the following: \ { } # % () \r \n \t

8.4. System Commands

8.4.1. Querying the Product Name

The name of the product is a read-only parameter and cannot be modified.

Command and Response *#producttype*

- ▶ GET /.ProductName
- ◀ pr /.ProductName=<Product_name>

Example

- ▶ GET /.ProductName
- ◀ pr /.ProductName=MX2M-FR24R

8.4.2. Setting the Device Label

INFO: The device label can be changed to a custom text in the [Overview](#) tab of the LDC software. This writable parameter is not the same as the ProductName parameter.

Command and Response *#devicelabel #label*

- ▶ SET /MANAGEMENT/LABEL/DeviceLabel=<Custom_name>
- ◀ pw /MANAGEMENT/LABEL/DeviceLabel=<Custom_name>

The Device Label can be 39 characters long and ASCII characters are allowed. Longer names are truncated.

Example

- ▶ SET /MANAGEMENT/LABEL.DeviceLabel=MX2M_Conference
- ◀ pw /MANAGEMENT/LABEL.DeviceLabel=MX2M_Conference

8.4.3. Querying the Serial Number

Command and Response *#serialnumber*

- ▶ GET /.SerialNumber
- ◀ pr /.SerialNumber=<serial_number>

Example

- ▶ GET /.SerialNumber
- ◀ pr /.SerialNumber=87654321

8.4.4. Querying the Firmware Version

Command and Response *#firmwareversion*

- ▶ GET /MANAGEMENT/UID/PACKAGE.Version
- ◀ pr /MANAGEMENT/UID/PACKAGE.Version=<firmware_version>

Example

- ▶ GET /MANAGEMENT/UID/PACKAGE.Version
- ◀ pr /MANAGEMENT/UID/PACKAGE.Version=1.0.0b20

8.4.5. Querying the Date and Time of the System

The query returns with the current date and time that is set in the matrix. The format is based on the ISO 8601 standard.

Command and Response *#time #date*

- ▶ GET /MANAGEMENT/DATETIME.CurrentTime
- ◀ pr /MANAGEMENT/DATETIME.CurrentTime=<date_time>

Parameters

Parameter	Description	Formula
<date_time>	Current date and time	YYYY-MM-DDTHH:MM:SS

Example

- ▶ GET /MANAGEMENT/DATETIME.CurrentTime
- ◀ pr /MANAGEMENT/DATETIME.CurrentTime=2020-09-01T17:38:37

8.4.6. Setting the Date and Time Manually

The date and time format is based on the ISO 8601 standard.

Command and Response

- ▶ CALL /MANAGEMENT/DATETIME:setTime=<date_time>
- ◀ mO /MANAGEMENT/DATETIME:setTime=

Parameters

Parameter	Description	Formula
<date_time>	Current date and time	YYYY-MM-DDTHH:MM:SS

Example

- ▶ CALL /MANAGEMENT/DATETIME:setTime=2020-12-24T20:00:15
- ◀ mO /MANAGEMENT/DATETIME:setTime=

8.4.7. Setting the Brightness of the LCD Screen

Command and Response

- ▶ SET /SYS/CECU/LCD.Brightness=<parameter>
- ◀ pw /SYS/CECU/LCD.Brightness=<parameter>

Parameters

The <parameter> of display brightness can be set between values 0 and 10.

Example

- ▶ SET /SYS/CECU/LCD.Brightness=5
- ◀ pw /SYS/CECU/LCD.Brightness=5

8.4.8. Control Lock of the LCD Menu

Enable/disable the operation of the jog dial control knob and the LCD menu control.

Command and Response #controllock

- ▶ SET /SYS/CECU/LCD.ControlLock=<logical_value>
- ◀ pw /SYS/CECU/LCD.ControlLock=<logical_value>

Parameters

Identifier	Parameter description	Value	Value description
<mode>	Control lock mode	true	Enabled
		false	Disabled

Example

- ▶ SET /SYS/CECU/LCD.ControlLock=true
- ◀ pw /SYS/CECU/LCD.ControlLock=true

8.4.9. Adding License

Command and Response #license

- ▶ CALL /MANAGEMENT/LICENSE:addLicense()
- ◀ mO /MANAGEMENT/LICENSE:addLicense=

Example

- ▶ CALL /MANAGEMENT/LICENSE:addLicense()
- ◀ mO /MANAGEMENT/LICENSE:addLicense=

8.4.10. Removing License

Command and Response #license

- ▶ CALL /MANAGEMENT/LICENSE:removeLicense()
- ◀ mO /MANAGEMENT/LICENSE:removeLicense=

Example

- ▶ CALL /MANAGEMENT/LICENSE:removeLicense()
- ◀ mO /MANAGEMENT/LICENSE:removeLicense=

8.4.11. Software Resetting the Device

The core application of the matrix can be restarted.

Command and Response #softreset

- ▶ CALL /SYS:softReset()
- ◀ mO /SYS:softReset=

Example

- ▶ CALL /SYS:softReset()
- ◀ mO /SYS:softReset=

8.4.12. Rebooting the Device

The device can be restarted – the current connections and the AV signal transmission will be terminated.

Command and Response #restart #reboot #reset

- ▶ CALL /SYS:reset()
- ◀ mO /SYS:reset=

Example

- ▶ CALL /SYS:reset()
- ◀ mO /SYS:reset=

8.4.13. Restoring the Factory Default Settings

Command and Response #factory

- ▶ CALL /SYS:factoryDefaults()
- ◀ mO /SYS:factoryDefaults=

Example

- ▶ CALL /SYS:factoryDefaults()
- ◀ mO /SYS:factoryDefaults=

The device is restarted, current connections are terminated, and the [Factory Default Settings](#) are restored.

8.5. I/O Board Management

8.5.1. Querying the Status of a Board

The query returns the actual status of the selected I/O board in the matrix frame.

Command and Response

- ▶ GET /SYS/<board>.Status
- ◀ pr /SYS/<board>.Status=<status>

Parameters

Identifier	Parameter description	Value	Value description
<board>	The identifier of the board.	IB1...IB6	Input board ID, the values can be IB1, IB2, IB3, IB4, IB5 or IB6.
		OB1...OB6	Output board ID, the values can be OB1, OB2, OB3, OB4, OB5 or OB6.
		LS1...LS4	Auxiliary (LS - Low Speed) board ID, the values can be LS1, LS2, LS3, or LS4.
<status>	Current status of the I/O board	No power	Board is present but not powered.
		Not present	Board is not present.
		Seated	Board is seated into the slot.
		Connecting	Connecting to the CPU.
		Connected	Connected to the CPU but not initialized yet.
		Initializing	Under initialization.
		Operational	Board is operational and ready for use.
		Reset	Board is rebooting.
		Debug	Board is in debug mode.
		FirmwareUpgradeEthernet	The firmware of the board is being updated by the matrix frame.
		BootloadMode	Board is in bootload (firmware update) mode, which might happen after an unsuccessful firmware update procedure. Restarting the firmware update procedure is recommended.
		InWrongSlot	The board is seated to the wrong slot. See the layout of the I/O board slot in the Board Installation and Handling section.
Unknown	The status of board is unknown. Reseating of the board is recommended.		

Example

- ▶ GET /SYS/OB1.Status
- ◀ pr /SYS/OB1.Status=Operational

8.5.2. Querying the Number of Seated I/O Boards

The query returns the number of the seated I/O boards in the matrix frame, including IB, OB, and AUX (Low Speed) boards.

Command and Response

- ▶ GET /SYS/UPDATE.NumberOfBoards
- ◀ pr /SYS/UPDATE.NumberOfBoards=<number>

Example

- ▶ GET /SYS/UPDATE.NumberOfBoards
- ◀ pr /SYS/UPDATE.NumberOfBoards=7

8.5.3. Querying the List of Seated I/O Boards

The query returns the list of the seated I/O boards in the matrix frame, including IB, OB, and AUX (Low Speed) boards.

Command and Response

- ▶ GET /SYS/UPDATE.BoardsInSeatedState
- ◀ pr /SYS/UPDATE.BoardsInSeatedState=<board_slot1>;<board_slot2>;...<board_slotX>

Example

- ▶ GET /SYS/UPDATE.BoardsInSeatedState
- ◀ pr /SYS/UPDATE.BoardsInSeatedState=LS1;LS2;IB2;IB4;OB1;OB2;OB3;OB4;OB5

8.5.4. Querying the List of Operational I/O Boards

The query returns the list of the operational I/O boards in the matrix frame, including IB, OB, and AUX (Low Speed) boards.

Command and Response

- ▶ GET /SYS/UPDATE.BoardsInOperationalState
- ◀ pr /SYS/UPDATE.BoardsInOperationalState=<board_slot1>;<board_slot2>;...<board_slotX>

Example

- ▶ GET /SYS/UPDATE.BoardsInOperationalState
- ◀ pr /SYS/UPDATE.BoardsInOperationalState=LS1;LS2;IB2;IB4;OB1;OB2;OB3;OB4;OB5

8.6.2. Switching an Input to an Output

Command and Response *#switch #crosspoint*

- ▶ CALL /MEDIA/XP/VIDEO:switch(<in>:<out>)
- ◀ mO /MEDIA/XP/VIDEO:switch=

Example

- ▶ CALL /MEDIA/XP/VIDEO:switch(I4:O1)
- ◀ mO /MEDIA/XP/VIDEO:switch=

8.6.3. Disconnecting the Output from any Input

Command and Response

- ▶ CALL /MEDIA/XP/VIDEO:switch(0:<out>)
- ◀ mO /MEDIA/XP/VIDEO:switch=

Example

- ▶ CALL /MEDIA/XP/VIDEO:switch(0:O1)
- ◀ mO /MEDIA/XP/VIDEO:switch=

8.6.4. Switching an Input to All Outputs

Command and Response

- ▶ CALL /MEDIA/XP/VIDEO:switchAll(<in>)
- ◀ mO /MEDIA/XP/VIDEO:switchAll=

Example

- ▶ CALL /MEDIA/XP/VIDEO:switchAll(I1)
- ◀ mO /MEDIA/XP/VIDEO:switchAll=

TIPS AND TRICKS: All output ports can be disconnected with the '0' value:
CALL /MEDIA/XP/VIDEO:switchAll(0).

8.6.5. Multiple Switching

The whole crosspoint can be set by sending one command as follows.

Command and Response

- ▶ CALL /MEDIA/XP/VIDEO:switchMulti(<out1_source>;<out2_source>;...;<out8_source>)
- ◀ mO /MEDIA/XP/VIDEO:switchMulti=

The source is not required to be set on all output ports (see the **Example2**).

Parameters

The <out#_source> parameters mean the output ports one after the other. The value of the parameter shows the input port switched to the given output port.

Example1

- ▶ CALL /MEDIA/XP/VIDEO:switchMulti(I1;I2;I3;I4;I5;I6;I7;I8)
- ◀ mO /MEDIA/XP/VIDEO:switchMulti=

Example2

- ▶ CALL /MEDIA/XP/VIDEO:switchMulti(I1;I2;;;I5)
- ◀ mO /MEDIA/XP/VIDEO:switchMulti=

8.6.6. Muting a Video Input

Command and Response *#mute*

- ▶ CALL /MEDIA/XP/VIDEO:muteSource(<in>)
- ◀ mO /MEDIA/XP/VIDEO:muteSource=

Example

- ▶ CALL /MEDIA/XP/VIDEO:muteSource(I1)
- ◀ mO /MEDIA/XP/VIDEO:muteSource=

8.6.7. Unmuting a Video Input

Command and Response *#unmute*

- ▶ CALL /MEDIA/XP/VIDEO:unmuteSource(<in>)
- ◀ mO /MEDIA/XP/VIDEO:unmuteSource=

Example

- ▶ CALL /MEDIA/XP/VIDEO:unmuteSource(I1;I3)
- ◀ mO /MEDIA/XP/VIDEO:unmuteSource=

8.7.2. Switching an Input to an Output

Command and Response *#switch #crosspoint*

- ▶ CALL·/MEDIA/XP/AUDIO:switch(<in>:<out>)
- ◀ mO·/MEDIA/XP/AUDIO:switch=

Example

- ▶ CALL /MEDIA/XP/AUDIO:switch(I4:O1)
- ◀ mO /MEDIA/XP/AUDIO:switch=

8.7.3. Disconnecting the Output from any Input

Command and Response

- ▶ CALL·/MEDIA/XP/AUDIO:switch(0:<out>)
- ◀ mO·/MEDIA/XP/AUDIO:switch=

Example

- ▶ CALL /MEDIA/XP/AUDIO:switch(0:O1)
- ◀ mO /MEDIA/XP/AUDIO:switch=

8.7.4. Switching an Input to All Outputs

Command and Response

- ▶ CALL·/MEDIA/XP/AUDIO:switchAll(<in>)
- ◀ mO·/MEDIA/XP/AUDIO:switchAll=

Example

- ▶ CALL /MEDIA/XP/AUDIO:switchAll(I1)
- ◀ mO /MEDIA/XP/AUDIO:switchAll=

TIPS AND TRICKS: All output ports can be disconnected with the '0' value:

- ▶ CALL /MEDIA/XP/AUDIO:switchAll(0).

8.7.5. Multiple Switching

The whole crosspoint can be set by sending one command as follows. *#switch #crosspoint*

Command and Response

- ▶ CALL·/MEDIA/XP/AUDIO:switchMulti(<out1_source>;<out2_source>;...;<out8_source>)
- ◀ mO·/MEDIA/XP/AUDIO:switchMulti=

The source is not required to be set on all output ports (see the **Example2**).

Parameters

The <out#_source> parameters mean the output ports one after the other. The value of the parameter shows the input port switched to the given output port.

Example1

- ▶ CALL /MEDIA/XP/AUDIO:switchMulti(I1;I2;I3;I4;I5;I6;I7;I8)
- ◀ mO /MEDIA/XP/AUDIO:switchMulti=

Example2

- ▶ CALL /MEDIA/XP/AUDIO:switchMulti(I1;I2;;;I5)
- ◀ mO /MEDIA/XP/AUDIO:switchMulti=

8.7.6. Channel Mapping

The embedded/transmitted audio signal can be 2-channel LPCM or compressed (non-HBR) audio signal only. There are two possibilities in case of audio signal embedding/transmitting:

- If the selected signal is of type LPCM, the user can select the two channels to be transmitted.
- If the selected signal is compressed (non-HBR) audio, it can be embedded into the video stream without any further action.

Command and Response *#channelmapping #mapping*

- ▶ SET·/MEDIA/PORTS/AUDIO/<out>/PARAMETERS.MainOutputChannels=<left_channel>;<right_channel>
- ◀ pw·/MEDIA/PORTS/AUDIO/<out>/PARAMETERS.MainOutputChannels=<left_channel>;<right_channel>

Parameters

Identifier	Parameter description	Value	Value description
<left_channel>	Selected channels are transmitted to the left and right channels of the output port	1...8	Channel number
<right_channel>			

Example

- ▶ SET /MEDIA/PORTS/AUDIO/O26/PARAMETERS.MainOutputChannels=1;2
- ◀ pw /MEDIA/PORTS/AUDIO/O26/PARAMETERS.MainOutputChannels=1;2

8.7.7. Muting an Audio Input

Command and Response *#mute*

- ▶ CALL·/MEDIA/XP/AUDIO:muteSource(<in>)
- ◀ mO·/MEDIA/XP/AUDIO:muteSource=

Example

- ▶ CALL /MEDIA/XP/AUDIO:muteSource(I1)
- ◀ mO /MEDIA/XP/AUDIO:muteSource=

8.7.8. Unmuting an Audio Input

Command and Response *#unmute*

- ▶ CALL·/MEDIA/XP/AUDIO:unmuteSource(<in>)
- ◀ mO·/MEDIA/XP/AUDIO:unmuteSource=

Example

- ▶ CALL /MEDIA/XP/AUDIO:unmuteSource(I1;I3)
- ◀ mO /MEDIA/XP/AUDIO:unmuteSource=

8.7.9. Locking an Audio Input

Command and Response *#lock*

- ▶ CALL·/MEDIA/XP/AUDIO:lockSource(<in>)
- ◀ mO·/MEDIA/XP/AUDIO:lockSource=

Example

- ▶ CALL /MEDIA/XP/AUDIO:lockSource(I1;I2;I3)
- ◀ mO /MEDIA/XP/AUDIO:lockSource=

8.7.10. Unlocking an Audio Input

Command and Response *#unlock*

- ▶ CALL·/MEDIA/XP/AUDIO:unlockSource(<in>)
- ◀ mO·/MEDIA/XP/AUDIO:unlockSource=

Example

- ▶ CALL /MEDIA/XP/AUDIO:unlockSource(I1;I3)
- ◀ mO /MEDIA/XP/AUDIO:unlockSource=

8.7.11. Muting an Audio Output

Command and Response *#mute*

- ▶ CALL·/MEDIA/XP/AUDIO:muteDestination(<out>)
- ◀ mO·/MEDIA/XP/AUDIO:muteDestination=

Example

- ▶ CALL /MEDIA/XP/AUDIO:muteDestination(O1;O3)
- ◀ mO /MEDIA/XP/AUDIO:muteDestination=

8.7.12. Unmuting an Audio Output

Command and Response *#unmute*

- ▶ CALL·/MEDIA/XP/AUDIO:unmuteDestination(<out>)
- ◀ mO·/MEDIA/XP/AUDIO:unmuteDestination=

Example

- ▶ CALL /MEDIA/XP/AUDIO:unmuteDestination(O1;O2)
- ◀ mO /MEDIA/XP/AUDIO:unmuteDestination=

8.7.13. Locking an Audio Output

Command and Response *#lock*

- ▶ CALL·/MEDIA/XP/AUDIO:lockDestination(<out>)
- ◀ mO·/MEDIA/XP/AUDIO:lockDestination=

Example

- ▶ CALL /MEDIA/XP/AUDIO:lockDestination(O1;O4)
- ◀ mO /MEDIA/XP/AUDIO:lockDestination=

8.7.14. Unlocking an Audio Output

Command and Response *#unlock*

- ▶ CALL·/MEDIA/XP/AUDIO:unlockDestination(<out>)
- ◀ mO·/MEDIA/XP/AUDIO:unlockDestination=

Example

- ▶ CALL /MEDIA/XP/AUDIO:unlockDestination(O1;O2;O4)
- ◀ mO /MEDIA/XP/AUDIO:unlockDestination=

8.8. Video Source Port Settings - HDMI / OPTJ

The following settings are valid only for the following input boards: *#hdmi #optj*

- MX2M-4HDMI20-IB
- MX2M-4OPTJ-IB

8.8.1. Setting the HDCP

This setting allows sending non-encrypted content to a non-HDCP compliant display. See more information in the [HDCP Management](#) section.

Command and Response *#hdc*

- ▶ SET·/MEDIA/PORTS/VIDEO/<in>/PARAMETERS.HdcpVersion=<number>
- ◀ pw·/MEDIA/PORTS/VIDEO/<in>/PARAMETERS.HdcpVersion=<number>

Parameters

Identifier	Parameter description	Value	Value description
<number>	The setting sets the maximum enabled HDCP level	0	HDCP-encryption is disabled.
		1	Encryption level is HDCP 1.4
		2	Encryption level is HDCP 2.3

Example

- ▶ SET /MEDIA/PORTS/VIDEO/I1/PARAMETERS.HdcpVersion=2
- ◀ pw /MEDIA/PORTS/VIDEO/I1/PARAMETERS.HdcpVersion=2

8.8.2. Setting the Color Range

Command and Response *#colorrange*

- ▶ SET·/MEDIA/PORTS/VIDEO/<in>/PARAMETERS.InputColorRangeMode=<colorrange>
- ◀ pw·/MEDIA/PORTS/VIDEO/<in>/PARAMETERS.InputColorRangeMode=<colorrange>

Parameters

Identifier	Parameter description	Value	Value description
<colorrange>	Color range setting	Auto	Color range depends on the input signal.
		Full	Input is treated as full color range.
		Limited	Input is treated as limited color range.

Example

- ▶ SET /MEDIA/PORTS/VIDEO/I1/PARAMETERS.InputColorRangeMode=Full
- ◀ pw /MEDIA/PORTS/VIDEO/I1/PARAMETERS.InputColorRangeMode=Full

8.8.3. Setting the Hot Plug Detect (HPD)

Command and Response *#hotplugdetect*

- ▶ SET·/MEDIA/PORTS/VIDEO/<in>/PARAMETERS.EnableHPD=<hpd_setting>
- ◀ pw·/MEDIA/PORTS/VIDEO/<in>/PARAMETERS.EnableHPD=<hpd_setting>

Parameters

Identifier	Parameter description	Value	Value description
<hpd_setting>	Hot plug detect setting	AUTO	Hot plug detect state matches input 5V state.
		ON	Hot plug detect is enabled.
		OFF	Hot plug detect is disabled.

Example

- ▶ SET /MEDIA/PORTS/VIDEO/I1/PARAMETERS.EnableHPD=ON
- ◀ pw /MEDIA/PORTS/VIDEO/I1/PARAMETERS.EnableHPD=ON

8.9. Video Source Port Settings - DP

The following settings are valid only for the following input boards: *#displayport #dp*

- MX2M-DH-4DP12-IB

8.9.1. Setting the Maximum Lane Number

Command and Response

- ▶ SET·/MEDIA/PORTS/VIDEO/<in>/PARAMETERS.DpMaxLaneCount=<lane>
- ◀ pw·/MEDIA/PORTS/VIDEO/<in>/PARAMETERS.DpMaxLaneCount=<lane>

Parameters

Identifier	Parameter description	Value	Value description
<lane>	DisplayPort data transmission proceeds through the lanes. This defines the maximum number of lanes used.	1	One lane is able to transmit 5.4 Gbps of data.
		2	Two lanes are able to transmit 10.8 Gbps of data.
		4	Four lanes are able to transmit 21.6 Gbps of data.

Example

- ▶ SET /MEDIA/PORTS/VIDEO/I1/PARAMETERS.DpMaxLaneCount=4
- ◀ pw /MEDIA/PORTS/VIDEO/I1/PARAMETERS.DpMaxLaneCount=4

8.9.2. Setting the Maximum Link Data Rate

Command and Response

- ▶ SET /MEDIA/PORTS/VIDEO/<in>/PARAMETERS.DpMaxLinkRate=<data_rate>
- ◀ pw /MEDIA/PORTS/VIDEO/<in>/PARAMETERS.DpMaxLinkRate=<data_rate>

Parameters

Identifier	Parameter description	Value	Value description
<data_rate>	The maximum data rate per lane.	RBR	Reduced Bit Rate uses 1.62 Gbps bandwidth.
		HBR	High Bit Rate uses 2.70 Gbps bandwidth.
		HBR2	High Bit Rate2 uses 5.40 Gbps bandwidth.

Example

- ▶ SET /MEDIA/PORTS/VIDEO/I1/PARAMETERS.DpMaxLinkRate=HBR2
- ◀ pw /MEDIA/PORTS/VIDEO/I1/PARAMETERS.DpMaxLinkRate=HBR2

8.9.3. Setting the DP Power

This property allows providing 1.5W (500mA @ 3.3W) power on the DP_PWR pin. The default value is true.

Command and Response #dppower

- ▶ SET /MEDIA/PORTS/VIDEO/<in>/PARAMETERS.DpEnablePower=<logical_value>
- ◀ pw /MEDIA/PORTS/VIDEO/<in>/PARAMETERS.DpEnablePower=<logical_value>

Parameters

Identifier	Parameter description	Value	Value description
<logical_value>	DP power sending setting	true	The board sends 1.5W power on the chosen port.
		false	The board does not provide any power on the chosen port.

Example

- ▶ SET /MEDIA/PORTS/VIDEO/I1/PARAMETERS.DpEnablePower=true
- ◀ pw /MEDIA/PORTS/VIDEO/I1/PARAMETERS.DpEnablePower=true

8.9.4. Setting the Test Pattern Mode

Command and Response #testpattern #nosyncscreen

- ▶ SET /MEDIA/PORTS/VIDEO/<in>/PARAMETERS.DpTpgMode=<tpg_mode>
- ◀ pw /MEDIA/PORTS/VIDEO/<in>/PARAMETERS.DpTpgMode=<tpg_mode>

Parameters

Identifier	Parameter description	Value	Value description
<tpg_mode>	The testpattern is enabled or disabled.	0	Disabled
		1	Enabled

Example

- ▶ SET /MEDIA/PORTS/VIDEO/I1/PARAMETERS.DpTpgMode=1
- ◀ pw /MEDIA/PORTS/VIDEO/I1/PARAMETERS.DpTpgMode=1

8.9.5. Setting the Color Space Conversion

INFO: DisplayPort signals over 18Gbps will be converted down by either truncating bit depth or by converting RGB signal to YUV 4:2:2 12-bit signal based on user selection. The second option will not reduce the color depth, instead it results in loss of chroma information.

Command and Response #colorspace

- ▶ SET /MEDIA/PORTS/VIDEO/<in>/PARAMETERS.DpConversion=<conversion_mode>
- ◀ pw /MEDIA/PORTS/VIDEO/<in>/PARAMETERS.DpConversion=<conversion_mode>

Parameters

Identifier	Parameter description	Value	Value description
<conversion_mode>	Color space conversion mode	OFF	Pass-through mode, the video signal is transmitted without any changing.
		422	The video converter subsamples the signal to 4:2:2.
		420	The video converter subsamples the signal to 4:2:0.

Example

- ▶ SET /MEDIA/PORTS/VIDEO/I1/PARAMETERS.DpConversion=422
- ◀ pw /MEDIA/PORTS/VIDEO/I1/PARAMETERS.DpConversion=422

8.9.6. Setting the Color Range

Command and Response *#colorrange*

- ▶ SET·/MEDIA/PORTS/VIDEO/<in>/PARAMETERS.InputColorRangeMode=<colorrange>
- ◀ pw·/MEDIA/PORTS/VIDEO/<in>/PARAMETERS.InputColorRangeMode=<colorrange>

Parameters

Identifier	Parameter description	Value	Value description
<colorrange>	Color range setting	Auto	Color range depends on the input signal.
		Full	Input is treated as full color range.
		Limited	Input is treated as limited color range.

Example

- ▶ SET /MEDIA/PORTS/VIDEO/I1/PARAMETERS.InputColorRangeMode=Full
- ◀ pw /MEDIA/PORTS/VIDEO/I1/PARAMETERS.InputColorRangeMode=Full

8.9.7. Restarting Link Training

This method is equal to pulling out the DP connector and plugging it back in.

Command and Response *#linktraining*

- ▶ CALL·/MEDIA/PORTS/VIDEO/<in>/PARAMETERS:DpLinkTrain()
- ◀ mO·/MEDIA/PORTS/VIDEO/<in>/PARAMETERS:DpLinkTrain=

Example

- ▶ CALL /MEDIA/PORTS/VIDEO/I1/PARAMETERS:DpLinkTrain()
- ◀ mO /MEDIA/PORTS/VIDEO/I1/PARAMETERS:DpLinkTrain=

8.9.8. Setting the Hot Plug Detect (HPD)

Command and Response *#hotplugdetect #hpd*

- ▶ SET·/MEDIA/PORTS/VIDEO/<in>/PARAMETERS.EnableHPD=<hpd_setting>
- ◀ pw·/MEDIA/PORTS/VIDEO/<in>/PARAMETERS.EnableHPD=<hpd_setting>

Parameters

Identifier	Parameter description	Value	Value description
<hpd_setting>	Hot plug detect setting	AUTO	Hot plug detect state matches input 5V state.
		ON	Hot plug detect is enabled.
		OFF	Hot plug detect is disabled.

Example

- ▶ SET /MEDIA/PORTS/VIDEO/I1/PARAMETERS.EnableHPD=ON
- ◀ pw /MEDIA/PORTS/VIDEO/I1/PARAMETERS.EnableHPD=ON

8.9.9. Setting the HDCP

This setting allows sending non-encrypted content to a non-HDCP compliant display. See more information in the [HDCP Management](#) section.

Command and Response *#hdcpc*

- ▶ SET·/MEDIA/PORTS/VIDEO/<in>/PARAMETERS.HdcpVersion=<number>
- ◀ pw·/MEDIA/PORTS/VIDEO/<in>/PARAMETERS.HdcpVersion=<number>

Parameters

Identifier	Parameter description	Value	Value description
<number>	The setting sets the maximum enabled HDCP level	0	HDCP-encryption is disabled.
		1	Encryption level is HDCP 1.4
		2	Encryption level is HDCP 2.3

Example

- ▶ SET /MEDIA/PORTS/VIDEO/I1/PARAMETERS.HdcpVersion=2
- ◀ pw /MEDIA/PORTS/VIDEO/I1/PARAMETERS.HdcpVersion=2

8.10. Video Source Port Settings - TPX

The following settings are valid only for the following input boards: *#tpx*

- MX2M-4TPX-IB

8.10.1. Setting the HDCP

This setting allows sending non-encrypted content to a non-HDCP compliant display. See more information in the [HDCP Management](#) section.

Command and Response *#hdc*

- ▶ SET·/MEDIA/PORTS/VIDEO/<in>/PARAMETERS.HdcpVersion=<number>
- ◀ pw·/MEDIA/PORTS/VIDEO/<in>/PARAMETERS.HdcpVersion=<number>

Parameters

Identifier	Parameter description	Value	Value description
<number>	The setting sets the maximum enabled HDCP level	0	HDCP-encryption is disabled.
		1	Encryption level is HDCP 1.4
		2	Encryption level is HDCP 2.3

Example

- ▶ SET /MEDIA/PORTS/VIDEO/I1/PARAMETERS.HdcpVersion=2
- ◀ pw /MEDIA/PORTS/VIDEO/I1/PARAMETERS.HdcpVersion=2

8.10.2. Setting the Hot Plug Detect (HPD)

Command and Response *#hotplugdetect #hpd*

- ▶ SET·/MEDIA/PORTS/VIDEO/<in>/PARAMETERS.EnableHPD=<hpd_setting>
- ◀ pw·/MEDIA/PORTS/VIDEO/<in>/PARAMETERS.EnableHPD=<hpd_setting>

Parameters

Identifier	Parameter description	Value	Value description
<hpd_setting>	Hot plug detect setting	AUTO	Hot plug detect state matches input 5V state.
		ON	Hot plug detect is enabled.
		OFF	Hot plug detect is disabled.

Example

- ▶ SET /MEDIA/PORTS/VIDEO/I1/PARAMETERS.EnableHPD=ON
- ◀ pw /MEDIA/PORTS/VIDEO/I1/PARAMETERS.EnableHPD=ON

8.10.3. PoE (Power over Ethernet) Setting

Command and Response *#poe*

- ▶ SET·/MEDIA/PORTS/VIDEO/<in>/PARAMETERS.POE.Enabled=<logical_value>
- ◀ pw·/MEDIA/PORTS/VIDEO/<in>/PARAMETERS.POE.Enabled=<logical_value>

Parameters

Identifier	Parameter description	Value	Value description
<logical_value>	PoE setting	true	PoE is enabled and the port will send power to the connected extender.
		false	PoE is disabled.

Example

- ▶ SET /MEDIA/PORTS/VIDEO/I1/PARAMETERS.POE.Enabled=true
- ◀ pw /MEDIA/PORTS/VIDEO/I1/PARAMETERS.POE.Enabled=true

8.11. Video Destination Port Settings - HDMI / OPTJ / TPX

The following settings are valid only for the following output boards: *#hdmi #optj #tpx*

- MX2M-4HDMI20-OB
- MX2M-4OPTJ-OB
- MX2M-4TPX-OB

8.11.1. Setting the Color Space Conversion

ATTENTION: The MX2M-4HDMI20-OB and MX2M-4HDMI20-OB-E output boards accept video signals in 8, 10 and 12 bit color depth, but the sampling pattern conversion is always made in 8 bit.

Command and Response *#colorspace*

- ▶ SET·/MEDIA/PORTS/VIDEO/<out>/PARAMETERS.ColorSpaceSetting=<conversion_mode>
- ◀ pw·/MEDIA/PORTS/VIDEO/<out>/PARAMETERS.ColorSpaceSetting=<conversion_mode>

Parameters

Identifier	Parameter description	Value	Value description
<conversion_mode>	Color space conversion mode	Passthrough	Passthrough mode, the color space setting depends on the source signal.
		YCbCr 4:2:2	YCbCr 4:4:4 to YCbCr 4:2:2 conversion

Example

- ▶ SET /MEDIA/PORTS/VIDEO/O1/PARAMETERS.ColorSpaceSetting=Passthrough
- ◀ pw /MEDIA/PORTS/VIDEO/O1/PARAMETERS.ColorSpaceSetting=Passthrough

8.11.2. Setting the Signal Type

Command and Response

- ▶ SET·/MEDIA/PORTS/VIDEO/<out>/PARAMETERS.ForcedSignalType=<signal_type>
- ◀ pw·/MEDIA/PORTS/VIDEO/<out>/PARAMETERS.ForcedSignalType=<signal_type>

Parameters

Identifier	Parameter description	Value	Value description
<signal_type>	Forced signal type of the output stream	AUTO	Signal type depends on the input signal.
		HDMI	Forced HDMI
		DVI	Forced DVI

Example

- ▶ SET /MEDIA/PORTS/VIDEO/O1/PARAMETERS.ForcedSignalType=HDMI
- ◀ pw /MEDIA/PORTS/VIDEO/O1/PARAMETERS.ForcedSignalType=HDMI

8.11.3. Setting the Power 5V

DIFFERENCE: The setting is only available for the MX2M-4HDMI20-OB and MX2M-4TPX-OB boards.

The setting enables/disables power 5V output.

Command and Response #power5v

- ▶ SET·/MEDIA/PORTS/VIDEO/<out>/PARAMETERS.Enable5V=<power_mode>
- ◀ pw·/MEDIA/PORTS/VIDEO/<out>/PARAMETERS.Enable5V=<power_mode>

Parameters

Identifier	Parameter description	Value	Value description
<power_mode>	Power 5V output mode	AUTO	On change of TMDS clock, power 5V is disabled for 1s, after that it is enabled again.
		ON	Enabled
		OFF	Disabled

Example

- ▶ SET /MEDIA/PORTS/VIDEO/O1/PARAMETERS.Enable5V=ON
- ◀ pw /MEDIA/PORTS/VIDEO/O1/PARAMETERS.Enable5V=ON

8.11.4. Setting the HDCP Mode

Command and Response #hdcpc

- ▶ SET·/MEDIA/PORTS/VIDEO/<out>/PARAMETERS.HdcpMode=<HDCP_mode>
- ◀ pw·/MEDIA/PORTS/VIDEO/<out>/PARAMETERS.HdcpMode=<HDCP_mode>

Parameters

Identifier	Parameter description	Value	Value description
<HDCP_mode>	HDCP mode setting	AUTO	The setting is the same as on the input port. The encryption of the signal on the output is the same as on the input.
		ALWAYS	Enabling maximum possible encryption all the time. The setting applies encryption on originally unencrypted streams.

Example

- ▶ SET /MEDIA/PORTS/VIDEO/O1/PARAMETERS.HdcpMode=AUTO
- ◀ pw /MEDIA/PORTS/VIDEO/O1/PARAMETERS.HdcpMode=AUTO

8.11.5. Setting the Audio Source

The setting sets the source of the embedded audio stream.

Command and Response #embedder #audio

- ▶ SET·/MEDIA/PORTS/VIDEO/<out>/PARAMETERS.AudioSource=<audio_source>
- ◀ pw·/MEDIA/PORTS/VIDEO/<out>/PARAMETERS.AudioSource=<audio_source>

Parameters

Identifier	Parameter description	Value	Value description
<audio_source>	Source of the audio stream setting	Hdmi	The original embedded audio signal is transmitted in the output stream.
		AudioLayer	The audio stream is selected and embedded from the audio layer (e.g. analog audio signal).
		Off	Audio signal is disabled in the video stream.

Example

- ▶ SET /MEDIA/PORTS/VIDEO/O1/PARAMETERS.AudioSource=AudioLayer
- ◀ pw /MEDIA/PORTS/VIDEO/O1/PARAMETERS.AudioSource=AudioLayer

8.11.6. PoE (Power over Ethernet) Setting

DIFFERENCE: The setting is only available for the MX2M-4TPX-OB board.

Command and Response *#poe*

- ▶ SET·/MEDIA/PORTS/VIDEO/<out>/PARAMETERS/POE.Enabled=<logical_value>
- ◀ pw·/MEDIA/PORTS/VIDEO/<out>/PARAMETERS/POE.Enabled=<logical_value>

Parameters

Identifier	Parameter description	Value	Value description
<logical_value>	PoE setting	true	PoE is enabled and the port will send power to the connected extender.
		false	PoE is disabled.

Example

- ▶ SET /MEDIA/PORTS/VIDEO/O1/PARAMETERS/POE.Enabled=true
- ◀ pw /MEDIA/PORTS/VIDEO/O1/PARAMETERS/POE.Enabled=true

8.12. Analog Audio Port Properties

INFO: The analog audio ports of the MX2M-AUX-8AUDIO board can be configured as an input or output by the user. See the details about it in the [Analog Audio Port Configuration](#) section.

INFO: Audio input port numbering can be found in the [Audio Input Port Numbering](#), the audio output port numbering can be found in the [Audio Output Port Numbering](#) section.

The following settings are valid only for the following auxiliary (LS) board: *#analogaudio #audio*

- MX2M-AUX-8AUDIO

8.12.1. Querying the Input Ports of the Board

The query returns which ports are configured as inputs out of the eight available ones.

Command and Response

- ▶ GET·/SYS/<board>.AudioInput
- ◀ pw·/SYS/<board>.AudioInput=<status_of_the_ports>

Parameters

Identifier	Parameter description	Value	Value description
<board>	The identifier of the board.	LS1...LS4	Auxiliary (LS - Low Speed) board ID, the values can be LS1, LS2, LS3, or LS4.
<status_of_the_ports>	The list of recent status of the analog audio ports	0	The port is not input port.
		1	The port is configured as input.

Example

- ▶ GET /SYS/LS1.AudioInput
- ◀ pw /SYS/LS1.AudioInput=1;1;1;0;0;0;0;0;0;0;0;0;0;0;0;0;0

Explanation

The first four ports are configured as inputs.

8.12.2. Querying the Output Ports of the Board

The query returns which ports are configured as outputs out of the eight available ones.

Command and Response

- ▶ GET /SYS/<board>.AudioOutput
- ◀ pw /SYS/<board>.AudioOutput=<status_of_the_ports>

Parameters

Identifier	Parameter description	Value	Value description
<board>	The identifier of the board.	LS1...LS4	Auxiliary (LS - Low Speed) board ID, the values can be LS1, LS2, LS3, or LS4.
<status_of_the_ports>	The list of recent status of the analog audio ports	0	The port is not output port.
		1	The port is configured as output.

Example

- ▶ GET /SYS/LS1.AudioOutput
- ◀ pw /SYS/LS1.AudioOutput=0;0;0;0;1;1;1;0;0;0;0;0;0

Explanation

The last four ports are configured as outputs.

8.12.3. Setting the Volume in dB

Command and Response #volume

- ▶ SET /MEDIA/PORTS/AUDIO/<in|out>/PARAMETERS.VolunedB=<volume>
- ◀ pw /MEDIA/PORTS/AUDIO/<in|out>/PARAMETERS.VolunedB=<volume>

Parameters

Parameter	Parameter description
<volume>	Sets the input volume (attenuation) between -95.625 dB and 0 dB in step of -0.375dB.

Example

- ▶ SET /MEDIA/PORTS/AUDIO/I41/PARAMETERS.VolunedB=-15
- ◀ pw /MEDIA/PORTS/AUDIO/I41/PARAMETERS.VolunedB=-15.000

8.12.4. Setting the Volume in dB by Steps

Command and Response

- ▶ CALL /MEDIA/PORTS/AUDIO/<in|out>/PARAMETERS:stepVolunedB(<volume>)
- ◀ m0 /MEDIA/PORTS/AUDIO/<in|out>/PARAMETERS:stepVolunedB=

Example

- ▶ CALL /MEDIA/PORTS/AUDIO/I41/PARAMETERS:stepVolunedB(4)
- ◀ pw /MEDIA/PORTS/AUDIO/I41/PARAMETERS:stepVolunedB=

8.12.5. Setting the Volume in Percent

Command and Response

- ▶ SET /MEDIA/PORTS/AUDIO/<in|out>/PARAMETERS.VolumePercent=<percent>
- ◀ pw /MEDIA/PORTS/AUDIO/<in|out>/PARAMETERS.VolumePercent=<percent>

Example

- ▶ SET /MEDIA/PORTS/AUDIO/I41/PARAMETERS.VolumePercent=50
- ◀ pw /MEDIA/PORTS/AUDIO/I41/PARAMETERS.VolumePercent=50

8.12.6. Setting the Volume in Percent by Steps

Command and Response

- ▶ CALL /MEDIA/PORTS/AUDIO/<in|out>/PARAMETERS:stepVolumePercent(<percent>)
- ◀ m0 /MEDIA/PORTS/AUDIO/<in|out>/PARAMETERS:stepVolumePercent=

Example

- ▶ CALL /MEDIA/PORTS/AUDIO/I41/PARAMETERS:stepVolumePercent(20)
- ◀ pw /MEDIA/PORTS/AUDIO/I41/PARAMETERS:stepVolumePercent=

8.12.7. Setting the Balance

Command and Response *#balance*

- ▶ SET /MEDIA/PORTS/AUDIO/<in|out>/PARAMETERS.Balance=<balance>
- ◀ pw /MEDIA/PORTS/AUDIO/<in|out>/PARAMETERS.Balance=<balance>

Parameters

Parameter	Parameter description
<balance>	Sets the balance; -100 means left balance, +100 means right balance, step is 1. Center is 0 (default).

Example

- ▶ SET /MEDIA/PORTS/AUDIO/O41/PARAMETERS.Balance=-15
- ◀ pw /MEDIA/PORTS/AUDIO/O41/PARAMETERS.Balance=-15.000

8.12.8. Setting the Balance by Steps

Command and Response

- ▶ CALL /MEDIA/PORTS/AUDIO/<in|out>/PARAMETERS:stepBalance(<balance>)
- ◀ mO /MEDIA/PORTS/AUDIO/<in|out>/PARAMETERS:stepBalance=

Example

- ▶ CALL /MEDIA/PORTS/AUDIO/I41/PARAMETERS:stepBalance(34)
- ◀ pw /MEDIA/PORTS/AUDIO/I41/PARAMETERS:stepBalance=

8.12.9. Setting the Gain

Command and Response *#gain*

- ▶ SET /MEDIA/PORTS/AUDIO/<in>/PARAMETERS.Gain=<gain>
- ◀ pw /MEDIA/PORTS/AUDIO/<in>/PARAMETERS.Gain=<gain>

Parameters

Parameter	Parameter description
<gain>	Sets the input gain between -12 dB and -6 dB.

Example

- ▶ SET /MEDIA/PORTS/AUDIO/I41/PARAMETERS.Gain=-10
- ◀ pw /MEDIA/PORTS/AUDIO/I41/PARAMETERS.Gain=-10.000

8.13. Dante® Audio Settings

INFO: Audio input port numbering can be found in the [Audio Input Port Numbering](#), the audio output port numbering can be found in the [Audio Output Port Numbering](#) section.

The following settings are valid only for the following auxiliary (LS) board: *#dante #aes67*

- MX2M-AUX-DANTE-32CH

8.13.1. Renaming the Channel Label

Command and Response

- ▶ SET /MEDIA/PORTS/AUDIO/<in|out>/PARAMETERS.ChannelLabel<number>=<channellabel>
- ◀ pw /MEDIA/PORTS/AUDIO/<in|out>/PARAMETERS.ChannelLabel<number>=<channellabel>

Parameters

Identifier	Parameter description	Value	Value description
<number>	Number of the channel	0	ChannelLabel1
		1	ChannelLabel2
<channellabel>	Unique name of the channel		Unique name of the channel. The following characters are not allowed in the parameter: () { } # % \ \r \n \t

Example

- ▶ SET /MEDIA/PORTS/AUDIO/I25/PARAMETERS.ChannelLabel1=FlacPlayer_Left
- ◀ pw /MEDIA/PORTS/AUDIO/I25/PARAMETERS.ChannelLabel1=FlacPlayer_Left

8.13.2. Querying the Sample Rate

Command and Response

- ▶ GET /MEDIA/PORTS/AUDIO/<in|out>/PARAMETERS.SampleRate
- ◀ pr /MEDIA/PORTS/AUDIO/<in|out>/PARAMETERS.SampleRate=<sampleRate>

Example

- ▶ GET /MEDIA/PORTS/AUDIO/I25/PARAMETERS.SampleRate
- ◀ pr /MEDIA/PORTS/AUDIO/I25/PARAMETERS.SampleRate=48000

8.14. System Monitoring Commands

TIPS AND TRICKS: All listed parameters which are listed in this section can be queried in one step with the following command:

▶ GETALL /MEDIA/PORTS/VIDEO/<in|out>/PARAMETERS

8.14.1. Querying Connected Device Presence

Connected property indicates whether a cable or a device is connected to the input or output port.

Command and Response

- ▶ GET /MEDIA/PORTS/VIDEO/<in|out>/PARAMETERS.Connected
- ◀ pr /MEDIA/PORTS/VIDEO/<in|out>/PARAMETERS.Connected=<parameter>

Parameters

Parameter	Parameter description	Value	Value description
<parameter>	Connected device or cable indicator	0	Not present
		1	Present
		F	Unknown

Example

- ▶ GET /MEDIA/PORTS/VIDEO/I1/PARAMETERS.Connected
- ◀ pr /MEDIA/PORTS/VIDEO/I1/PARAMETERS.Connected=1

8.14.2. Querying Video Signal Presence on a Port

SignalPresent property indicates valid signal present on the port.

Command and Response

- ▶ GET /MEDIA/PORTS/VIDEO/<in|out>/PARAMETERS.SignalPresent
- ◀ pr /MEDIA/PORTS/VIDEO/<in|out>/PARAMETERS.SignalPresent=<parameter>

Parameters

Parameter	Parameter description	Value	Value description
<parameter>	Signal present indicator	0	Not present
		1	Present
		F	Unknown

Example

- ▶ GET /MEDIA/PORTS/VIDEO/O1/PARAMETERS.SignalPresent
- ◀ pr /MEDIA/PORTS/VIDEO/O1/PARAMETERS.SignalPresent=1

#status #systemmonitor

8.14.3. Querying the Signal Type

SignalType property provides the type of the video signal.

Command and Response

- ▶ GET /MEDIA/PORTS/VIDEO/<in|out>/PARAMETERS.SignalType
- ◀ pr /MEDIA/PORTS/VIDEO/<in|out>/PARAMETERS.SignalType=<signal_type>

Parameters

Parameter	Parameter description	Value	Value description
<signal_type>	Signal type	0	DVI
		1	HDMI
		2	DP
		F	Unknown

Example

- ▶ GET /MEDIA/PORTS/VIDEO/I1/PARAMETERS.SignalType
- ◀ pr /MEDIA/PORTS/VIDEO/I1/PARAMETERS.SignalType=2

8.14.4. Querying the Resolution of the Stream

The query returns with the resolution of the stream without blanking.

Command and Response

- ▶ GET /MEDIA/PORTS/VIDEO/<in|out>/PARAMETERS.Resolution
- ◀ pr /MEDIA/PORTS/VIDEO/<in|out>/PARAMETERS.Resolution=<resolution>

Example

- ▶ GET /MEDIA/PORTS/VIDEO/O1/PARAMETERS.Resolution
- ◀ pr /MEDIA/PORTS/VIDEO/O1/PARAMETERS.Resolution=3840x2160p60

8.14.5. Querying the Total Size of the Stream

The query returns with the resolution of the stream including the blanking.

Command and Response

- ▶ GET /MEDIA/PORTS/VIDEO/<in|out>/PARAMETERS.TotalSize
- ◀ pr /MEDIA/PORTS/VIDEO/<in|out>/PARAMETERS.TotalSize=<resolution>

Example

- ▶ GET /MEDIA/PORTS/VIDEO/I1/PARAMETERS.TotalSize
- ◀ pr /MEDIA/PORTS/VIDEO/I1/PARAMETERS.TotalSize=4400x2248

8.14.6. Querying Embedded Audio Presence

EmbeddedAudioPresent property indicates that embedded audio is present in the video stream.

Command and Response

- ▶ GET /MEDIA/PORTS/VIDEO/<in|out>/PARAMETERS.EmbeddedAudioPresent
- ◀ pr /MEDIA/PORTS/VIDEO/<in|out>/PARAMETERS.EmbeddedAudioPresent=<parameter>

Parameters

Parameter	Parameter description	Value	Value description
<parameter>	Embedded audio presence indicator	0	Not present
		1	Present
		F	Unknown

Example

- ▶ GET /MEDIA/PORTS/VIDEO/01/PARAMETERS.EmbeddedAudioPresent
- ◀ pr /MEDIA/PORTS/VIDEO/01/PARAMETERS.EmbeddedAudioPresent=1

8.14.7. Querying the Color Space of the Stream

Command and Response

- ▶ GET /MEDIA/PORTS/VIDEO/<in|out>/PARAMETERS.ColorSpace
- ◀ pr /MEDIA/PORTS/VIDEO/<in|out>/PARAMETERS.ColorSpace=<parameter>

Parameters

Parameter	Parameter description	Value	Value description
<parameter>	Color space of the stream	1	RGB
		2	YUV 4:4:4
		3	YUV 4:2:2
		4	YUV 4:2:0
		F	Unknown

Example

- ▶ GET /MEDIA/PORTS/VIDEO/I1/PARAMETERS.ColorSpace
- ◀ pr /MEDIA/PORTS/VIDEO/I1/PARAMETERS.ColorSpace=4

8.14.8. Querying the Color Range of the Stream

Command and Response

- ▶ GET /MEDIA/PORTS/VIDEO/<in|out>/PARAMETERS.ColorRange
- ◀ pr /MEDIA/PORTS/VIDEO/<in|out>/PARAMETERS.ColorRange=<parameter>

Parameters

Parameter	Parameter description	Value	Value description
<parameter>	Color range of the stream	0	Full
		1	Limited
		F	Unknown

Example

- ▶ GET /MEDIA/PORTS/VIDEO/01/PARAMETERS.ColorRange
- ◀ pr /MEDIA/PORTS/VIDEO/01/PARAMETERS.ColorRange=0

8.14.9. Querying the Color Depth of the Stream

Command and Response

- ▶ GET /MEDIA/PORTS/VIDEO/<in|out>/PARAMETERS.ColorDepth
- ◀ pr /MEDIA/PORTS/VIDEO/<in|out>/PARAMETERS.ColorDepth=<parameter>

Parameters

Parameter	Parameter description	Value	Value description
<parameter>	Color depth of the stream	0	8 bit per pixel
		1	10 bit per pixel
		2	12 bit per pixel
		3	16 bit per pixel
		F	Unknown

Example

- ▶ GET /MEDIA/PORTS/VIDEO/I1/PARAMETERS.ColorDepth
- ◀ pr /MEDIA/PORTS/VIDEO/I1/PARAMETERS.ColorDepth=1

8.14.10. Querying the HDCP-encryption Presence

Command and Response

- ▶ GET /MEDIA/PORTS/VIDEO/<in|out>/PARAMETERS.HdcpActive
- ◀ pr /MEDIA/PORTS/VIDEO/<in|out>/PARAMETERS.HdcpActive=<parameter>

Parameters

Parameter	Parameter description	Value	Value description
<parameter>	Presence of the HDCP-encryption	0	Not encrypted
		1	Encrypted
		F	Unknown

Example

- ▶ GET /MEDIA/PORTS/VIDEO/01/PARAMETERS.HdcpActive
- ◀ pr /MEDIA/PORTS/VIDEO/01/PARAMETERS.HdcpActive=0

8.14.11. Querying the HDCP-encryption Level of the Stream

Command and Response

- ▶ GET /MEDIA/PORTS/VIDEO/<in|out>/PARAMETERS.ActiveHdcpVersion
- ◀ pr /MEDIA/PORTS/VIDEO/<in|out>/PARAMETERS.ActiveHdcpVersion=<parameter>

Parameters

Parameter	Parameter description	Value	Value description
<parameter>	HDCP-encryption level of the stream	0	Not encrypted
		1	HDCP 1.4
		2	HDCP 2.3

Example

- ▶ GET /MEDIA/PORTS/VIDEO/01/PARAMETERS.ActiveHdcpVersion
- ◀ pr /MEDIA/PORTS/VIDEO/01/PARAMETERS.ActiveHdcpVersion=0

8.14.12. Querying the Maximum Supported HDCP-encryption Level

Command and Response

- ▶ GET /MEDIA/PORTS/VIDEO/<in|out>/PARAMETERS.MaxSupportedHdcpVersion
- ◀ pr /MEDIA/PORTS/VIDEO/<in|out>/PARAMETERS.MaxSupportedHdcpVersion=<parameter>

Parameters

Parameter	Parameter description	Value	Value description
<parameter>	HDCP-encryption level of the stream	0	None
		1	HDCP 1.4
		2	HDCP 2.3

Example

- ▶ GET /MEDIA/PORTS/VIDEO/I1/PARAMETERS.MaxSupportedHdcpVersion
- ◀ pr /MEDIA/PORTS/VIDEO/I1/PARAMETERS.MaxSupportedHdcpVersion=2

8.14.13. Querying the HDCP Error

Command and Response

- ▶ GET /MEDIA/PORTS/VIDEO/<in|out>/PARAMETERS.HdcpError
- ◀ pr /MEDIA/PORTS/VIDEO/<in|out>/PARAMETERS.HdcpError=<parameter>

Parameters

Parameter	Parameter description	Value	Value description
<parameter>	HDCP error presence indicator	0	None
		1	Link integrity
		2	Incompatible

Example

- ▶ GET /MEDIA/PORTS/VIDEO/01/PARAMETERS.HdcpError
- ◀ pr /MEDIA/PORTS/VIDEO/01/PARAMETERS.HdcpError=0

8.14.14. Querying the TMDs Error Counters

Command and Response

- ▶ GET /MEDIA/PORTS/VIDEO/<in|out>/PARAMETERS.TmdsErrorCounters
- ◀ pr /MEDIA/PORTS/VIDEO/<in|out>/PARAMETERS.TmdsErrorCounters=<ch0_error_cnt>;<ch1_error_cnt>;<ch2_error_cnt>

Parameters

Parameter	Description
<ch0_error_cnt>	TMDS error counter of the channel 0.
<ch1_error_cnt>	TMDS error counter of the channel 1.
<ch2_error_cnt>	TMDS error counter of the channel 2.

Example

- ▶ GET /MEDIA/PORTS/VIDEO/I1/PARAMETERS.TmdsErrorCounters
- ◀ pr /MEDIA/PORTS/VIDEO/I1/PARAMETERS.TmdsErrorCounters=0;0;0

8.14.15. Querying the Audio Mismatch Status

The query returns the audio mismatch status of the audio output port.

Command and Response

- ▶ GET /MEDIA/PORTS/AUDIO/<out>/PARAMETERS.AudioMismatch
- ◀ pr /MEDIA/PORTS/AUDIO/<out>/PARAMETERS.AudioMismatch=<status>

Parameters

Parameter	Parameter description	Value	Value description
<status>	Audio mismatch status	No mismatch	No mismatch
		Compressed audio	Compressed audio
		Channel not found thus falling back	Channel not found, thus falling back
		Channel not found and cannot fall back	Channel not found and cannot fall back
		HBR audio	HBR audio

Example

- ▶ GET /MEDIA/PORTS/VIDEO/O1/PARAMETERS.AudioMismatch
- ◀ pr /MEDIA/PORTS/VIDEO/O1/PARAMETERS.AudioMismatch=No mismatch

8.15. Preset Handling

The matrix switcher can store presets and the following are stored in each slot: input/output crosspoint state, muted/unmuted states. Preset loading has an effect on all ports, except the locked ones.

8.15.1. Creating a New Preset

Command and Response #preset

- ▶ CALL /MEDIA/PRESET:create(<preset_name>,VIDEO)
- ◀ mO /MEDIA/PRESET:create=

Parameters

Up to 16 characters are allowed as <preset_name>. Letters (A-Z and a-z), hyphen (-), underscore (_), and numbers (0-9) are accepted. 'VIDEO' is a mandatory parameter.

Example

- ▶ CALL /MEDIA/PRESET:create(My_pres,VIDEO)
- ◀ mO /MEDIA/PRESET:create=

Explanation

The preset is stored as a new node (My_pres) under the /MEDIA/PRESET/ node.

8.15.2. Saving the Settings to an Existing Preset

Command and Response

- ▶ CALL /MEDIA/PRESET/<preset_name>:save(1)
- ◀ mO /MEDIA/PRESET/<preset_name>:save=

Example

- ▶ CALL /MEDIA/PRESET/My_pres:save(My_pres)
- ◀ mO /MEDIA/PRESET/My_pres:save=

The existing 'My_pres' has been overwritten with the current settings.

8.15.3. Loading a Preset

Command and Response

- ▶ CALL /MEDIA/PRESET/<preset_name>:load()
- ◀ mO /MEDIA/PRESET/<preset_name>:load=

Example

- ▶ CALL /MEDIA/PRESET/My_pres:load()
- ◀ mO /MEDIA/PRESET/My_pres:load=

Explanation

'My_pres' preset has been loaded and applied.

8.16.5. Copying an EDID to User Memory

Command and Response

- ▶ CALL /EDID:copy(<dynamic|emulated|factory|user>:<user>)
- ◀ mO /EDID:copy

Example

- ▶ CALL /EDID:copy(D1:U1;F148:U2)
- ◀ mO /EDID:copy

The EDID of the last connected sink of D1 (Output 1) is copied to U1, the F148 factory EDID is copied to U2.

8.16.6. Deleting an EDID from User Memory

Command and Response

- ▶ CALL /EDID:delete(<user>)
- ◀ mO /EDID:delete

Example

- ▶ CALL /EDID:delete(U1;U5)
- ◀ mO /EDID:delete

8.16.7. Resetting the Emulated EDIDs

Command and Response

- ▶ CALL /EDID:reset()
- ◀ mO /EDID:reset

Example

- ▶ CALL /EDID:reset()
- ◀ mO /EDID:reset

Calling this method switches all emulated EDIDs to a factory default one. See the table in the [Factory EDID List](#) section.

8.17. Health Status Monitoring Commands

8.17.1. Querying the Overall Health State of the Matrix

The query returns the overall health state of the matrix switcher, which equals the maximum value of the OverallHealthState parameter of each I/O board, the CECU, the HSMB, the Power Tray 1 and Power Tray 2.

#health

ATTENTION: In case of **WARNING** or **ERROR** result of the query, please download the system logs of the matrix immediately and power off the device as soon as possible.

Command and Response

- ▶ GET /HEALTH.OverallHealthState
- ◀ pr /HEALTH.OverallHealthState=<status>

Parameters

Parameter	Parameter description	Value	Value description
<status>	Overall health state of the matrix	OK	No active warning or error level log entry exists for the system or a device seated in the system.
		WARNING	Active warning level log entry exists AND no active error level log entry exists for the system or a device seated in the system.
		ERROR	Active error level log entry exists for the system or a device seated in the system.

Example

- ▶ GET /HEALTH.OverallHealthState
- ◀ pr /HEALTH.OverallHealthState=OK

8.17.2. Querying the Temperature Warnings

The query returns with a semi-colon separated list of the devices that have an active temperature warning.

ATTENTION: If a device has active temperature warning, please make sure the air ventilation of the matrix is correct.

Command and Response

- ▶ GET /HEALTH.TemperatureWarning
- ◀ pr /HEALTH.TemperatureWarning=<device1>;<device2>;...<deviceN>

Example

- ▶ GET /HEALTH.TemperatureWarning
- ◀ pr /HEALTH.TemperatureWarning=

8.17.3. Querying the Temperature Errors

The query returns with a semi-colon separated list of the devices that have an active temperature error.

WARNING! If a device has active temperature error, please make sure the air ventilation of the matrix is correct. Keeping the device in too high temperature long term may harm the electrical parts of the matrix.

Command and Response

- ▶ GET·/HEALTH.TemperatureError
- ◀ pr·/HEALTH.TemperatureError=<device1>;<device2>;...<deviceN>

Example

- ▶ GET /HEALTH.TemperatureError
- ◀ pr /HEALTH.TemperatureError=

8.17.4. Querying the Voltage Warnings

The query returns with a semi-colon separated list of the devices that have an active voltage warning.

Command and Response

- ▶ GET·/HEALTH.VoltageWarning
- ◀ pr·/HEALTH.VoltageWarning=<device1>;<device2>;...<deviceN>

Example

- ▶ GET /HEALTH.VoltageWarning
- ◀ pr /HEALTH.VoltageWarning=

8.17.5. Querying the Voltage Errors

The query returns with a semi-colon separated list of the devices that have an active voltage error.

WARNING! If a device has active voltage error, power off the device as soon as possible.

Command and Response

- ▶ GET·/HEALTH.VoltageError
- ◀ pr·/HEALTH.VoltageError=<device1>;<device2>;...<deviceN>

Example

- ▶ GET /HEALTH.VoltageError
- ◀ pr /HEALTH.VoltageError=

8.17.6. Querying the Current Warnings

The query returns with a semi-colon separated list of the devices that have an active current warning.

Command and Response

- ▶ GET·/HEALTH.CurrentWarning
- ◀ pr·/HEALTH.CurrentWarning=<device1>;<device2>;...<deviceN>

Example

- ▶ GET /HEALTH.CurrentWarning
- ◀ pr /HEALTH.CurrentWarning=

8.17.7. Querying the Current Errors

The query returns with a semi-colon separated list of the devices that have an active current error.

WARNING! If a device has active current error, power off the device as soon as possible.

Command and Response

- ▶ GET·/HEALTH.CurrentError
- ◀ pr·/HEALTH.CurrentError=<device1>;<device2>;...<deviceN>

Example

- ▶ GET /HEALTH.CurrentError
- ◀ pr /HEALTH.CurrentError=

8.17.8. Querying the Fan Warnings

The query returns with a semi-colon separated list of the devices that have an active system fan warning.

Command and Response

- ▶ GET·/HEALTH.FanWarning
- ◀ pr·/HEALTH.FanWarning=<fan1>;<fan2>;...<fanN>

Example

- ▶ GET /HEALTH.FanWarning
- ◀ pr /HEALTH.FanWarning=

8.17.9. Querying the Fan Errors

The query returns with a semi-colon separated list of the devices that have an active system fan error.

Command and Response

- ▶ GET /HEALTH.FanError
- ◀ pr /HEALTH.FanError=<fan1>;<fan2>;...<fanN>

Example

- ▶ GET /HEALTH.FanError
- ◀ pr /HEALTH.FanError=

8.17.10. Querying the PSU Drawer Warnings

The query returns with a semi-colon separated list of the devices that have an active PSU warning.

Command and Response

- ▶ GET /HEALTH.PsuWarning
- ◀ pr /HEALTH.PsuWarning=<PSU1>;<PSU2>

Example

- ▶ GET /HEALTH.PsuWarning
- ◀ pr /HEALTH.PsuWarning=

8.17.11. Querying the PSU Drawer Errors

The query returns with a semi-colon separated list of the devices that have an active PSU error.

WARNING! If a device has active PSU drawer error, power off the device as soon as possible.

Command and Response

- ▶ GET /HEALTH.PsuError
- ◀ pr /HEALTH.PsuError=<PSU1>;<PSU2>

Example

- ▶ GET /HEALTH.PsuError
- ◀ pr /HEALTH.PsuError=

8.17.12. Querying the Health State of an I/O Board

The query returns with the actual health status information about the selected I/O board.

Command and Response

- ▶ GETALL /HEALTH/<board>
- ◀ pr /HEALTH/<board>.Status=<status>
- ◀ pr /HEALTH/<board>.ProductName=<product_name>
- ◀ pr /HEALTH/<board>.SerialNumber=<serial_number>
- ◀ pr /HEALTH/<board>.PartNumber=<part_number>
- ◀ pr /HEALTH/<board>.UpTime=<second>
- ◀ pr /HEALTH/<board>.TemperatureState=<status>
- ◀ pr /HEALTH/<board>.VoltageState=<status>
- ◀ pr /HEALTH/<board>.OverallHealthState=<status>
- ◀ pr /HEALTH/<board>.Temperature0=<temperature0>
- ◀ pr /HEALTH/<board>.Temperature1=<temperature1>
- ◀ pr /HEALTH/<board>.Temperature2=<temperature2>
- ◀ pr /HEALTH/<board>.Temperature3=<temperature3>
- ◀ pr /HEALTH/<board>.Temperature4=<temperature4>
- ◀ pr /HEALTH/<board>.Voltage0=<voltage0>
- ◀ pr /HEALTH/<board>.Voltage1=<voltage1>
- ◀ pr /HEALTH/<board>.Voltage2=<voltage2>
- ◀ pr /HEALTH/<board>.Voltage3=<voltage3>
- ◀ pr /HEALTH/<board>.Voltage4=<voltage4>

Parameters

Identifier	Parameter description	Value	Value description
<board>	The identifier of the board.	IB1...IB6	Input board ID, the values can be IB1, IB2, IB3, IB4, IB5 or IB6.
		OB1...OB6	Output board ID, the values can be OB1, OB2, OB3, OB4, OB5 or OB6.
		LS1...LS4	Auxiliary (LS - Low Speed) board ID, the values can be LS1, LS2, LS3, or LS4.

Layout of the Matrix

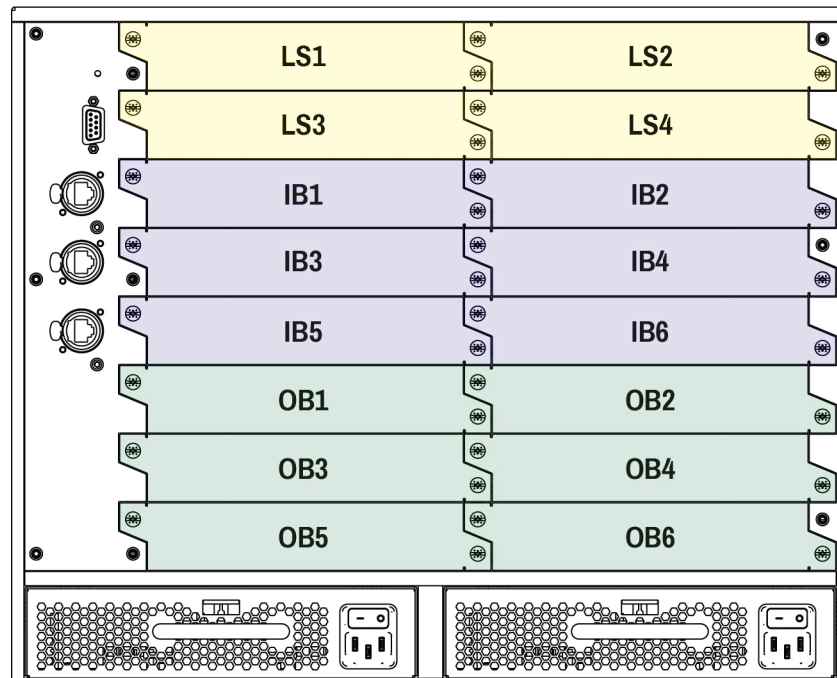

Example

```

▶ GETALL /HEALTH/IB5
◀ pr /HEALTH/IB5.Status=Operational
◀ pr /HEALTH/IB5.ProductName=MX2M-DH-4DP12-IB
◀ pr /HEALTH/IB5.SerialNumber=00006522
◀ pr /HEALTH/IB5.PartNumber=91120049
◀ pr /HEALTH/IB5.UpTime=343393
◀ pr /HEALTH/IB5.TemperatureState=Ok
◀ pr /HEALTH/IB5.VoltageState=Ok
◀ pr /HEALTH/IB5.OverallHealthState=Ok
◀ pr /HEALTH/IB5.Temperature0=45.30 C;0.00;115.00;0.00;125.00;34.58;46.52;
◀ pr /HEALTH/IB5.Voltage0=5.01 V;4.85;5.15;4.75;5.25;4.96;5.01;
◀ pr /HEALTH/IB5.Voltage1=3.30 V;3.20;3.40;3.14;3.47;3.30;3.33;
◀ pr /HEALTH/IB5.Voltage2=1.79 V;1.75;1.85;1.71;1.89;1.79;1.79;
◀ pr /HEALTH/IB5.Voltage3=1.02 V;0.97;1.03;0.95;1.05;1.00;1.02;
◀ pr /HEALTH/IB5.Voltage4=1.00 V;0.97;1.03;0.95;1.05;0.99;1.00;

```

8.17.13. Querying the Health State of a PSU Drawer

The query returns with the actual health status information about the selected PSU drawer.

Command and Response

```

▶ GETALL /HEALTH/<PSU>
◀ pr /HEALTH/<PSU>.Enabled=<logical_value>
◀ pr /HEALTH/<PSU>.FanSpeed0=<fanspeed>
◀ pr /HEALTH/<PSU>.Temperature0=<temperature>
◀ pr /HEALTH/<PSU>.Current0=<current0>
◀ pr /HEALTH/<PSU>.Current1=<current1>
◀ pr /HEALTH/<PSU>.DcOk0=<logical_value>
◀ pr /HEALTH/<PSU>.DcOk1=<logical_value>
◀ pr /HEALTH/<PSU>.PowerGood0=<logical_value>
◀ pr /HEALTH/<PSU>.PowerGood1=<logical_value>
◀ pr /HEALTH/<PSU>.TemperatureState=<status>
◀ pr /HEALTH/<PSU>.CurrentState=<status>
◀ pr /HEALTH/<PSU>.FanState=<status>
◀ pr /HEALTH/<PSU>.PowerDrawerState=<status>
◀ pr /HEALTH/<board>.OverallHealthState=<status>
◀ pr /HEALTH/<board>.Status=<status>
◀ pr /HEALTH/<PSU>.ProductName=<product_name>
◀ pr /HEALTH/<PSU>.SerialNumber=<serial_number>
◀ pr /HEALTH/<PSU>.PartNumber=<part_number>

```

Parameters

Identifier	Parameter description	Value	Value description
<PSU>	The identifier of the PSU drawer.	POWERDRAWER1	PSU drawer 1
		POWERDRAWER2	PSU drawer 2

Layout of the Matrix

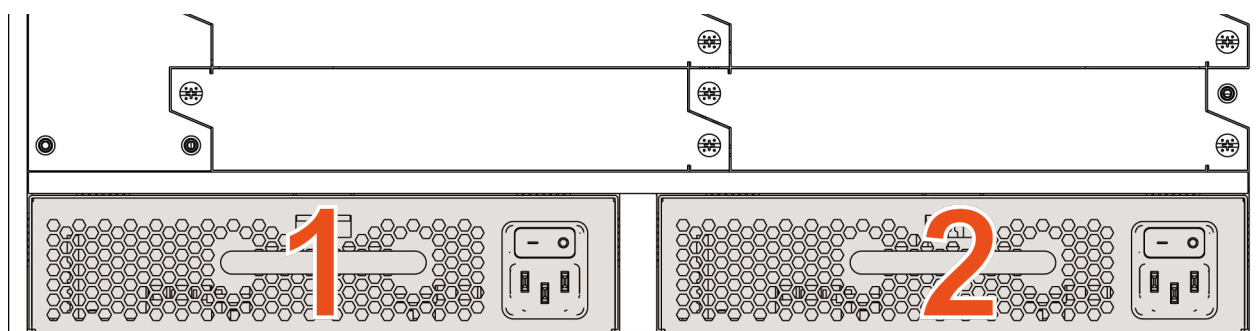

Example

```

▶ GETALL /HEALTH/POWERDRAWER1
◀ pr /HEALTH/POWERDRAWER1.Enabled=true
◀ pr /HEALTH/POWERDRAWER1.FanSpeed0=0.00 RPM;10.00;65535.00;0.00;65535.00;0.00;0.00
◀ pr /HEALTH/POWERDRAWER1.Temperature0=0.00 C;0.00;100.00;0.00;110.00;0.00;0.00
◀ pr /HEALTH/POWERDRAWER1.Current0=59.11 A;0.00;38.00;0.00;42.00;59.11;59.11
◀ pr /HEALTH/POWERDRAWER1.Current1=0.00 A;0.00;14.00;0.00;15.60;0.00;0.00
◀ pr /HEALTH/POWERDRAWER1.DcOk0=true
◀ pr /HEALTH/POWERDRAWER1.DcOk1=true
◀ pr /HEALTH/POWERDRAWER1.PowerGood0=true
◀ pr /HEALTH/POWERDRAWER1.PowerGood1=true
◀ pr /HEALTH/POWERDRAWER1.TemperatureState=OK
◀ pr /HEALTH/POWERDRAWER1.CurrentState=OK
◀ pr /HEALTH/POWERDRAWER1.FanState=OK
◀ pr /HEALTH/POWERDRAWER1.PowerDrawerState=Operational
◀ pr /HEALTH/POWERDRAWER1.OverallHealthState=OK
◀ pr /HEALTH/POWERDRAWER1.Status=Operational
◀ pr /HEALTH/POWERDRAWER1.ProductName=MX2M-PSU-500-F
◀ pr /HEALTH/POWERDRAWER1.SerialNumber=87654321
◀ pr /HEALTH/POWERDRAWER1.PartNumber=

```

8.17.14. Querying the Health State of the HSMB

The query returns with the actual health status information about the High Speed Motherboard (HSMB).

Command and Response

```

▶ GETALL /HEALTH/HSMB
◀ pr /HEALTH/HSMB.Voltage0_1V0=<voltage0>
◀ pr /HEALTH/HSMB.Voltage1_1V2=<voltage1>
◀ pr /HEALTH/HSMB.Voltage2_1V5=<voltage2>
◀ pr /HEALTH/HSMB.Voltage3_3V3=<voltage3>
◀ pr /HEALTH/HSMB.Voltage4_5V0=<voltage4>
◀ pr /HEALTH/HSMB.Voltage5_12V0=<voltage5>
◀ pr /HEALTH/HSMB.Voltage6_48V0=<voltage6>
◀ pr /HEALTH/HSMB.Temperature0=<temperature0>
◀ pr /HEALTH/HSMB.Temperature1=<temperature1>
◀ pr /HEALTH/HSMB.Temperature2=<temperature2>
◀ pr /HEALTH/HSMB.FanSpeed0=<fanspeed0>
◀ pr /HEALTH/HSMB.FanSpeed1=<fanspeed1>
◀ pr /HEALTH/HSMB.FanSpeed2=<fanspeed2>
◀ pr /HEALTH/HSMB.UnevenCurrentShare=<logical_value>
◀ pr /HEALTH/HSMB.BoardsInRightSlotState=<status>
◀ pr /HEALTH/HSMB.TemperatureState=<status>
◀ pr /HEALTH/HSMB.VoltageState=<status>
◀ pr /HEALTH/HSMB.FanState=<status>
◀ pr /HEALTH/HSMB.OverallHealthState=<status>

```

Example

```

▶ GETALL /HEALTH/HSMB
◀ pr /HEALTH/HSMB.Voltage0_1V0=1.04 V;1.02;1.08;1.00;1.10;1.03;1.04
◀ pr /HEALTH/HSMB.Voltage1_1V2=1.17 V;1.16;1.24;1.14;1.26;1.17;1.17
◀ pr /HEALTH/HSMB.Voltage2_1V5=1.48 V;1.46;1.55;1.43;1.58;1.48;1.48
◀ pr /HEALTH/HSMB.Voltage3_3V3=3.32 V;3.20;3.40;3.14;3.47;3.32;3.32
◀ pr /HEALTH/HSMB.Voltage4_5V0=5.06 V;4.95;5.25;4.85;5.36;5.06;5.12
◀ pr /HEALTH/HSMB.Voltage5_12V0=0.26 V;11.50;12.60;11.00;13.00;0.26;0.26
◀ pr /HEALTH/HSMB.Voltage6_48V0=0.00 V;46.00;52.00;44.00;56.00;0.00;0.00
◀ pr /HEALTH/HSMB.Temperature0=65.00 C;0.00;75.00;0.00;85.00;0.00;72.50
◀ pr /HEALTH/HSMB.Temperature1=72.50 C;0.00;75.00;0.00;85.00;65.00;72.50
◀ pr /HEALTH/HSMB.Temperature2=72.50 C;0.00;75.00;0.00;85.00;65.00;72.50
◀ pr /HEALTH/HSMB.FanSpeed0=0.00 RPM;10.00;65535.00;0.00;65535.00;0.00;0.00

```

- ◀ pr /HEALTH/HSMB.FanSpeed1=0.00 RPM;10.00;65535.00;0.00;65535.00;0.00;0.00
- ◀ pr /HEALTH/HSMB.FanSpeed2=0.00 RPM;10.00;65535.00;0.00;65535.00;0.00;0.00
- ◀ pr /HEALTH/HSMB.UnevenCurrentShare=false
- ◀ pr /HEALTH/HSMB.BoardsInRightSlotState=OK
- ◀ pr /HEALTH/HSMB.TemperatureState=OK
- ◀ pr /HEALTH/HSMB.VoltageState=OK
- ◀ pr /HEALTH/HSMB.FanState=OK
- ◀ pr /HEALTH/HSMB.OverallHealthState=OK

8.17.15. Querying the Health State of the CECU

The query returns with the actual health status information about the Central Electronic Control Unit (CECU).

Command and Response

- ▶ GETALL /HEALTH/CECU
- ◀ pr /HEALTH/CECU.Temperature0=<temperature>
- ◀ pr /HEALTH/CECU.TemperatureState=<status>
- ◀ pr /HEALTH/CECU.OverallHealthState=<status>

Example

- ▶ GETALL /HEALTH/CECU
- ◀ pr /HEALTH/CECU.Temperature0=47.72 C;0.00;65.00;0.00;70.00;44.24;53.52
- ◀ pr /HEALTH/CECU.TemperatureState=OK
- ◀ pr /HEALTH/CECU.OverallHealthState=OK

8.18. Network Configuration

ATTENTION: Calling the ApplySettings() method after the network setting is always required. See the details in the [Applying the Network Settings](#) section. #network #dhcp #ipaddress

8.18.1. Querying the DHCP State

Command and Response

- ▶ GET /MANAGEMENT/NETWORK.DhcpEnabled
- ◀ pw /MANAGEMENT/NETWORK.DhcpEnabled=<logical_value>

Parameters

The <logical_value> can be **true** or **false**.

Example

- ▶ GET /MANAGEMENT/NETWORK.DhcpEnabled
- ◀ pw /MANAGEMENT/NETWORK.DhcpEnabled=true

8.18.2. Changing the DHCP State

Command and Response

- ▶ SET /MANAGEMENT/NETWORK.DhcpEnabled=<logical_value>
- ◀ pw /MANAGEMENT/NETWORK.DhcpEnabled=<logical_value>

Parameters

The <logical_value> can be set to **true** or **false**.

Example

- ▶ SET /MANAGEMENT/NETWORK.DhcpEnabled=false
- ◀ pw /MANAGEMENT/NETWORK.DhcpEnabled=false

8.18.3. Querying the IP Address

Command and Response

- ▶ GET /MANAGEMENT/NETWORK.IpAddress
- ◀ pr /MANAGEMENT/NETWORK.IpAddress=<IP_address>

Example

- ▶ GET /MANAGEMENT/NETWORK.IpAddress
- ◀ pr /MANAGEMENT/NETWORK.IpAddress=192.168.0.100

8.18.4. Changing the IP Address (Static)

Command and Response

- ▶ SET /MANAGEMENT/NETWORK.StaticIpAddress=<IP_address>
- ◀ pw /MANAGEMENT/NETWORK.StaticIpAddress=<IP_address>

Example

- ▶ SET /MANAGEMENT/NETWORK.StaticIpAddress=192.168.0.85
- ◀ pw /MANAGEMENT/NETWORK.StaticIpAddress=192.168.0.85

8.18.5. Querying the Subnet Mask

Command and Response

- ▶ GET /MANAGEMENT/NETWORK.NetworkMask
- ◀ pr /MANAGEMENT/NETWORK.NetworkMask=<netmask>

Example

- ▶ GET /MANAGEMENT/NETWORK.NetworkMask
- ◀ pr /MANAGEMENT/NETWORK.NetworkMask=255.255.255.0

8.18.6. Changing the Subnet Mask (Static)

Command and Response

- ▶ SET /MANAGEMENT/NETWORK.StaticNetworkMask=<netmask>
- ◀ pw /MANAGEMENT/NETWORK.StaticNetworkMask=<netmask>

Example

- ▶ SET /MANAGEMENT/NETWORK.StaticNetworkMask=255.255.255.0
- ◀ pw /MANAGEMENT/NETWORK.StaticNetworkMask=255.255.255.0

8.18.7. Querying the Gateway Address

Command and Response

- ▶ GET /MANAGEMENT/NETWORK.GatewayAddress
- ◀ pr /MANAGEMENT/NETWORK.GatewayAddress=<gw_address>

Example

- ▶ GET /MANAGEMENT/NETWORK.GatewayAddress
- ◀ pr /MANAGEMENT/NETWORK.GatewayAddress=192.168.0.1

8.18.8. Changing the Gateway Address (Static)

Command and Response

- ▶ SET /MANAGEMENT/NETWORK.StaticGatewayAddress=<gw_address>
- ◀ pw /MANAGEMENT/NETWORK.StaticGatewayAddress=<gw_address>

Example

- ▶ SET /MANAGEMENT/NETWORK.StaticGatewayAddress=192.168.0.1
- ◀ pw /MANAGEMENT/NETWORK.StaticGatewayAddress=192.168.0.1

8.18.9. Applying the Network Settings

Command and Response

- ▶ CALL /MANAGEMENT/NETWORK:ApplySettings()
- ◀ m0 /MANAGEMENT/NETWORK:ApplySettings

Example

- ▶ CALL /MANAGEMENT/NETWORK:ApplySettings()
- ◀ m0 /MANAGEMENT/NETWORK:ApplySettings

8.19. RS-232 Port Configuration

8.19.1. Enabling/Disabling the Port

Command and Response

- ▶ SET /MANAGEMENT/SERIAL.Enabled=<logical_value>
- ◀ pw /MANAGEMENT/SERIAL.Enabled=<logical_value>

Parameters

Parameter	Parameter description	Value	Value description
<logical_value>	Port enable/disable setting	true	The port is enabled.
		false	The port is disabled.

Example

- ▶ SET /MANAGEMENT/SERIAL.Enabled=true
- ◀ pw /MANAGEMENT/SERIAL.Enabled=true

8.19.2. Setting the BAUD Rate

Command and Response

- ▶ SET·/MANAGEMENT/SERIAL.Baudrate=<baudrate>
- ◀ pw·/MANAGEMENT/SERIAL.Baudrate=<baudrate>

Parameters

Parameter	Parameter description	Value	Value description
<baudrate>	Baud rate value	0	0
		200	200
		300	300
		600	600
		1200	1200
		1800	1800
		2400	2400
		4800	4800
		9600	9600
		19200	19200
		38400	38400
		57600	57600
		115200	115200

Example

- ▶ SET /MANAGEMENT/SERIAL.Baudrate=57600
- ◀ pw /MANAGEMENT/SERIAL.Baudrate=57600

8.19.3. Setting the Databits

Command and Response

- ▶ SET·/MANAGEMENT/SERIAL.DataBits=<databits>
- ◀ pw·/MANAGEMENT/SERIAL.DataBits=<databits>

Parameters

Parameter	Parameter description	Value	Value description
<databits>	Databits value	8	8 databits
		9	9 databits

Example

- ▶ SET /MANAGEMENT/SERIAL.DataBits=8
- ◀ pw /MANAGEMENT/SERIAL.DataBits=8

8.19.4. Setting the Parity

Command and Response

- ▶ SET·/MANAGEMENT/SERIAL.Parity=<parity>
- ◀ pw·/MANAGEMENT/SERIAL.Parity=<parity>

Parameters

Parameter	Parameter description	Value	Value description
<parity>	Parity value	None	None
		Odd	Odd
		Even	Even
		Mark	Mark
		Space	Space

Example

- ▶ SET /MANAGEMENT/SERIAL.Parity=Even
- ◀ pw /MANAGEMENT/SERIAL.Parity=Even

8.19.5. Setting the Stopbits

Command and Response

- ▶ SET·/MANAGEMENT/SERIAL.StopBits=<stopbits>
- ◀ pw·/MANAGEMENT/SERIAL.StopBits=<stopbits>

Parameters

Parameter	Parameter description	Value	Value description
<stopbits>	Stop bits value	1	1
		2	2

Example

- ▶ SET /MANAGEMENT/SERIAL.StopBits=1
- ◀ pw /MANAGEMENT/SERIAL.StopBits=1

8.19.6. Setting the Protocol

Command and Response

- ▶ SET /MANAGEMENT/SERIAL.Protocol=<protocol>
- ◀ pw /MANAGEMENT/SERIAL.Protocol=<protocol>

Parameters

Parameter	Parameter description	Value	Value description
<protocol>	Command protocol on the serial port	LW2	Lightware LW2 command protocol
		LW3	Lightware LW3 command protocol
		P#2	Third-party command protocol

Example

- ▶ SET /MANAGEMENT/SERIAL.Protocol=LW3
- ◀ pw /MANAGEMENT/SERIAL.Protocol=LW3

8.19.7. Recalling Factory Default Settings on the Serial Port

Command and Response

- ▶ CALL /MANAGEMENT/SERIAL:factoryDefault()
- ◀ mO /MANAGEMENT/SERIAL:factoryDefault=

Example

- ▶ CALL /MANAGEMENT/SERIAL:factoryDefault()
- ◀ mO /MANAGEMENT/SERIAL:factoryDefault=

INFO: See the factory default values for the RS-232 port in the [Factory Default Settings](#) section.

8.20. Sending CEC Commands

INFO: The hidden first 2 bytes of the CEC command are static, they refer to the logical address of the sender and the addressee. When the port is input, it is always 04 (from TV to Playback device 1); when the port is output, it is always 40 (from Playback device 1 to TV). Broadcast addressing is also possible (in this case it is 0F or 4F). #cec

INFO: The port numbering of the relevant I/O boards can be found in the [Video Input/Output Port Numbering](#) section.

The following settings are valid only for the following input and output boards:

- MX2M-4HDMI20-IB
- MX2M-4TPX-IB
- MX2M-4OPTJ-IB
- MX2M-4HDMI20-OB
- MX2M-4OPTJ-OB

8.20.1. Sending a CEC Command in Text Format

Command and Response

- ▶ CALL /MEDIA/PORTS/VIDEO/<in|out>/PARAMETERS/CEC:send(<command>)
- ◀ mO /MEDIA/PORTS/VIDEO/<in|out>/PARAMETERS/CEC:send

Parameters

The followings are accepted as <command>:

image_view_on	standby	text_view_on	active_source	give_power_status
get_cec_version	set_osd	clear_osd		

Example

- ▶ CALL /MEDIA/PORTS/VIDEO/01/PARAMETERS/CEC:send(power_on)
- ◀ mO /MEDIA/PORTS/VIDEO/01/PARAMETERS/CEC:send

8.20.2. Press&Release Commands

CEC commands below are called 'push-button commands', like a button in a remote controller, e.g. volume up/down. When the CEC command is sent, the 'release' command is also sent in the background. Certain devices require this feature for the proper working, but this is necessary only for push-button commands.

Command and Response

- ▶ CALL /MEDIA/PORTS/VIDEO/<in|out>/PARAMETERS/CEC:sendClick(<command>)
- ◀ mO /MEDIA/PORTS/VIDEO/<in|out>/PARAMETERS/CEC:sendClick

Parameters

The following are accepted as a <command>:

ok	number_2	input_select	rewind	select_media_4
back	number_3	display_info	fast_forward	select_media_5
up	number_4	power_legacy	eject	power_toggle
down	number_5	page_up	skip_forward	power_on
left	number_6	page_down	skip_backward	power_off
right	number_7	volume_up	3d_mode	stop_function
root_menu	number_8	volume_down	stop_record	f1
setup_menu	number_9	mute_toggle	pause_record	f2
contents_menu	dot	mute	play_forward	f3
favorite_menu	enter	unmute	play_reverse	f4
media_top_menu	clear	play	select_next_media	
media_context_menu	channel_up	stop	select_media_1	
number_0	channel_down	pause	select_media_2	
number_1	sound_select	record	select_media_3	

Example

- ▶ CALL /MEDIA/PORTS/VIDEO/O1/PARAMETERS/CEC:sendClick(play)
- ◀ mO /MEDIA/PORTS/VIDEO/O1/PARAMETERS/CEC:sendClick

8.20.3. Sending an OSD String

Sending the OSD string consists of two steps. First, set the **CEC.OsdString** property with the desired text, after that call the **CEC.send(set_osd)** method.

Step 1 – Setting the CEC.OsdString Property

Command and Response

- ▶ SET /MEDIA/PORTS/VIDEO/<in|out>/PARAMETERS/CEC.OsdString=<text>
- ◀ pw /MEDIA/PORTS/VIDEO/<in|out>/PARAMETERS/CEC.OsdString=<text>

Parameters

<text> Letters (A-Z) and (a-z), hyphen (-), underscore (_), numbers (0-9), and dot (.). Max length: 14 characters.

Example

- ▶ SET /MEDIA/PORTS/VIDEO/I1/PARAMETERS/CEC.OsdString=Lightware
- ◀ pw /MEDIA/PORTS/VIDEO/I1/PARAMETERS/CEC.OsdString=Lightware

Step 2 – Call the CEC.send(set_osd) method

Command and Response

- ▶ CALL /MEDIA/PORTS/VIDEO/<in|out>/PARAMETERS/CEC:send(set_osd)
- ◀ mO /MEDIA/PORTS/VIDEO/<in|out>/PARAMETERS/CEC:send

Example

- ▶ CALL /MEDIA/PORTS/VIDEO/I1/PARAMETERS/CEC:send(set_osd)
- ◀ mO /MEDIA/PORTS/VIDEO/I1/PARAMETERS/CEC:send

8.20.4. Sending a CEC Command in Hexadecimal Format

Command and Response

- ▶ CALL /MEDIA/PORTS/VIDEO/<in|out>/PARAMETERS/CEC:sendHex(<hex_code>)
- ◀ mO /MEDIA/PORTS/VIDEO/<in|out>/PARAMETERS/CEC:sendHex

Parameters

<hex_code> Accepted command is max. 30 characters long (15 byte) in Hexadecimal format.

Example

- ▶ CALL /MEDIA/PORTS/VIDEO/I1/PARAMETERS/CEC:sendHex(8700E091)
- ◀ mO /MEDIA/PORTS/VIDEO/I1/PARAMETERS/CEC:sendHex

8.21. Firmware Updating of the I/O Boards

The firmware package files of all available MX2M series I/O boards are built-in into the firmware package of the MX2M matrix frame. The updating procedure can be applied inside the frame without using any external application like Lightware Device Updater V2 (LDU2).

Parameters

Identifier	Parameter description	Value	Value description
<board>	The identifier of the board.	IB1...IB6	Input board ID, the values can be IB1, IB2, IB3, IB4, IB5 or IB6.
		OB1...OB6	Output board ID, the values can be OB1, OB2, OB3, OB4, OB5 or OB6.
		LS1...LS4	Auxiliary (LS - Low Speed) board ID, the values can be LS1, LS2, LS3 or LS4.

8.21.1. Querying the Firmware Version of the I/O Board

Command and Response *#firmwareversion*

- ▶ GET /SYS/<board>.PackageVersion
- ◀ pr /SYS/<board>.PackageVersion=<firmware_version>

Example

- ▶ GET /SYS/LS1.PackageVersion
- ◀ pr /SYS/LS1.PackageVersion=1.0.0b20

8.21.2. Launching the Firmware Update Procedure

Calling the method launches the firmware update procedure on the selected I/O board.

Command and Response

- ▶ CALL /SYS/<board>.updateFirmware()
- ◀ mO /SYS/<board>.updateFirmware=

Example

- ▶ CALL /SYS/IB1.updateFirmware()
- ◀ mO /SYS/IB1.updateFirmware=

8.21.3. Cancelling the Firmware Update Procedure

Calling the method cancels the running firmware update procedure on the selected I/O board.

Command and Response

- ▶ CALL /SYS/<board>.cancelFirmwareUpdate()
- ◀ mO /SYS/<board>.cancelFirmwareUpdate=

Example

- ▶ CALL /SYS/OB1.cancelFirmwareUpdate()
- ◀ mO /SYS/OB1.cancelFirmwareUpdate=

8.21.4. Querying the Update Progress Status

The query returns with the logical value that tells whether there is a board in the matrix undergoing a firmware update or not.

Command and Response

- ▶ GET /SYS/UPDATE.BoardUpdateInProgress
- ◀ pr /SYS/UPDATE.BoardUpdateInProgress=<logical_value>

Parameters

Identifier	Parameter description	Value	Value description
<logical_value>	Update in progress	true	One or more I/O boards are undergoing a firmware update.
		false	No I/O board is undergoing a firmware update.

Example

- ▶ GET /SYS/UPDATE.UpdateInProgress
- ◀ pr /SYS/UPDATE.UpdateInProgress=true

8.21.5. Querying the List of Updating Boards

The query returns with the list of the I/O boards that are currently undergoing a firmware update.

Command and Response

- ▶ GET /SYS/UPDATE.BoardsInUpdateState
- ◀ pr /SYS/UPDATE.BoardsInUpdateState=<board_slot1>;<board_slot2>;...<board_slotN>

Example

- ▶ GET /SYS/UPDATE.BoardsInUpdateState
- ◀ pr /SYS/UPDATE.BoardsInUpdateState=LS2;IB3;OB5

8.21.6. Querying the Overall Board Update Status

The query returns with the the overall progress of the board update.

Command and Response

- ▶ GET /SYS/UPDATE.BoardUpdateStatus
- ◀ pr /SYS/UPDATE.BoardUpdateStatus=<status>

Example

- ▶ GET /SYS/UPDATE.BoardUpdateStatus
- ◀ pr /SYS/UPDATE.BoardUpdateStatus=3/3

Explanation

Firmware upgrade procedure of three I/O boards out of three is successfully completed.

8.22. LW3 Protocol Commands - Quick Summary

System Commands

Querying the Product Name

- ▶ GET·/.ProductName

Setting the Device Label

- ▶ SET·/MANAGEMENT/LABEL/DeviceLabel=<Custom_name>

Querying the Serial Number

- ▶ GET·/.SerialNumber

Querying the Firmware Version

- ▶ GET·/MANAGEMENT/UID/PACKAGE.Version

Querying the Date and Time of the System

- ▶ GET·/MANAGEMENT/DATETIME.CurrentTime

Setting the Date and Time Manually

- ▶ CALL·/MANAGEMENT/DATETIME:setTime=<date_time>

Setting the Brightness of the LCD Screen

- ▶ SET·/SYS/CECU/LCD.Brightness=<parameter>

Control Lock of the LCD Menu

- ▶ SET·/SYS/CECU/LCD.ControlLock=<logical_value>

Adding License

- ▶ CALL·/MANAGEMENT/LICENSE:addLicense()

Removing License

- ▶ CALL·/MANAGEMENT/LICENSE:removeLicense()

Software Resetting the Device

- ▶ CALL·/SYS:softReset()

Rebooting the Device

- ▶ CALL·/SYS:reset()

Restoring the Factory Default Settings

- ▶ CALL·/SYS:factoryDefaults()

I/O Board Management

Querying the Status of a Board

- ▶ GET·/SYS/<board>.Status

Querying the Number of Seated I/O Boards

- ▶ GET·/SYS/UPDATE.NumberOfBoards

Querying the List of Seated I/O Boards

- ▶ GET·/SYS/UPDATE.BoardsInSeatedState

Querying the List of Operational I/O Boards

- ▶ GET·/SYS/UPDATE.BoardsInOperationalState

Querying the List of Failed I/O Boards

- ▶ GET·/SYS/UPDATE.BoardsInErrorState

Querying the Product Name of the I/O Board

- ▶ GET·/SYS/<board>.ProductName

Querying the Serial Number of the I/O Board

- ▶ GET·/SYS/<board>.SerialNumber

Querying the Firmware Version of the I/O Board

- ▶ GET·/SYS/<board>.PackageVersion

Rebooting the I/O Board

- ▶ CALL·/SYS/<board>:reset()

Video Switching and Crosspoint Settings

Querying the Video Crosspoint State

- ▶ GET·/MEDIA/XP/VIDEO.DestinationConnectionStatus

Switching an Input to an Output

- ▶ CALL·/MEDIA/XP/VIDEO:switch(<in>:<out>)

Disconnecting the Output from any Input

- ▶ CALL·/MEDIA/XP/VIDEO:switch(0:<out>)

Switching an Input to All Outputs

- ▶ CALL·/MEDIA/XP/VIDEO:switchAll(<in>)

Multiple Switching

- ▶ CALL·/MEDIA/XP/VIDEO:switchMulti(<out1_source>;<out2_source>;...;<out8_source>)

Muting a Video Input

- ▶ CALL·/MEDIA/XP/VIDEO:muteSource(<in>)

Unmuting a Video Input

- ▶ CALL·/MEDIA/XP/VIDEO:unmuteSource(<in>)

Locking a Video Input

- ▶ CALL·/MEDIA/XP/VIDEO:lockSource(<in>)

Unlocking a Video Input

- ▶ CALL·/MEDIA/XP/VIDEO:unlockSource(<in>)

Muting a Video Output

- ▶ CALL·/MEDIA/XP/VIDEO:muteDestination(<out>)

Unmuting a Video Output

- ▶ CALL·/MEDIA/XP/VIDEO:unmuteDestination(<out>)

Locking a Video Output

- ▶ CALL·/MEDIA/XP/VIDEO:lockDestination(<out>)

Unlocking a Video Output

- ▶ CALL·/MEDIA/XP/VIDEO:unlockDestination(<out>)

Audio Switching and Crosspoint Settings**Querying the Audio Crosspoint State**

- ▶ GET·/MEDIA/XP/AUDIO:DestinationConnectionStatus

Switching an Input to an Output

- ▶ CALL·/MEDIA/XP/AUDIO:switch(<in>:<out>)

Disconnecting the Output from any Input

- ▶ CALL·/MEDIA/XP/AUDIO:switch(0:<out>)

Switching an Input to All Outputs

- ▶ CALL·/MEDIA/XP/AUDIO:switchAll(<in>)

Multiple Switching

- ▶ CALL·/MEDIA/XP/AUDIO:switchMulti(<out1_source>;<out2_source>;...;<out8_source>)

Channel Mapping

- ▶ SET·/MEDIA/PORTS/AUDIO/<out>/PARAMETERS.MainOutputChannels=<left_channel>;<right_channel>

Muting an Audio Input

- ▶ CALL·/MEDIA/XP/AUDIO:muteSource(<in>)

Unmuting an Audio Input

- ▶ CALL·/MEDIA/XP/AUDIO:unmuteSource(<in>)

Locking an Audio Input

- ▶ CALL·/MEDIA/XP/AUDIO:lockSource(<in>)

Unlocking an Audio Input

- ▶ CALL·/MEDIA/XP/AUDIO:unlockSource(<in>)

Muting an Audio Output

- ▶ CALL·/MEDIA/XP/AUDIO:muteDestination(<out>)

Unmuting an Audio Output

- ▶ CALL·/MEDIA/XP/AUDIO:unmuteDestination(<out>)

Locking an Audio Output

- ▶ CALL·/MEDIA/XP/AUDIO:lockDestination(<out>)

Unlocking an Audio Output

- ▶ CALL·/MEDIA/XP/AUDIO:unlockDestination(<out>)

Video Source Port Settings - HDMI / OPTJ**Setting the HDCP**

- ▶ SET·/MEDIA/PORTS/VIDEO/<in>/PARAMETERS.HdcpVersion=<number>

Setting the Color Range

- ▶ SET·/MEDIA/PORTS/VIDEO/<in>/PARAMETERS.InputColorRangeMode=<colorange>

Setting the Hot Plug Detect (HPD)

- ▶ SET·/MEDIA/PORTS/VIDEO/<in>/PARAMETERS.EnableHPD=<hpd_setting>

Video Source Port Settings - DP**Setting the Maximum Lane Number**

- ▶ SET·/MEDIA/PORTS/VIDEO/<in>/PARAMETERS.DpMaxLaneCount=<lane>

Setting the Maximum Link Data Rate

- ▶ SET·/MEDIA/PORTS/VIDEO/<in>/PARAMETERS.DpMaxLinkRate=<data_rate>

Setting the DP Power

- ▶ SET·/MEDIA/PORTS/VIDEO/<in>/PARAMETERS.DpEnablePower=<logical_value>

Setting the Test Pattern Mode

- ▶ SET·/MEDIA/PORTS/VIDEO/<in>/PARAMETERS.DpTpgMode=<tpg_mode>

Setting the Color Space Conversion

- ▶ SET·/MEDIA/PORTS/VIDEO/<in>/PARAMETERS.DpConversion=<conversion_mode>

Setting the Color Range

- ▶ SET·/MEDIA/PORTS/VIDEO/<in>/PARAMETERS.InputColorRangeMode=<colorange>

Restarting Link Training

- ▶ CALL·/MEDIA/PORTS/VIDEO/<in>/PARAMETERS:DpLinkTrain()

Setting the Hot Plug Detect (HPD)

- ▶ SET·/MEDIA/PORTS/VIDEO/<in>/PARAMETERS.EnableHPD=<hpd_setting>

Setting the HDCP

- ▶ SET·/MEDIA/PORTS/VIDEO/<in>/PARAMETERS.HdcpVersion=<number>

Video Source Port Settings - TPX**Setting the HDCP**

- ▶ SET·/MEDIA/PORTS/VIDEO/<in>/PARAMETERS.HdcpVersion=<number>

Setting the Hot Plug Detect (HPD)

- ▶ SET·/MEDIA/PORTS/VIDEO/<in>/PARAMETERS.EnableHPD=<hpd_setting>

PoE (Power over Ethernet) Setting

- ▶ SET·/MEDIA/PORTS/VIDEO/<in>/PARAMETERS/POE.Enabled=<logical_value>

Video Destination Port Settings - HDMI / OPTJ / TPX**Setting the Color Space Conversion**

- ▶ SET·/MEDIA/PORTS/VIDEO/<out>/PARAMETERS.ColorSpaceSetting=<conversion_mode>

Setting the Signal Type

- ▶ SET·/MEDIA/PORTS/VIDEO/<out>/PARAMETERS.ForcedSignalType=<signal_type>

Setting the Power 5V

- ▶ SET·/MEDIA/PORTS/VIDEO/<out>/PARAMETERS.Enable5V=<power_mode>

Setting the HDCP Mode

- ▶ SET·/MEDIA/PORTS/VIDEO/<out>/PARAMETERS.HdcpMode=<HDCP_mode>

Setting the Audio Source

- ▶ SET·/MEDIA/PORTS/VIDEO/<out>/PARAMETERS.AudioSource=<audio_source>

PoE (Power over Ethernet) Setting

- ▶ SET·/MEDIA/PORTS/VIDEO/<out>/PARAMETERS/POE.Enabled=<logical_value>

Analog Audio Port Properties**Querying the Input Ports of the Board**

- ▶ GET·/SYS/<board>.AudioInput

Querying the Output Ports of the Board

- ▶ GET·/SYS/<board>.AudioOutput

Setting the Volume in dB

- ▶ SET·/MEDIA/PORTS/AUDIO/<in|out>/PARAMETERS.VoluedB=<volume>

Setting the Volume in dB by Steps

- ▶ CALL·/MEDIA/PORTS/AUDIO/<in|out>/PARAMETERS:stepVoluedB(<volume>)

Setting the Volume in Percent

- ▶ SET·/MEDIA/PORTS/AUDIO/<in|out>/PARAMETERS.VolumePercent=<percent>

Setting the Volume in Percent by Steps

- ▶ CALL·/MEDIA/PORTS/AUDIO/<in|out>/PARAMETERS:stepVolumePercent(<percent>)

Setting the Balance

- ▶ SET·/MEDIA/PORTS/AUDIO/<in|out>/PARAMETERS.Balance=<balance>

Setting the Balance by Steps

- ▶ CALL·/MEDIA/PORTS/AUDIO/<in|out>/PARAMETERS:stepBalance(<balance>)

Setting the Gain

- ▶ SET·/MEDIA/PORTS/AUDIO/<in>/PARAMETERS.Gain=<gain>

Dante® Audio Settings**Renaming the Channel Label**

- ▶ SET·/MEDIA/PORTS/AUDIO/<in|out>/PARAMETERS.ChannelLabel<number>=<channellabel>

Querying the Sample Rate

- ▶ GET·/MEDIA/PORTS/AUDIO/<in|out>/PARAMETERS.SampleRate

System Monitoring Commands**Querying Connected Device Presence**

- ▶ GET·/MEDIA/PORTS/VIDEO/<in|out>/PARAMETERS.Connected

Querying Video Signal Presence on a Port

- ▶ GET·/MEDIA/PORTS/VIDEO/<in|out>/PARAMETERS.SignalPresent

Querying the Signal Type

- ▶ GET·/MEDIA/PORTS/VIDEO/<in|out>/PARAMETERS.SignalType

Querying the Resolution of the Stream

- ▶ GET·/MEDIA/PORTS/VIDEO/<in|out>/PARAMETERS.Resolution

Querying the Total Size of the Stream

- ▶ GET·/MEDIA/PORTS/VIDEO/<in|out>/PARAMETERS.TotalSize

Querying Embedded Audio Presence

- ▶ GET·/MEDIA/PORTS/VIDEO/<in|out>/PARAMETERS.EmbeddedAudioPresent

Querying the Color Space of the Stream

- ▶ GET·/MEDIA/PORTS/VIDEO/<in|out>/PARAMETERS.ColorSpace

Querying the Color Range of the Stream

- ▶ GET-/MEDIA/PORTS/VIDEO/<in|out>/PARAMETERS.ColorRange

Querying the Color Depth of the Stream

- ▶ GET-/MEDIA/PORTS/VIDEO/<in|out>/PARAMETERS.ColorDepth

Querying the HDCP-encryption Presence

- ▶ GET-/MEDIA/PORTS/VIDEO/<in|out>/PARAMETERS.HdcpActive

Querying the HDCP-encryption Level of the Stream

- ▶ GET-/MEDIA/PORTS/VIDEO/<in|out>/PARAMETERS.ActiveHdcpVersion

Querying the Maximum Supported HDCP-encryption Level

- ▶ GET-/MEDIA/PORTS/VIDEO/<in|out>/PARAMETERS.MaxSupportedHdcpVersion

Querying the HDCP Error

- ▶ GET-/MEDIA/PORTS/VIDEO/<in|out>/PARAMETERS.HdcpError

Querying the TMDS Error Counters

- ▶ GET-/MEDIA/PORTS/VIDEO/<in|out>/PARAMETERS.TmdsErrorCounters

Querying the Audio Mismatch Status

- ▶ GET-/MEDIA/PORTS/AUDIO/<out>/PARAMETERS.AudioMismatch

Preset Handling**Creating a New Preset**

- ▶ CALL-/MEDIA/PRESET:create(<preset_name>,VIDEO)

Saving the Settings to an Existing Preset

- ▶ CALL-/MEDIA/PRESET/<preset_name>:save(1)

Loading a Preset

- ▶ CALL-/MEDIA/PRESET/<preset_name>:load()

Renaming a Preset

- ▶ CALL-/MEDIA/PRESET:rename(<Old_name>,<New_name>)

EDID Management**Querying the Emulated EDIDs**

- ▶ GET-/EDID.EdidStatus

Querying the Validity of a Dynamic EDID

- ▶ GET-/EDID/D/<dynamic>.Validity

Querying the Preferred Resolution of a User EDID

- ▶ GET-/EDID/U/<user>.PreferredResolution

Emulating an EDID on an Input Port

- ▶ CALL-/EDID:switch(<dynamic|user|factory>;<emulated>)

Copying an EDID to User Memory

- ▶ CALL-/EDID:copy(<dynamic|emulated|factory|user>;<user>)

Deleting an EDID from User Memory

- ▶ CALL-/EDID:delete(<user>)

Resetting the Emulated EDIDs

- ▶ CALL-/EDID:reset()

Health Status Monitoring Commands**Querying the Overall Health State of the Matrix**

- ▶ GET-/HEALTH.OverallHealthState

Querying the Temperature Warnings

- ▶ GET-/HEALTH.TemperatureWarning

Querying the Temperature Errors

- ▶ GET-/HEALTH.TemperatureError

Querying the Voltage Warnings

- ▶ GET-/HEALTH.VoltageWarning

Querying the Voltage Errors

- ▶ GET-/HEALTH.VoltageError

Querying the Current Warnings

- ▶ GET-/HEALTH.CurrentWarning

Querying the Current Errors

- ▶ GET-/HEALTH.CurrentError

Querying the Fan Warnings

- ▶ GET-/HEALTH.FanWarning

Querying the Fan Errors

- ▶ GET-/HEALTH.FanError

Querying the PSU Drawer Warnings

- ▶ GET-/HEALTH.PsuWarning

Querying the PSU Drawer Errors

- ▶ GET-/HEALTH.PsuError

Querying the Health State of an I/O Board

- ▶ GETALL·/HEALTH/<board>

Querying the Health State of a PSU Drawer

- ▶ GETALL·/HEALTH/<PSU>

Querying the Health State of the HSMB

- ▶ GETALL·/HEALTH/HSMB

Querying the Health State of the CECU

- ▶ GETALL·/HEALTH/CECU

Network Configuration**Querying the DHCP State**

- ▶ GET·/MANAGEMENT/NETWORK.DhcpEnabled

Changing the DHCP State

- ▶ SET·/MANAGEMENT/NETWORK.DhcpEnabled=<logical_value>

Querying the IP Address

- ▶ GET·/MANAGEMENT/NETWORK.IpAddress

Changing the IP Address (Static)

- ▶ SET·/MANAGEMENT/NETWORK.StaticIpAddress=<IP_address>

Querying the Subnet Mask

- ▶ GET·/MANAGEMENT/NETWORK.NetworkMask

Changing the Subnet Mask (Static)

- ▶ SET·/MANAGEMENT/NETWORK.StaticNetworkMask=<netmask>

Querying the Gateway Address

- ▶ GET·/MANAGEMENT/NETWORK.GatewayAddress

Changing the Gateway Address (Static)

- ▶ SET·/MANAGEMENT/NETWORK.StaticGatewayAddress=<gw_address>

Applying the Network Settings

- ▶ CALL·/MANAGEMENT/NETWORK:ApplySettings()

RS-232 Port Configuration**Enabling/Disabling the Port**

- ▶ SET·/MANAGEMENT/SERIAL.Enabled=<logical_value>

Setting the BAUD Rate

- ▶ SET·/MANAGEMENT/SERIAL.Baudrate=<baudrate>

Setting the Databits

- ▶ SET·/MANAGEMENT/SERIAL.DataBits=<databits>

Setting the Parity

- ▶ SET·/MANAGEMENT/SERIAL.Parity=<parity>

Setting the Stopbits

- ▶ SET·/MANAGEMENT/SERIAL.StopBits=<stopbits>

Setting the Protocol

- ▶ SET·/MANAGEMENT/SERIAL.Protocol=<protocol>

Recalling Factory Default Settings on the Serial Port

- ▶ CALL·/MANAGEMENT/SERIAL:factoryDefault()

Sending CEC Commands**Sending a CEC Command in Text Format**

- ▶ CALL·/MEDIA/PORTS/VIDEO/<in|out>/PARAMETERS/CEC:send(<command>)

Press&Release Commands

- ▶ CALL·/MEDIA/PORTS/VIDEO/<in|out>/PARAMETERS/CEC:sendClick(<command>)

Sending an OSD String

- ▶ SET·/MEDIA/PORTS/VIDEO/<in|out>/PARAMETERS/CEC.OsdString=<text>
- ▶ CALL·/MEDIA/PORTS/VIDEO/<in|out>/PARAMETERS/CEC:send(set_osd)

Sending a CEC Command in Hexadecimal Format

- ▶ CALL·/MEDIA/PORTS/VIDEO/<in|out>/PARAMETERS/CEC:sendHex(<hex_code>)

Firmware Updating of the I/O Boards**Querying the Firmware Version of the I/O Board**

- ▶ GET·/SYS/<board>.PackageVersion

Launching the Firmware Update Procedure

- ▶ CALL·/SYS/<board>:updateFirmware()

Cancelling the Firmware Update Procedure

- ▶ CALL·/SYS/<board>:cancelFirmwareUpdate()

Querying the Update Progress Status

- ▶ GET·/SYS/UPDATE.BoardUpdateInProgress

Querying the List of Updating Boards

- ▶ GET·/SYS/UPDATE.BoardsInUpdateState

Querying the Overall Board Update Status

- ▶ GET·/SYS/UPDATE.BoardUpdateStatus

9

Firmware Update

The MX2M series matrix switchers can be updated using Lightware Device Updater V2 (LDU2) software via Ethernet. The firmware pack with the necessary components (*.lfp2 file) for your specific product and the LDU2 application can be downloaded from the Support page of our website: www.lightware.com.

- | | |
|-----------------------------------|-----|
| ▶ Preparation | 119 |
| ▶ Running the Software | 120 |
| ▶ The Updating Steps | 121 |
| ▶ Updating Via GUI | 122 |
| ▶ Command Line Interface (CLI) | 123 |
| ▶ CLI Commands | 124 |
| ▶ If the Update is not successful | 128 |

ATTENTION: While the firmware is being updated, the normal operation mode is suspended, as the matrix is switched to bootload mode. Signal processing is not performed. Do not interrupt the firmware update. If any problem occurs, reboot the device and restart the process.

ATTENTION: The firmware update process has an effect on the configuration and the settings of the device. For more details, please see the [Keeping the Configuration Settings](#) section before the update.

9.1. Preparation

Most Lightware devices can be controlled over several interfaces (e.g. Ethernet, USB, RS-232). But the firmware can usually be updated over one dedicated interface, which is the Ethernet in most cases.

If you want to update the firmware of one or more devices, you need the following:

- **LFP2 file**,
- **LDU2 software** installed on your PC or Mac.

Both can be downloaded from www.lightware.com.

Optionally, you can download the **release notes** file in HTML format.

9.1.1. About the Firmware Package (LFP2 File)

All the necessary tools and binary files are packed into the LFP2 package file. You need only this file to do the update on your device.

- This allows the use of the same LFP2 package for different devices.
- The package contains all the necessary components, binary, and other files.
- The release notes is included in the LFP2 file, which is displayed in the window where you select the firmware package file in LDU2.

9.1.2. LDU2 Installation

ATTENTION: Minimum system requirement: 2 GB RAM. The minimum screen resolution is 1600x900.

ATTENTION: Certain ports are used for the communication in the background; please check the list in the [Applied Ports \(Network Settings\)](#) section.

INFO: The Windows, Mac and Linux applications have the same look and functionality.

Download the software from www.lightware.com/en/products/Software/lightware-device-updater-2.

Installation in case of Windows OS

Run the installer. If the User Account Control displays a pop-up message, click **Yes**.



Installation Modes

Normal install	Snapshot install
Available for Windows, macOS and Linux	Available for Windows
The installer can update only this instance	Cannot be updated
Only one updateable instance can exist for all users	More than one different version can be installed for each user

ATTENTION: Using the default Normal install is highly recommended.

INFO: If you have a previously installed version, you will be prompted to remove the old version before installing the new one.

Installation in case of macOS

Mount the DMG file by double clicking on it, and drag the LDU2 icon over the Applications icon to copy the program into the Applications folder. If you want to copy LDU2 into another location, just drag the icon over the desired folder.

ATTENTION: Please check the firewall settings on the macOS device. LDC needs to be added to the exceptions of the blocked software for the proper operation.

INFO: This type of installer is equal to the **Normal install** of Windows.

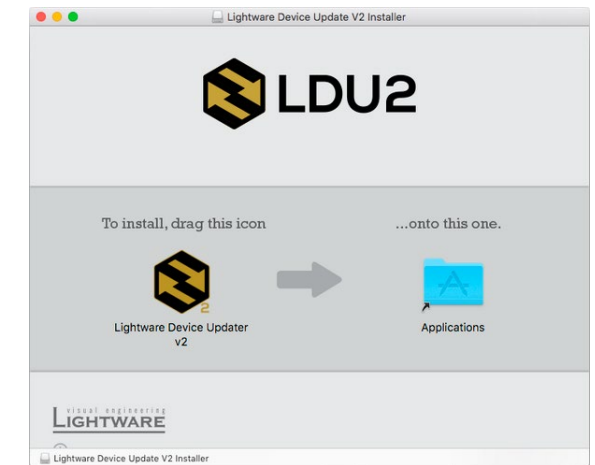

Installation in case of Linux

- Step 1.** Download the **archive file** (tar.gz) from www.lightware.com and unpack it to a temp folder.
- Step 2.** Run the **install_ldu2.sh** file in the temp folder. The script will install LDU2 into the following folder: HOME/.local/share/lightware/ldu2.
- Step 3.** The folder above will contain this file: **LightwareDeviceUpdaterV2.sh**, which can be used to start LDU2.



9.2. Running the Software

ATTENTION: The computer that runs LDU2 and the target device (that will be updated) must be in the same subnet. The update cannot be performed behind a firewall or gateway.

You have two options:

- Starting the LDU2 by double-clicking on the shortcut/program file, or
- Double-clicking on an LFP2 file.

9.2.1. LDU2 Interfaces

The software can be used over:

- The Graphical User Interface (GUI), or by
- The Command Line Interface (CLI).

LDU2 Auto-Update

At startup, the software checks whether a newer version is available on the web.

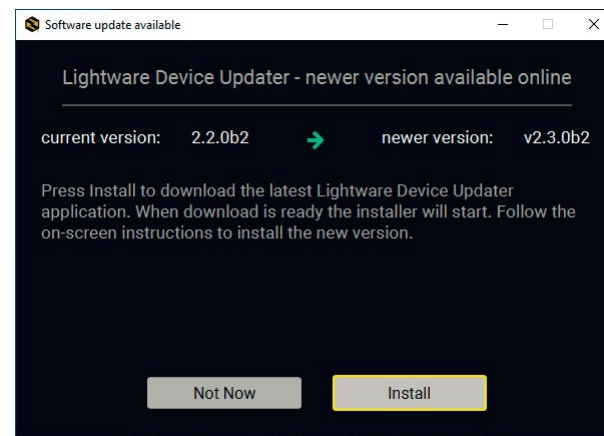

Main Screen

When the software is started by the shortcut, the device discovery screen appears. Press the **Discover Devices** button to start finding the Lightware devices:

DISCOVER DEVICES

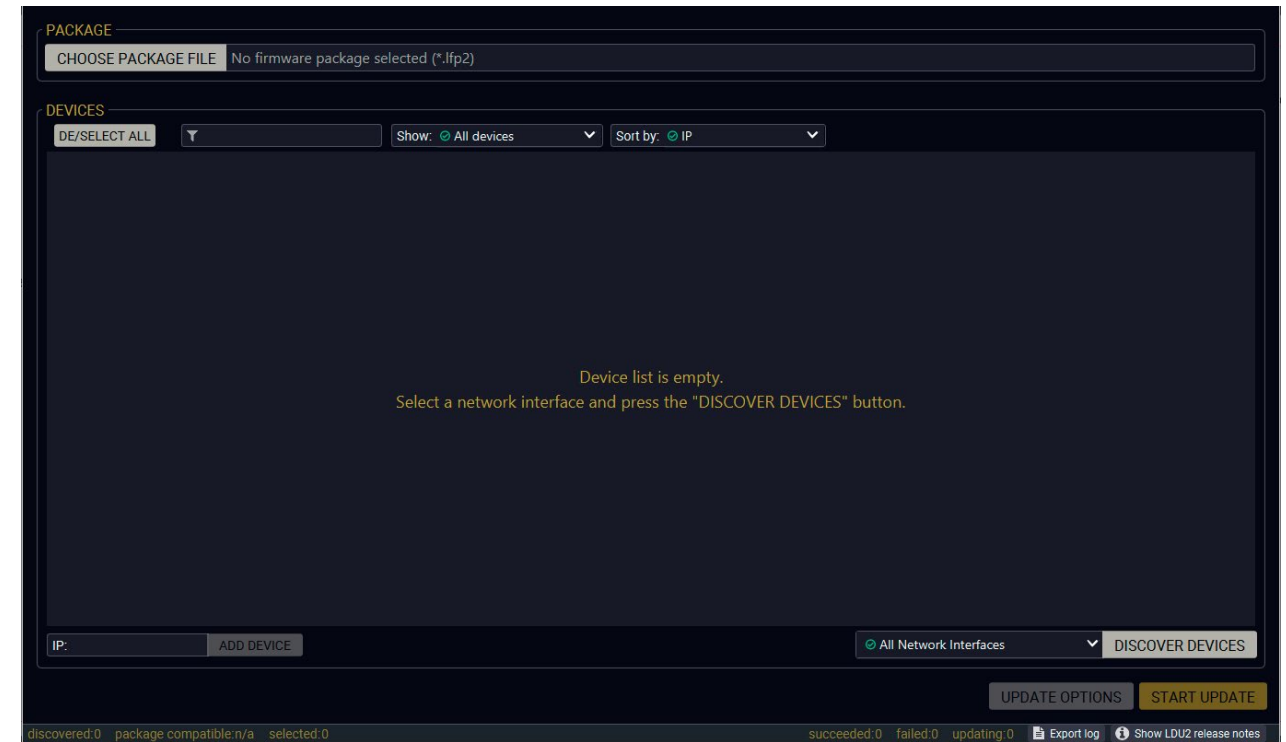

LDU2 welcome screen

If you start the software by double-clicking on the LFP2 file, the firmware will be loaded. Press the **Discover devices** button; all the devices will be listed that are compatible with the selected firmware pack.

INFO: If you press the **Choose package file** button, the release notes of the LFP2 file will be displayed in the right panel; see the [Step 1. Select the Firmware Package](#) section.

Device List

When the discovery has completed, the devices available on the network are listed in the application.

The screenshot shows a software interface for managing devices. At the top, there is a 'PACKAGE' section with a dropdown menu showing 'No firmware package selected (*.Ifp2)'. Below this is the 'DEVICES' section, which contains a table of discovered devices. The table has columns for ID, device name, IP address, package version, and hardware version. There are also icons for each device, such as a star for favorites and a wrench for service mode. At the bottom of the interface, there is an input field for an IP address (172.24.5.12) and an 'ADD DEVICE' button. There are also buttons for 'UPDATE OPTIONS' and 'START UPDATE'.





ID	Device Name	IP	Package	HW
1.	MX2M-FR24R MX2M-FR24R	172.24.5.12	v1.1.0b1	V11_AAAX
2.	MX2-16x16-HDMI20-Audio MX2-16x16-HDMI20-Audio	192.168.4.61	v1.5.0b1	V10_BAA0
3.	MX2-48x48-HDMI MX2-48x48-HDMI	192.168.4.83		
4.	MMX4x2-HDMI MMX4x2-HDMI	192.168.4.90	v0.0.0b0	V10_AAA0
5.	UCX-4x2-HC30 LW_UCX-4x2-HC30_00006874	192.168.4.118	v1.0.0b6	V20_AXAX

If the desired device is not discovered, you can add it by typing the IP address in the dedicated field and pressing the **Add device** button.

Devices may also be added manually by typing the IP address in the box near the bottom of the screen. From LDU2 version v2.16.1, manual addition of devices can also be done using the hostname.

ATTENTION: If the device cannot be added by the hostname, please use the IP address.

Legend of the Icons

-  **IP address editor** The IP address of the device can be changed in the pop-up window.
-  **Identify me** Clicking on the icon results in the front panel LEDs blinking for 10 seconds, which helps to identify the device physically.
-  **Favorite device** The device has been marked, thus the IP address is stored. When a device is connected with that IP address, the star will be highlighted in that line.
-  **Further information available** Device is unreachable. Change the IP address by pressing the **IP address editor** icon or use the front panel buttons (if available).
-  **Service mode** The device is in bootload mode. Backup and restore cannot be performed in this case.

9.3. The Updating Steps

ATTENTION: While the firmware is being updated, the normal operation mode is suspended, as the device is switched to bootload mode. Signal processing is not performed. Do not interrupt the firmware update. If any problem occurs, reboot the unit and restart the process.

Keeping the Configuration Settings

By default, device configuration settings are restored when firmware update is finished. If factory reset has been chosen in the parameters window, all device settings will be erased. In the case of factory reset, you can save the settings of the device in the Lightware Device Controller software and restore it later.

The following flow chart demonstrates how this function works in the background.

Step 1. Create a backup

The current configuration of the device is being saved into a configuration backup file on your computer.

Step 2. Start the Update

The device reboots and starts in bootload mode (firmware update mode).

Step 3. Update

The CPU firmware is changed to the new one.

Step 4. Factory reset

All configuration settings are restored to the factory default values.

Step 5. Conversion / Restore

The firmware package checks the backup data before the restoration procedure, and if it is necessary, a conversion is applied to avoid incompatibility problems between the firmware versions. All configuration settings are restored to the device after the conversion.

If the factory default option is selected in the Parameters window, the conversion / restore procedure will not be performed!

Step 6. Finish

Once the firmware update procedure is finished, the device reboots and is ready to use.

9.4. Updating Via GUI

Step 1. Select the Firmware Package

Click on the **Choose Firmware Package** button and navigate to the location where the LFP2 file of the matrix frame is saved. When you click on the name of package, the preview of the release notes is displayed on the right side.

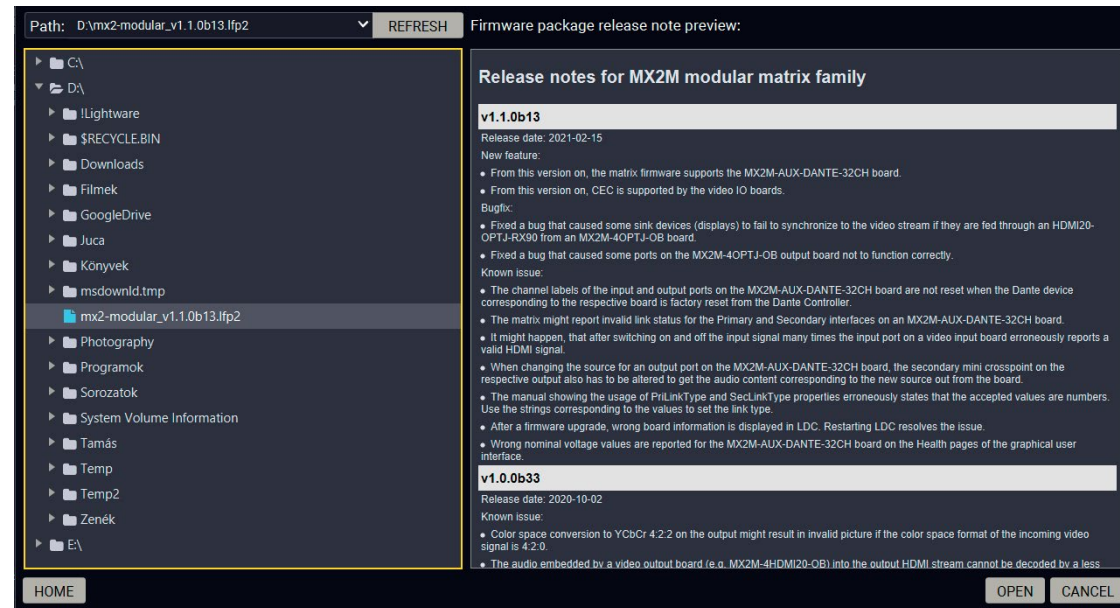

Firmware file browser and the release notes window

After the package file is loaded, the list is filtered to show compatible devices only. The current firmware version of the device is highlighted in orange if it is different from the version of the package loaded.

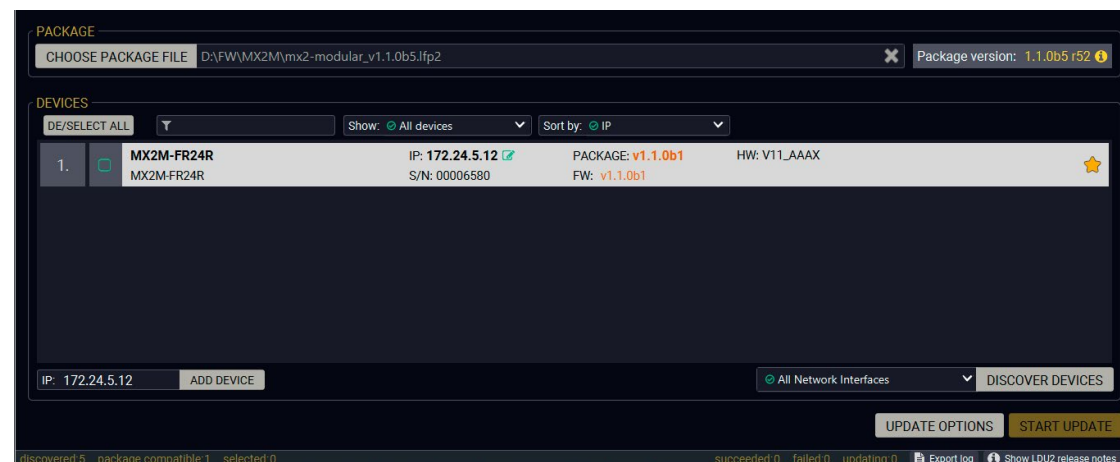

Filtered device list based on the selected firmware package

Step 2. Select the Desired Device for Updating

Pick the device for updating. The selected line will be highlighted in green.

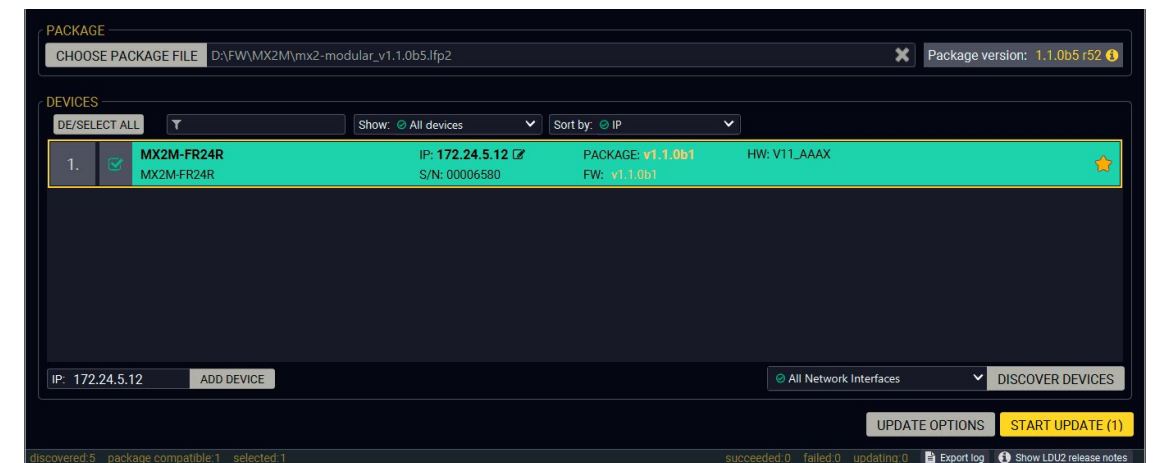

The remote unit is selected for updating

ATTENTION: It is essential to disconnect all fiber optical cables from the MX2M-4OPTJ-IB and MX2M-4OPTJ-OB boards. The update of the input/output boards might fail if the optical cables are connected during the update process. Should this be the case, unplugging the optical cables and restarting the matrix resolves the problem and the update gets finished successfully"

Step 3. Check the Update Parameters.

ATTENTION: The default settings in the Update options window should be fine for most cases. Please do not modify them if it is not necessary.

Click on the **Update options** button to configure the firmware update.

Configuration Backup and Restore

- **Restore device configuration settings:** the configuration settings of the endpoint devices will be restored after the firmware update.
- **Factory reset the device:** if it is checked, all user settings and parameters will be cleared and the factory default settings will be applied to the device when the update is done. See the whole list of factory default settings of the endpoint device in the [Factory Default Settings](#) section.
- **Backup folder:** Set the path of the device configuration backup file, which is created automatically. The default path is `USER_HOME/.ldu2/backup`.

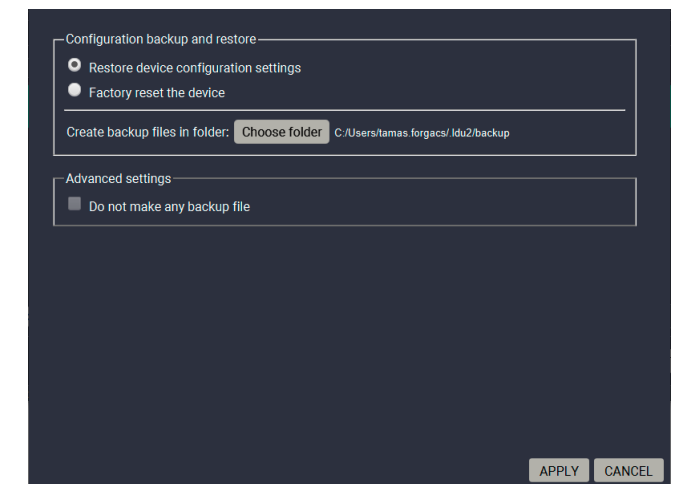

Advanced Settings

- **Do not make any backup file:** if it is checked, the configuration of the matrix switcher will not be restored after the firmware update.

Once the parameters are set, click on the **Apply** button to save the settings.

Step 4. Start the Update and Wait until It is Finished.

Click on the **Start Update** button to start the procedure.

The status is shown in percent in the right side of the device line and the status of all of the procedures is shown in the lower light green progress bar.

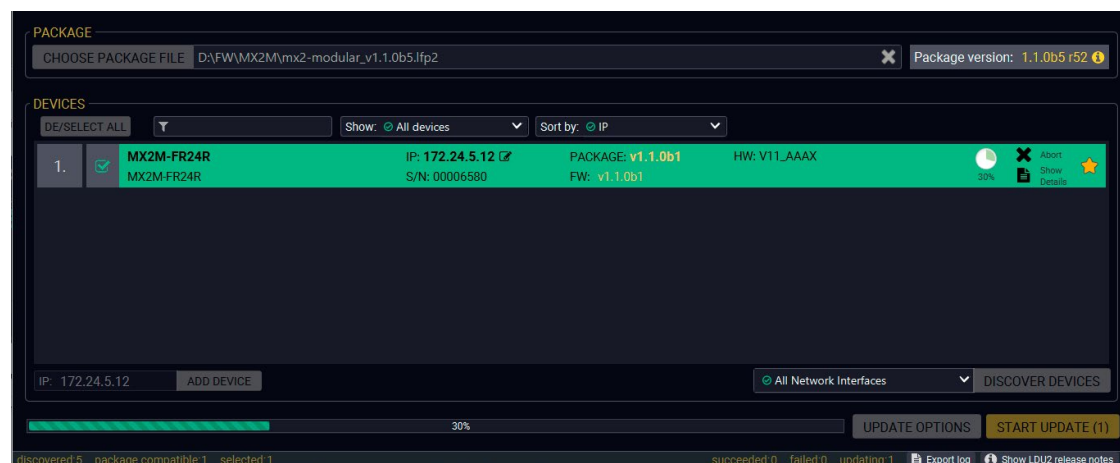

Firmware update is in progress

INFO: The device might reboot several times during the firmware update procedure.

Step 5. Wait until the Unit Reboots with the New Firmware.

Once the firmware update procedure is completed, the unit reboots with the new firmware.

9.5. Command Line Interface (CLI)

DIFFERENCE: The Command Line Interface is available from **LDU2 v2.9.0b9**.

The CLI of the LDU2 software is a simple tool for creating scriptable device updates without the need for human interactions. It allows batch updating with the same features that are available in case of GUI usage.

9.5.1. How to Run

Running under Windows® OS

The installer of LDU2 puts the following file into the installation folder:

LightwareDeviceUpdaterV2_CLI.cmd

CLI is available via this file, the exe is not suitable for that purpose. Open a command line window to execute or test the features directly.

- Step 1.** Open an Explorer window where the cmd file is located, the default is:
c:\Program Files (x86)\Lightware\Lightware Device Updater V2\LightwareDeviceUpdaterV2_CLI.cmd.
- Step 2.** Click on the address line (highlighted with blue in the picture), type **cmd.exe** and press enter. The command interpreter window of Windows is opened at the path of the LDU2 install folder.

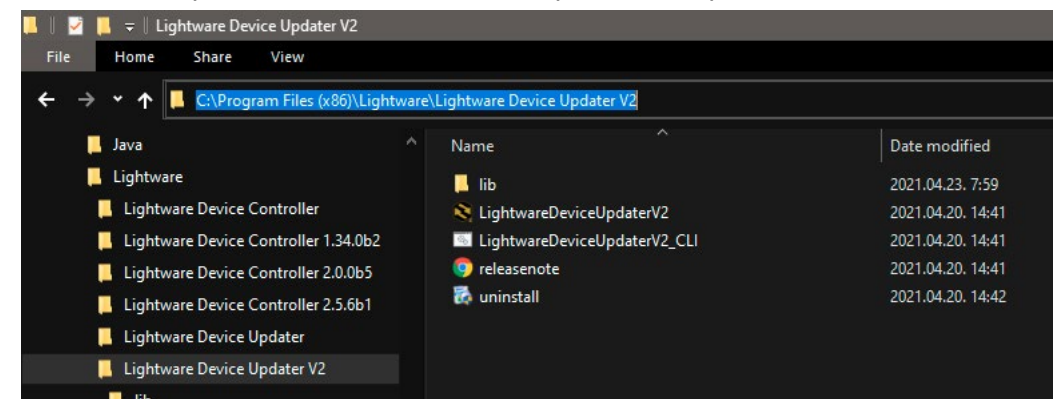

- Step 3.** Now you can use the LightwareDeviceUpdaterV2_CLI.cmd file with the commands and options, which are described in the coming sections:

Running under Linux

The Command Line Interface under Linux Operating Systems can be run by the following:

LightwareDeviceUpdaterV2.sh.

Running an update:

```
bash LightwareDeviceUpdaterV2.sh update --ip 192.168.0.85 --package ~/Downloads/mx2-modular_v1.2.0b6.lfp2
```

The commands and options are the same under Windows® and Linux, too. The following sections contain examples with **LightwareDeviceUpdaterV2_CLI.cmd**.

9.5.2. How to Use

Command Structure

The commands can be run over CLI in the following way:

LightwareDeviceUpdaterV2_CLI.cmd [command] [options]

[Command]: a certain command described in the coming sections; only one command can be run at a time.

[Options]: mandatory and/or optional parameters of the command, if any. Optional parameters have a default value, which can be found at each affected command. You only have to define the parameter if you want to apply a different value. The **order of the options** is arbitrary.

Important Notes

- CLI is **case-sensitive** (including commands, options and other parameters).
- There is **no limit** regarding the number of the devices to update. At most, 20 devices are updated simultaneously, when one of them is finished, the next (21st) will be started automatically.
- If an update is failed, the IP address of the affected device(s) are listed at the end.

9.6. CLI Commands

INFO: The commands and options described in the following sections are the same under Windows® and Linux, too. The examples contain **LightwareDeviceUpdaterV2_CLI.cmd**.

About the Examples

- Sent command is in **blue**, response is in **grey**.
- If the response in practice is **longer than listed** in the example, this symbol can be seen: [...].

9.6.1. Help

The defined commands and options can be listed by the **help** command.

Command

LightwareDeviceUpdaterV2_CLI.cmd help

Example

```
C:\Program Files (x86)\Lightware\Lightware Device Updater V2>LightwareDeviceUpdaterV2_CLI.cmd
help

C:\Program Files (x86)\Lightware\Lightware Device Updater V2>lib\jre\bin\java.exe -jar lib\
ldu2.jar help
Command line usage:
  Win: LightwareDeviceUpdaterV2_CLI.cmd [command] [options]
  Linux: LightwareDeviceUpdaterV2.sh [command] [options]

Commands:
* help
* version
* update
* deviceInfo
```

```
* restore
* packageOptions
[...]
```

9.6.2. LDU2 Version

The response shows the version of the LDU2 and the version of the Script API (the Application Programming Interface that is used by the LDU2 and the script).

Command

LightwareDeviceUpdaterV2_CLI.cmd version

Example

```
C:\Program Files (x86)\Lightware\Lightware Device Updater V2>LightwareDeviceUpdaterV2_CLI.cmd
version

C:\Program Files (x86)\Lightware\Lightware Device Updater V2>lib\jre\bin\java.exe -jar lib\
ldu2.jar version
LDU2 version: 2.9.0b9
Script API version: 1.3.9
```

9.6.3. Checking For New LDU2 Version

The following command can be used to check if an update of LDU2 is available. This is just a request, since the CLI is not suitable for handling the complete installer of the software.

Command

LightwareDeviceUpdaterV2_CLI.cmd checkForUpdates

Example 1

```
C:\Program Files (x86)\Lightware\Lightware Device Updater V2>LightwareDeviceUpdaterV2_CLI.cmd
checkForUpdates

C:\Program Files (x86)\Lightware\Lightware Device Updater V2>lib\jre\bin\java.exe -jar lib\
ldu2.jar checkForUpdates
Current LDU2 version: 2.9.1b1
LDU2 is up-to-date
```

Example 2

```
C:\Program Files (x86)\Lightware\Lightware Device Updater V2>LightwareDeviceUpdaterV2_CLI.cmd
checkForUpdates

C:\Program Files (x86)\Lightware\Lightware Device Updater V2>lib\jre\bin\java.exe -jar lib\
ldu2.jar checkForUpdates
Current LDU2 version: 2.9.1b1
New version is available online: v2.9.2b2
Download URL: http://update.lightware.hu/ldu2/lwr/v2.9.2b2/install_LDU2_v2.9.2b2.exe
```

9.6.4. Device Info

The most important information about the selected device is displayed; see the example for more details.

Command

```
LightwareDeviceUpdaterV2_CLI.cmd deviceInfo [options]
```

Options

Option	Description	Required?
-i or --ip	List of IP addresses of devices to be updated	one of them is mandatory
-n or --hostName	List of hostnames of devices to be updated	
-v or --packageVersion	Shows installed package version only	optional

Example 1

```
C:\Program Files (x86)\Lightware\Lightware Device Updater V2>LightwareDeviceUpdaterV2_CLI.cmd
deviceInfo --ip 192.168.0.85

C:\Program Files (x86)\Lightware\Lightware Device Updater V2>lib\jre\bin\java.exe -jar lib\
ldu2.jar deviceInfo --ip 192.168.0.85
Product name:   MX2M-FR24R
IP address:    192.168.0.85
Serial number: 00002263
MAC address:   a8:d2:36:ff:22:63
Part number:   91540065
Device label:  123
Package version: v1.1.0b6
CPU FW version: v1.1.0b3
HW version:    V12_KAA0
Operation mode: Application mode
```

Example 2

```
C:\Program Files (x86)\Lightware\Lightware Device Updater V2>LightwareDeviceUpdaterV2_CLI.cmd
deviceInfo --ip 192.168.0.85 --packageVersion

C:\Program Files (x86)\Lightware\Lightware Device Updater V2>lib\jre\bin\java.exe -jar lib\
ldu2.jar deviceInfo --ip 192.168.0.85 --packageVersion
v1.1.0b6
```

9.6.5. Update

This command can be used to update the firmware of the devices.

Command

```
LightwareDeviceUpdaterV2_CLI.cmd update [options]
```

Options

Option	Description	Required?
-p or --package	The path of the firmware package file	yes
-i or --ip	List of IP addresses of devices to be updated	one of them is mandatory
-n or --hostName	List of hostnames of devices to be updated	
-b or --backupFolder	Folder to create device configuration backup at. Default: USER_HOME/.ldu2/backup	optional
-f or --factoryDefault	Apply factory reset during device update. Default: false	optional
-r or --reportProgress	Report update progress in percent. Default: false	optional
Package-specific options	Certain LFP2 packages have features that can be applied at this command; see the Package Options section.	optional

ATTENTION: The configuration is restored automatically if the factory default option is not applied in the update command. In that case, there is no need to run the **restore** command after the update.

Example

```
C:\Program Files (x86)\Lightware\Lightware Device Updater V2>LightwareDeviceUpdaterV2_CLI.cmd
update --ip 192.168.0.85 --package C:\Firmwares\mx2-modular_v1.2.0b6.lfp2 --reportProgress

C:\Program Files (x86)\Lightware\Lightware Device Updater V2>lib\jre\bin\java.exe -jar lib\ldu2.
jar update --ip 192.168.0.85 --package C:\Firmwares\mx2-modular_v1.2.0b6.lfp2 --reportProgress
[2021-05-12 08:59:36.336] [ INFO] [          main] - Device IPs: [192.168.0.85]
[2021-05-12 08:59:39.409] [ INFO] [          main] - All the selected devices are accessible
over the network.
[2021-05-12 08:59:39.628] [ INFO] [          main] - All the selected devices are compatible
with the specified package.
[2021-05-12 08:59:40.025] [ INFO] [ 192.168.0.85] - Package version: 1.3.2b3
[2021-05-12 08:59:40.092] [ INFO] [ 192.168.0.85] - Login functionality is currently not
enabled.
[2021-05-12 08:59:40.129] [ INFO] [ 192.168.0.85] - Creating backup of device settings...
[2021-05-12 08:59:43.582] [ INFO] [ 192.168.0.85] - Backup HTTP enable properties
[2021-05-12 08:59:44.638] [ INFO] [ProgressReporter] - Progress: 2%
[2021-05-12 08:59:46.111] [ INFO] [ 192.168.0.85] - HTTP and HTTP post have got enabled on
port 80
[2021-05-12 08:59:46.319] [ INFO] [ 192.168.0.85] - No miniweb file is found on the device.
[2021-05-12 08:59:48.890] [ INFO] [ 192.168.0.85] - HTTP and HTTP post properties have got
restored on port 80
[2021-05-12 08:59:48.897] [ INFO] [ 192.168.0.85] - Switching device into bootload mode...
[2021-05-12 08:59:49.640] [ INFO] [ProgressReporter] - Progress: 5%
[...]
```

The lines containing "ProgressReporter" can be enabled optionally. If it is enabled, the current state is displayed every 5 seconds.

9.6.6. Restore

Restores device configuration from a backup file.

TIPS AND TRICKS: This command can be used for uploading a configuration to numerous devices (aka Configuration cloning by CLI).

Command

```
LightwareDeviceUpdaterV2_CLI.cmd restore [options]
```

Options

Option	Description	Required?
-i or --ip	List of IP addresses of devices to be updated	one of them is mandatory
-n or --hostName	List of hostnames of devices to be updated	
-b or --backupFile	The path of the configuration backup file	yes
-k or --keepOriginalIp	Do not override the network settings of the device with the ones in the backup file. It comes in handy when multiple devices' configuration is being restored from a single backup file. Default: false	optional

ATTENTION: The configuration is restored automatically if the factory default option is not applied in the **update** command. In that case, there is no need to run the **restore** command after the update.

Example

```
C:\Program Files (x86)\Lightware\Lightware Device Updater V2>LightwareDeviceUpdaterV2_CLI.cmd
restore --ip 192.168.0.85 --backupFile C:\mybackup.lw3 --keepOriginalIp

C:\Program Files (x86)\Lightware\Lightware Device Updater V2>lib\jre\bin\java.exe -jar lib\
ldu2.jar restore --ip 192.168.0.85 --backupFile C:\mybackup.lw3 --keepOriginalIp
[2021-05-12 10:49:36.412] [ INFO] [          main] - Executing configuration restore...
[2021-05-12 10:49:36.425] [ INFO] [          main] - Device IPs: [192.168.0.85]
```

INFO: The firmware package checks the backup data before the restoration procedure, and if it is necessary, a conversion is applied to avoid incompatibility problems between the firmware versions. In that case, two backup files are created: the original, and a new one with "_converted" suffix. Using the last one for restoring is recommended.

9.6.7. Package Options

Shows package-specific update options.

Command

```
LightwareDeviceUpdaterV2_CLI.cmd packageOptions [options]
```

Options

Option	Description	Required?
-p or --package	The path of the firmware package file	yes

Example

```
C:\Program Files (x86)\Lightware\Lightware Device Updater V2>LightwareDeviceUpdaterV2_CLI.cmd
packageOptions --package c:\Firmwares\mx2-modular_v1.2.0b6.lfp2

C:\Program Files (x86)\Lightware\Lightware Device Updater V2>lib\jre\bin\java.exe -jar lib\
ldu2.jar packageOptions --package c:\Firmwares\mx2-modular_v1.2.0b6.lfp2

Backup and restore options:
  --skipPresetsAtRestore : if true, device presets will not be restored. (Default: false)
  --uploadDefaultMiniWeb : if true and no custom miniweb is present on the device, the
default built-in miniweb will be uploaded to the device. (Default: false)

Test options:
  --test : if true, no update will be performed, communication with the device will be
tested. (Default: false)
```

Package option example can be seen in the following section.

9.6.8. Complex Example

The following options are applied:

- Firmware is updated
- Factory default settings are restored

```
C:\Program Files (x86)\Lightware\Lightware Device Updater V2>LightwareDeviceUpdaterV2_CLI.cmd
update --ip 192.168.0.85 --factoryDefault --package c:\Firmwares\mx2-modular_v1.2.0b6.lfp2

C:\Program Files (x86)\Lightware\Lightware Device Updater V2>lib\jre\bin\java.exe -jar lib\ldu2.
jar update --ip 192.168.0.85 --factoryDefault --package c:\Firmwares\mx2-standalone_v1.7.0b17.
lfp2
[2021-05-12 11:22:09.089] [ INFO] [          main] - Device IPs: [192.168.0.85]
[2021-05-12 11:22:12.947] [ INFO] [          main] - All the selected devices are accessible
over the network.
[2021-05-12 11:22:13.225] [ INFO] [          main] - All the selected devices are compatible
with the specified package.
[2021-05-12 11:22:13.777] [ INFO] [ 192.168.0.85] - Package version: 1.3.2b3
[2021-05-12 11:22:13.878] [ INFO] [ 192.168.0.85] - Login functionality is currently not
enabled.
[2021-05-12 11:22:13.896] [ INFO] [ 192.168.0.85] - Switching device into bootload mode...
[2021-05-12 11:22:34.519] [ INFO] [ 192.168.0.85] - Gathering UID information from device...
[2021-05-12 11:22:35.097] [ INFO] [ 192.168.0.85] - UID info - Device IP: 192.168.0.85
Product name: MX2-16x16-DH-8DPI-A-R Product part number: 91310068 Serial number: 00002263
Hardware version: V12_KAA0 MAC address: A8:D2:36:FF:22:63
[2021-05-12 11:22:35.589] [ INFO] [ 192.168.0.85] - Package version on device: 1.3.2b3 r44
[2021-05-12 11:22:35.626] [ INFO] [ 192.168.0.85] - Updating MX2 Standalone series
application fw part 1...
[2021-05-12 11:22:36.123] [ INFO] [ 192.168.0.85] - [mx2.bin.ER_IROM1]'s current version on
device: 1.3.1b1 r35
[2021-05-12 11:22:36.124] [ INFO] [ 192.168.0.85] - [mx2.bin.ER_IROM1]'s version in the
package: 1.3.1b1 r35
[2021-05-12 11:22:52.439] [ INFO] [ 192.168.0.85] - [tps_tx200.bin.ER_IROM1]'s firmware
version updated in FVS EEPROM.
[2021-05-12 11:22:52.442] [ INFO] [ 192.168.0.85] - Updating VS100TX fw...
[2021-05-12 11:22:52.920] [ INFO] [ 192.168.0.85] - [vs100_tx.bin]'s current version on
device: 1.1.0b0 r0
[2021-05-12 11:22:52.921] [ INFO] [ 192.168.0.85] - [vs100_tx.bin]'s version in the package:
1.1.0b0 r63
[2021-05-12 11:23:06.423] [ INFO] [ 192.168.0.85] - [vs100_tx.bin]'s firmware version
updated in FVS EEPROM.
[2021-05-12 11:23:06.425] [ INFO] [ 192.168.0.85] - Updating MX2 Standalone series
application fw part 2...
[2021-05-12 11:23:06.903] [ INFO] [ 192.168.0.85] - [mx2.bin.ER_IROM2]'s current version on
device: 1.3.1b1 r35
[2021-05-12 11:23:06.904] [ INFO] [ 192.168.0.85] - [mx2.bin.ER_IROM2]'s version in the
package: 1.2.0b6 r35
[2021-05-12 11:23:27.858] [ INFO] [ 192.168.0.85] - [mx2.bin.ER_IROM2]'s firmware version
updated in FVS EEPROM.
[2021-05-12 11:23:27.860] [ INFO] [ 192.168.0.85] - Updating PS171 FW...
[2021-05-12 11:23:28.338] [ INFO] [ 192.168.0.85] - [mx2_family_ps171.bin]'s current version
on device: 1.0.6b0 r0
[2021-05-12 11:23:28.340] [ INFO] [ 192.168.0.85] - [mx2_family_ps171.bin]'s version in the
package: 1.2.0b6 r522
[2021-05-12 11:23:44.810] [ INFO] [ 192.168.0.85] - [mx2_family_ps171.bin]'s firmware
version updated in FVS EEPROM.
```

```
[2021-05-12 11:23:51.412] [ INFO] [ 192.168.0.85] - Setting system information...
[2021-05-12 11:23:57.994] [ INFO] [ 192.168.0.85] - Starting application...
[2021-05-12 11:25:44.239] [ INFO] [ 192.168.0.85] - Done
```

```
All 1 update(s) finished successfully.
```

9.6.9. Exit Codes

There is a return value in all cases when a command run is finished. Currently, three codes are defined:

Code	Displayed text	Description
0	N/A	The update performed successfully
1	Update error (ErrorCode:1)	The error happened during the update
2	CLI error (ErrorCode:2)	The error happened before starting the update

The error line contains further information about the error.

Querying the Exit Code under Windows®

```
c:\Program Files (x86)\Lightware\Lightware Device Updater V2\echo %errorlevel%
0
```

Querying the Exit Code under Linux

```
echo $?
0
```

If this value is queried after the update and it is 0, the update performed successfully.

9.7. If the Update is not successful

- Restart the process and try the update again.
- If the device cannot be switched to bootload (firmware update) mode, you can do that manually as written in the User manual of the device. Please note that backup and restore cannot be performed in this case.
- If the backup cannot be created for some reason, you will get a message whether to continue the process without backup or stop the update. A root cause can be that the desired device is already in bootload (firmware update) mode, thus the normal operation mode is suspended and backup cannot be made.
- If an update is not successful, the **Export log** button becomes red. If you press the button, you can download the log file as a ZIP package, which can be sent to Lightware Support if needed. The log files contain useful information about the circumstances to find the root cause. *#bootload*

10

Troubleshooting





Usually, if the system seems not to transmit the signal as expected, the best strategy for troubleshooting is to check signal integrity through the whole signal chain starting from source side and moving forward to destination end.

















- ▶ Use Cases 130
- ▶ How to Speed Up the Troubleshooting Process 131



















10.1. Use Cases









At first, check front panel LEDs and take the necessary steps according to their states. For more information about status LEDs of the matrix frame and the I/O boards, refer to the [Product Overview](#) chapter.

Legend

-  Link to the section of connections/cabling.
-  Link to the section of front panel operation.
-  Link to the section of the built-in web page.
-  Link to the section of LW3 protocol commands.

Symptom	Root cause	Action	Refer to
Video signal			
No picture on the video output	Device or devices are not powered properly	Check the matrix and the other devices if they are properly powered; try to unplug and reconnect them.	 4.4.1
	Cable connection problem	Cables must fit very well, check all the AV connectors.	 4.4
	Optical cable became contaminated	Use special fiber optical cable cleaning equipment to clean it carefully.	
	No incoming signal	Check the cable connections on the input ports.	 4.4
	Not the proper video stream is the active one	Check which video stream is switched to the current output.	 3.1.2  7.4.1  8.6.1
	Input port is muted	Check the mute state of input port and unmute it.	 7.5  8.6.7
	Output port is muted	Check the mute state of output port and unmute it.	 7.5  8.6.11
	Display is not able to receive the video format	Check the emulated EDID; select another (e.g. emulate the EDID of the display on the input port).	 3.2.5  7.8  8.16
	HDCP is disabled	Enable HDCP on the input and output port.	 7.5  8.8.1  8.9.9  8.11.4

Symptom	Root cause	Action	Refer to
Not the desired picture displayed on the video output	Video output is set to test pattern (no sync screen), as there is no picture on video source	Check video settings of the source.	
Colors of the video are incorrect	Incorrect color space setting is active	Check the color space settings of the output port	 7.5.2
			 8.9.5
Audio signal			
No audio is present on output	Source audio volume is low or muted	Check the audio settings of the source.	
	The incoming audio signal is unsupported	Query the status of the audio output port and select a supported signal source	 7.6.2  7.6.4
	The analog audio output port is muted	Check the analog audio output port properties	 7.6.4  8.7.12
	Volume of the analog audio port is set low	Check the analog audio input/output port properties	 7.6.3  7.6.4  8.12.3
	Audio output is undefined	Use the Mapping channels for audio layer to the output tool defining the two audio channel to be transmitted.	 7.6.2  7.6.4
HDMI output signal contains no audio	DVI EDID is emulated	Check the EDID and select and HDMI EDID to emulate (the setting is available in the transmitter side).	 3.2.5  7.8  8.16
Not the desired audio can be heard on the output	Audio stream is switched to another output	Check which audio stream is switched to the current output.	 7.4.2
			 8.7.1
	Audio source setting is incorrect	Check the audio source setting on the digital audio input	 7.6.2  8.11.5

Symptom	Root cause	Action	Refer to
Network			
No LAN connection can be established	Incorrect IP address is set (fix IP)	Use dynamic IP address by enabling DHCP option.	 3.2.2  7.9.2  8.18
		Restore the factory default settings (with DHCP).	 3.2.2  7.9.4  8.4.13
	IP address conflict	Check the IP address of the other devices, too.	
Miscellaneous			
Front panel button is out of operation	The button or front panel LCD menu is locked	Disable control lock.	 3.1.6  8.4.8

10.2. How to Speed Up the Troubleshooting Process

Lightware's technical support team is always working hard to provide the fastest support possible. Our team's response time is one of the best in the industry, and in the toughest of cases we can directly consult with the hardware or software engineer who designed the product to get the information from the most reliable source.

However, the troubleshooting process can be even faster... with your help.

There are certain pieces of information that push us in the right direction to find the root cause of the problem. If we receive most of this information in the first e-mail, or it is gathered at the time when you call us, then there is a pretty high chance that we will be able to respond with the final solution right away.

This information is the following:

- Schematic (a pdf version is preferred, but a hand drawing is sufficient).
- Serial number(s) of the device(s) (it is either printed somewhere on the box or you can query it in the Device Controller software or on the built-in website).
- Firmware versions of the devices (please note that there may be multiple CPUs or controllers in the device and we need to know all of their firmware versions a screenshot is the best option).
- Cable lengths and types.
- Patch panels, gender changers or anything else in the signal path that can affect the transmission.
- Signal type (resolution, refresh rate, color space, deep color).
- Emulated EDID(s) (please save them as a file and send it to us).
- Actions to take in order to re-create the problem (if we cannot reproduce the problem, it is hard for us to find the cause).
- Photo or video about the problem (for example: "image noise" can mean many different things, it's better if we see it too).
- Error logs from the Device Controller software.
- In the case of an Event Manager issue, the event file and/or backup file from the Device Controller software.

The more of the information above you can give us, the better. Please send this information to the Lightware Support Team (support@lightware.com) to speed up the troubleshooting process.

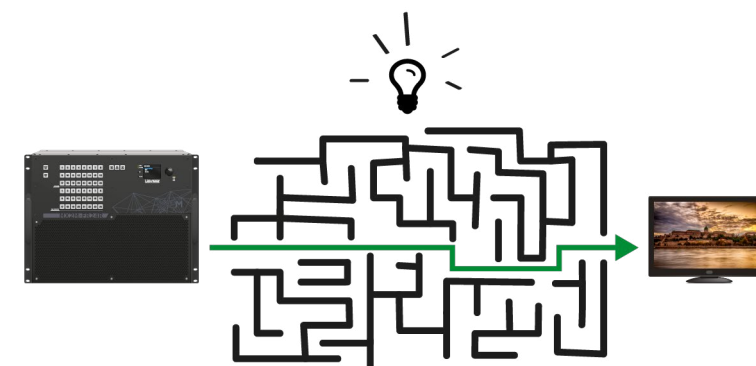

11

Technologies

The following sections contain descriptions and useful technical information on how the devices work in the background. The content is based on experiences and cases we met in the practice. These sections help to understand features and technical standards like the following:

- ▶ EDID Management 133
- ▶ HDCP Management 134
- ▶ Pixel Accurate Reclocking 136

11.1. EDID Management

11.1.1. Understanding the EDID

The Extended Display Identification Data (EDID) is the passport of display devices (monitors, TV sets, projectors). It contains information about the capabilities of the display, such as supported resolutions, refresh rates (these are called Detailed Timings), the type and manufacturer of the display device, etc.

After connecting a source to a display (DVI, HDMI, DP), the source reads out the EDID to determine the resolution and refresh rate of the image to be transmitted.

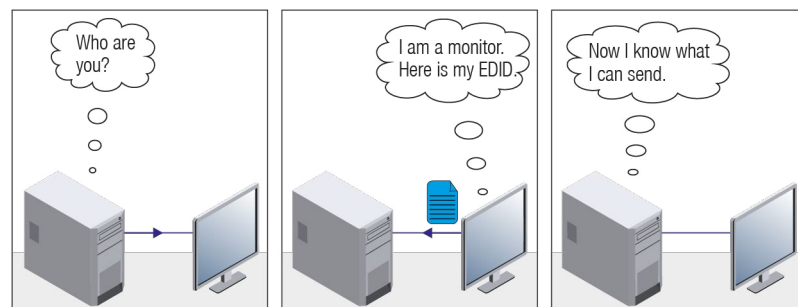

EDID communication

Most DVI computer displays have a 128-byte-long EDID structure. However, Digital Televisions and HDMI capable displays may have another 128 bytes, which is called E-EDID and is defined by CEA (Consumer Electronics Association). This extension contains information about additional Detailed Timings, audio capabilities, speaker allocation and HDMI capabilities. It is important to know that all HDMI capable devices must have CEA extension, but not all devices with CEA extension are HDMI capable.

Common Problems Related to EDID

- Problem:** “My system consists of the following: a computer, a Lightware device, a WUXGA (1920x1200) LCD monitor, and an SXGA (1280x1024) projector. I would like to see the same image on the monitor and the projector. What EDID should I choose on the Lightware device?”
- Solution:** If you want to see the image on both displays, you need to select the resolution of the smaller display (in this case SXGA), otherwise the smaller display may not show the higher resolution image.
- Problem:** “I have changed to a different EDID on an input port of the Lightware device to have a different resolution, but nothing happens.”
- Solution:** Some graphics cards and video sources read out the EDID only after power-up, and later they do not sense that the EDID has been changed. You need to restart your source to make it read out the EDID again.

11.1.2. Advanced EDID Management

Each DVI sink (e.g. monitors, projectors, plasma displays, etc...) must support the EDID data structure. Source BIOS and operating systems are likely to query the sink using DDC2B protocol to determine what pixel formats and interface are supported. DVI standard uses EDID data structure to identify the monitor type and capabilities. Most DVI sources (VGA cards, set top boxes, etc.) will output DVI signal after accepting the connected sink's EDID information. In the case of EDID readout failure or missing EDID, the source will not output DVI video signal.

Lightware devices provide the Advanced EDID Management function that helps system integration. The built-in EDID Router can store and emulate factory pre-programmed- and User programmable EDIDs. The EDID of the attached monitors or projectors for each output are stored in a non-volatile memory. This way the EDID of a monitor is available when the monitor is unplugged or switched off.

Any EDID can be emulated on any input. An emulated EDID can be copied from the EDID router's memory (static EDID emulation), or from the last attached monitor's memory (dynamic EDID emulation). For example, the Lightware device can be set up to emulate a sink device, which is connected to one of the outputs. In this case, the EDID automatically changes if the monitor is replaced with another display device (as long as it has a valid EDID).

EDID is independently programmable for all inputs without affecting each other. All inputs have their own EDID circuit.

INFO: The user is not required to disconnect the video cable to change an EDID as opposed to other manufacturer's products. EDID can be changed even if a source is connected to the input and powered ON.

INFO: When EDID has been changed, the router toggles the HOTPLUG signal for 2 seconds. Some sources do not sense this signal. In such cases, the source device must be restarted or powered OFF and ON again.

11.2. HDCP Management

Lightware Visual Engineering is a legal HDCP adopter. Several functions have been developed that help solve HDCP related problems. Complex AV systems often have both HDCP and non-HDCP components. The matrix allows transmitting HDCP encrypted and unencrypted signals. The devices will be still HDCP compliant, as they will never output an encrypted signal to a non-HDCP compliant display device. If an encrypted signal is switched to a non-compliant output, a red screen alert or muted screen will appear.

11.2.1. Protected and Unprotected Content

Many video sources send HDCP protected signal if they detect that the sink is HDCP capable – even if the content is not copyrighted. This can cause trouble if an HDCP capable device is connected between the source and the display. In this case, the content cannot be viewed on non-HDCP capable displays and interfaces like event controllers. Rental and staging technicians often complain about certain laptops, which are always sending HDCP encrypted signals if the receiver device (display, matrix router, etc.) reports HDCP compliancy. Even through, HDCP encryption is not required all the time (e.g. computer desktop image), certain laptops still do that.

To avoid unnecessary HDCP encryption, Lightware introduced the HDCP enabling/disabling function: the HDCP capability can be disabled in the Lightware device. If HDCP is disabled, the connected source will detect that the sink is not HDCP capable, and turn off authentication.

11.2.2. Disable Unnecessary Encryption

HDCP Compliant Sink

All the devices are HDCP-compliant, no manual setting is required, both protected and unprotected contents are transmitted and displayed on the sink.



Not HDCP-compliant Sink 1.

Not-HDCP compliant sink is connected to the matrix. Some sources (e.g. computers) always send HDCP encrypted signals if the receiver device reports HDCP compliancy, however, HDCP encryption is not required all the time (e.g. computer desktop image). If HDCP is enabled in the matrix, the image will not be displayed on the sink.



Setting the HDCP parameter to Auto on the output port and disable HDCP on the input port, the transmitted signal will not be encrypted if the content is not protected. Thus, non-HDCP compliant sinks will display non-encrypted signal.

Not HDCP-compliant Sink 2.

The layout is the same as in the previous case: non-HDCP compliant display device is connected to the matrix but the source would send protected content with encryption. If HDCP is enabled on the input port of the matrix, the source will send encrypted signal.



The sink is not HDCP compliant, thus it will not display the video signal (but blank/red/muted/etc. screen). If HDCP is disabled on the input port of the matrix, the source will not send the signal. The solution is to replace the display device to an HDCP-capable one.

11.2.3. HDCP 2.3

HDCP 2.3 is the latest evolution of copy protection. It is designed to create a secure connection between a source and a display. The 2.x version of HDCP is not a continuation of HDCPv1, and is rather a completely different link protection. One of the main differences is the number of the allowed devices within a closed A/V system: HDCP 2.3 allows 32 devices (HDCP 1.4 allows 128 devices). A further limit is that up to four level is allowed, which means the protected signal can be transmitted over at most four repeater/matrix/switcher devices. HDCP content protection is activated only if an active video stream is transmitted from the source to the display. The encryption is not activated without a video signal.

HDCP 2.3 standard allows applying a previous version of HDCP (e.g. HDCP 1.4) between the source and the display if the source device allows it. According to the standard if the image content is protected with HDCP, the highest supported content protection level has to be applied. However, if the highest level of protection is not justified by the source content, the level may be decreased to avoid compatibility problems; this case is determined by the source.

HDCP 2.3 Source and HDCP 1.4 Sink

In this case the signal of an HDCP 2.3 compliant source is switched to an HDCP 1.4 compliant sink device. The signal is encrypted with HDCP 2.3 on the input and encrypted with HDCP 1.4 on the output of the Lightware device. A lower level of encryption may be applied only if the source device/content allows it - according to the HDCP standard. In this case the HDCP setting on the input port has to be set to HDCP 1.4 and Depends on input on the output port.



HDCP 1.4 Source and HDCP 2.3 Sink

The example below is the reversal of the previous case. An HDCP 1.4 compliant source sends a signal with HDCP 1.4 encryption. The signal is switched to an HDCP 2.3 compliant sink device. In this case the outgoing signal has to be encrypted with the highest supported encryption level towards the sink, as the Lightware device and the sink are both HDCP 2.3 compliant. The HDCP 2.3 standard does not allow keeping the original HDCP 1.4 encryption level on the output.



What Kind of Signal Will be on the Output of the Lightware Device?

See the table below that summarizes the possible cases:

Incoming Signal	HDCP 1.4 Compatible Sink on the Output	HDCP 2.3. Compatible Sink on the Output
HDCP 1.4	HDCP 1.4	HDCP 2.3
HDCP 2.3 (convertable)*	HDCP 1.4	HDCP 2.3
HDCP 2.3 (not convertable)**	Red screen	HDCP 2.3

* Stream type 0: the video stream allows the conversation of the signal to apply a lower level of encryption.

** Stream type 1: the video stream does not allow the conversation of the signal.

11.3. Pixel Accurate Reclocking

Signal reclocking is an essential procedure in digital signal transmission. After passing the reclocking circuit, the signal becomes stable, jitter-free, and can be transmitted over more equipment like processors, or event controllers. Without reclocking, sparkles, noise, and jaggies appear on the image.

Lightware’s sophisticated Pixel Accurate Reclocking technology fixes more problems than general TMDS reclocking. It removes not only intra-pair skew, but inter-pair skew as well. The Pixel Accurate Reclocking circuit eliminates the following errors:

Intra-pair skew

Skew between the + and - wires within a differential wire pair (e.g. Data2- and Data2+). It’s caused by different wire lengths or slightly different wire construction (impedance mismatch) in the DVI cable. It results in jitter.

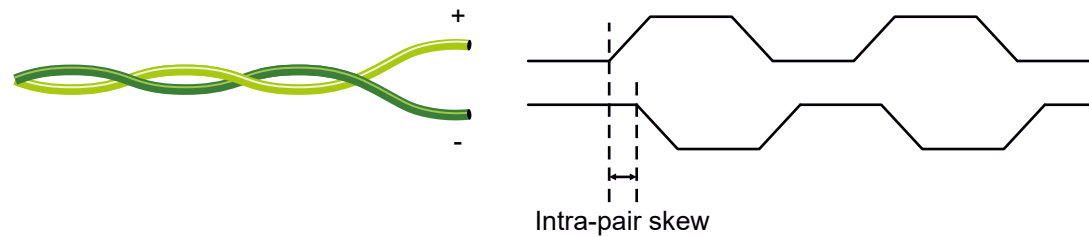

Inter-pair skew

Skew between two differential wire pairs in a cable. It is caused by different wire pair lengths or different number of twists in the DVI cable. Too much inter-pair skew results in color shift in the picture or sync loss.

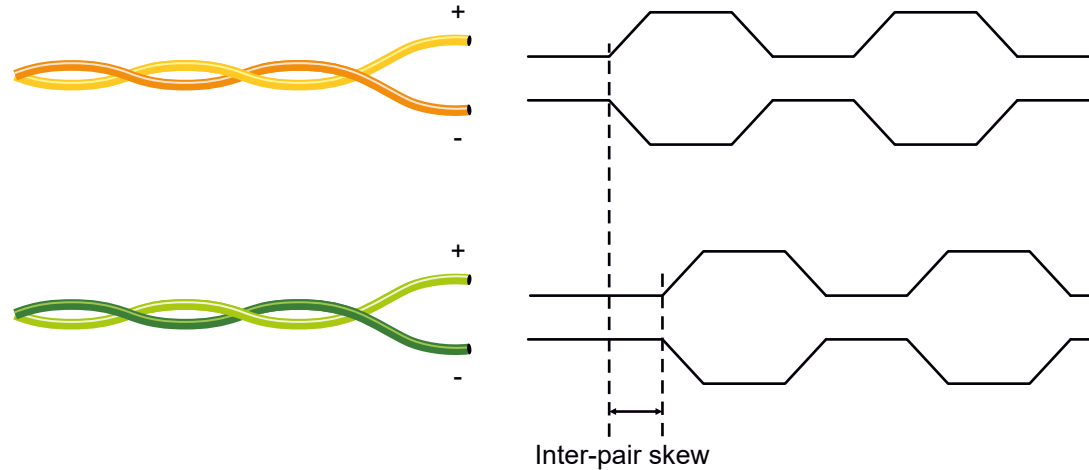

Jitter

Signal instability in the time domain. The time difference between two signal transitions should be a fixed value, but noise and other effects cause variations.

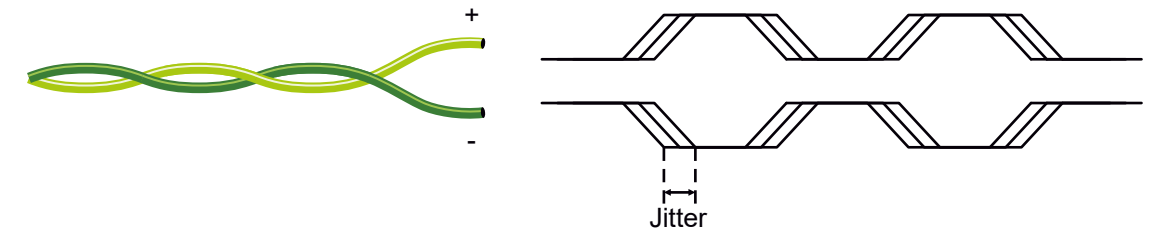

Noise

Electromagnetic interference between other electronic devices such as mobile phones, motors, etc. and the DVI cable are coupled onto the signal. Too much noise results in increased jitter.

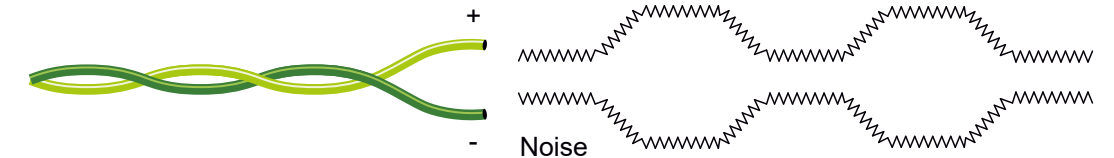

INFO: The colors of the wire pairs in the pictures are for illustration and do not represent the color of the actual wires inside the cable.

12

Appendix

Tables, drawings, guides, technical details and the hashtag keyword list as follows:

▶ Specification	138
▶ Switch Setup for Dante® Audio Signal Transmission	145
▶ Applied Ports (Network Settings)	145
▶ Factory Default Settings	146
▶ Input/Output Port Numbering	147
▶ Maximum Cable Distances	148
▶ Factory EDID List	149
▶ Cable Wiring Guide	151
▶ Mechanical Drawings	152
▶ Release Notes of the Firmware Packages	154
▶ Hashtag Keyword List	157
▶ Further Document Information	159
▶ Limited Warranty Statement	159

12.1. Specifications

INFO: Specifications are subject to change without notice.

12.1.1. MX2M-FR24R

General

Compliance	CE, UKCA
EMC (emission)	EN 55032:2015+A1:2020
EMC (immunity)	EN 55035:2017+A11:2020
RoHS	EN 63000:2018
Electrical safety	EN 62368-1:2020
Laser safety	EN 60825-1:2014+A11:2021
Warranty	3 years
Cooling	5x built-in cooling fans
Operating temperature	0°C to +50°C (+32°F to +122°F)
Storage temperature	-30°C to +80°C (-22°F to +176°F)
Operating humidity	10% to 90%, non-condensing

Power

Number of power drawer slots	2
Applicable power drawers	MX2M-PSU-500-F
	MX2M-PSU-1250-FP

Enclosure

Rack mountable	Yes
Material	1.5 mm steel
Rack size	8U high, 1 rack wide
Dimensions in mm	441W x 400D x 354.8H
Dimensions in inch	17.4W x 15.7D x 14H
Dimensions with rack ears and PSU drawers in mm	483W x 473D x 354.8H
Dimensions with rack ears and PSU drawers in inch	19W x 18.6D x 14H
Weight (frame only)	15.9 kg (35.05 lbs)
Weight (installed with two power supply units)	24.9 kg (54.89 lbs)

Control Ports

Ethernet Ports

Number of ports	3
-----------------	---

Connector type	Neutrik etherCON RJ45 female connector
Ethernet data rate	10/100/1000Base-T, full duplex with autodetect
Power over Ethernet (PoE)	Not supported

RS-232 Serial Port

Number of ports	1
Connector type	9-pole D-SUB female
Baud rates	Between 4800 and 115200 Baud
Data bits	8 or 9
Parity	None / Odd / Even
Stop bits	1 / 1.5 / 2

USB Port

Number of ports	1
Connector type	USB mini-B type
USB compliance	USB 2.0

12.1.2. MX2M-PSU-500-F

General

Compliance	CE, UKCA
EMC (emission)	EN 55032:2015+A1:2020
EMC (immunity)	EN 55035:2017+A11:2020
RoHS	EN 63000:2018
Electrical safety	EN 62368-1:2020
Warranty	3 years
Cooling	by cooling fan fitted in the frame
Operating temperature	0°C to +50°C (+32°F to +122°F)
Storage temperature	-40°C to +85°C (-40°F to +185°F)
Operating humidity	10% to 90%, non-condensing

Power Adaptor

Supported power source	100-240 V AC; 50/60 Hz
Input voltage range	90-264 VAC
Input frequency range	47-63 Hz
Input AC current (typ)	4.85 A
Rated output current	41.7 A @ 12 VDC

AC power connector	IEC C14 receptacle
Nominal power	500 W

Enclosure

Hot-swappable	Yes
Dimensions in mm	206W x 376D x 48H
Dimensions in inch	8.11W x 14.8D x 1.89H
Weight	3110 g (6.86 lbs)

12.1.3. MX2M-PSU-1250-FP**General**

Compliance	CE, UKCA
EMC (emission)	EN 55032:2015+A1:2020
EMC (immunity)	EN 55035:2017+A11:2020
RoHS	EN 63000:2018
Electrical safety	EN 62368-1:2020
Warranty	3 years
Cooling	by cooling fan fitted in the frame
Operating temperature	0°C to +50°C (+32°F to +122°F)
Storage temperature	-40°C to +85°C (-40°F to +185°F)
Operating humidity	10% to 90%, non-condensing

Power Adaptor

Supported power source	100-240 V AC; 50/60 Hz
Input voltage range	90-264 VAC
Input frequency range	47-63 Hz
Input AC current (typ)	12.35 A
Rated output current	41.7 A @ 12 VDC, 15.7A @ 48 VDC
AC power connector	IEC C14 receptacle
Nominal power	1250 W

Enclosure

Hot-swappable	Yes
Dimensions in mm	206W x 376D x 48H
Dimensions in inch	8.11W x 14.8D x 1.89H
Weight	4480 g (9.87 lbs)

12.1.4. MX2M-4HDMI20-IB**General**

Compliance	CE, UKCA
EMC (emission)	EN 55032:2015+A1:2020
EMC (immunity)	EN 55035:2017+A11:2020
RoHS	EN 63000:2018
Electrical safety	EN 62368-1:2020
Warranty	3 years
Cooling	passive
Operating temperature	0°C to +50°C (+32°F to +122°F)
Storage temperature	-40°C to +85°C (-40°F to +185°F)
Operating humidity	10% to 90%, non-condensing

Enclosure

Material	1.5 mm steel
Dimensions in mm	194.5W x 208.5D x 35.5H
Dimensions in inch	17.4W x 15.7D x 14H
Weight	276 g (0.6 lbs)

Video Inputs

Number of ports	4
Connector type	19-pole HDMI Type A receptacle
AV standard	DVI 1.0, HDMI 2.0
HDCP compliance	HDCP 1.4 and HDCP 2.3
Color space	RGB, YCbCr 4:4:4, YCbCr 4:2:2, YCbCr 4:2:0
Video delay	0 frame
Supported resolutions at 8 bits/color *	up to 4096x2160@60Hz (4:4:4) up to 3840x2160@60Hz (4:4:4)
Reclocking	Pixel Accurate Reclocking
3D support	Yes
Audio formats	8 channel PCM DTS, DTS-HD Master Audio 7.1, WMA Pro Dolby Digital, Dolby Digital Plus, Dolby TrueHD, Dolby Atmos, Dolby Vision
Input cable equalization	Yes, +12 dB fixed

* All standard VESA, CEA and other custom resolutions up to 600 MHz (HDMI 2.0) are supported. If the pixel

clock of the signal is above 340 MHz, horizontal resolution cannot exceed 4096 pixels.

12.1.5. MX2M-DH-4DP12-IB

General

Compliance	CE, UKCA
EMC (emission)	EN 55032:2015+A1:2020
EMC (immunity)	EN 55035:2017+A11:2020
RoHS	EN 63000:2018
Electrical safety	EN 62368-1:2020
Warranty	3 years
Cooling	passive
Operating temperature	0°C to +50°C (+32°F to +122°F)
Storage temperature	-40°C to +85°C (-40°F to +185°F)
Operating humidity	10% to 90%, non-condensing

Enclosure

Material	1.5 mm steel
Dimensions in mm	194.5W x 208.5D x 35.5H
Dimensions in inch	17.4W x 15.7D x 14H
Weight	288 g (0.63 lbs)

Video Inputs

Number of ports	4
Connector type	20-pole DisplayPort receptacle
AV standard	DP 1.2a
HDCP compliance	HDCP 1.4 and HDCP 2.3
Color space	RGB, YCbCr 4:4:4, YCbCr 4:2:2, YCbCr 4:2:0
Video delay	0 frame
Supported resolutions at 8 bits/color *	up to 4096x2160@60Hz (4:4:4) up to 3840x2160@60Hz (4:4:4)
Reclocking	Pixel Accurate Reclocking
3D support	Yes
Audio formats	8 channel PCM DTS, DTS-HD Master Audio 7.1, WMA Pro Dolby Digital, Dolby Digital Plus, Dolby TrueHD, Dolby Atmos, Dolby Vision

* All standard VESA, CEA and other custom resolutions up to 600 MHz (DP 1.2) are supported.

12.1.6. MX2M-40PTJ-IB

General

Compliance	CE, UKCA
EMC (emission)	EN 55032:2015+A1:2020
EMC (immunity)	EN 55035:2017+A11:2020
RoHS	EN 63000:2018
Electrical safety	EN 62368-1:2020
Laser safety	EN 60825-1:2014+A11:2021
Warranty	3 years
Cooling	2x built-in cooling fans
Operating temperature	0°C to +50°C (+32°F to +122°F)
Storage temperature	-40°C to +85°C (-40°F to +185°F)
Operating humidity	10% to 90%, non-condensing

Enclosure

Material	1.5 mm steel
Dimensions in mm	194.5W x 208.5D x 35.5H
Dimensions in inch	17.4W x 15.7D x 14H
Weight	340 g (0.74 lbs)

Video Inputs

AV standard	DVI 1.0, HDMI 2.0
HDCP compliance	HDCP 1.4 and HDCP 2.3
Color space	RGB, YCbCr 4:4:4, YCbCr 4:2:2, YCbCr 4:2:0
Video delay	0 frame
Supported resolutions at 8 bits/color *	up to 4096x2160@60Hz (4:4:4) up to 3840x2160@60Hz (4:4:4)
Reclocking	Pixel Accurate Reclocking
3D support	Yes
Audio formats	8 channel PCM DTS, DTS-HD Master Audio 7.1, WMA Pro Dolby Digital, Dolby Digital Plus, Dolby TrueHD, Dolby Atmos, Dolby Vision
Input cable equalization	Yes, +12 dB fixed

* All standard VESA, CEA and other custom resolutions up to 600 MHz (HDMI 2.0) are supported. If the pixel clock of the signal is above 340 MHz, horizontal resolution cannot exceed 4096 pixels.

Fiber Optical Ports

Number of ports	4
Connector type	SC simplex
Fiber type	50/125 SC multimode fiber
Laser wavelengths	High speed lane: 780, 800, 825, 850 nm Low speed lane: 910, 980 nm
Compliance	IEC/EN 60825-1:2014-05 Ed. 3.0; 21CFR Subchapter J Parts 1040.40 and 1040.11, except for deviations pursuant to Laser Notice No. 50 dated June 27, 2007
Transmitter output OMA (Optical Modulation Amplitude)	-6.25 dBm (worst case)
Receiver OMA (Optical Modulation Amplitude) sensitivity	-14.25 dBm (worst case)
Optical loss budget	8 dBm (worst case)

12.1.7. MX2M-4TPX-IB**General**

Compliance	CE, UKCA
EMC (emission)	EN 55032:2015+A1:2020
EMC (immunity)	EN 55035:2017+A11:2020
RoHS	EN 63000:2018
Electrical safety	EN 62368-1:2020
Warranty	3 years
Cooling	2x built-in cooling fans
Operating temperature	0°C to +50°C (+32°F to +122°F)
Storage temperature	-40°C to +85°C (-40°F to +185°F)
Operating humidity	10% to 90%, non-condensing

Enclosure

Material	1.5 mm steel
Dimensions in mm	194.5W x 208.5D x 35.5H
Dimensions in inch	17.4W x 15.7D x 1.4H
Weight	340 g (0.74 lbs)

Video Input

Number of ports	4
Connector type	RJ45 female connector
Power over Ethernet (PoE)	yes (IEEE 802.3af)
Compliance	AVX by SDVoE
HDCP compliance	HDCP 2.3
Transferred signals	Video, Audio, RS-232, Infrared, Ethernet, USB K+M
Color space	RGB, YCbCr
Video latency	0 frame (five lines / under 8ms)
Compression ratio	1.4 to 1 *
Supported resolutions at 8 bits/color **	up to 4096x2160@60Hz (4:4:4) up to 3840x2160@60Hz (4:4:4)
Audio formats	8 channel PCM DTS, DTS-HD Master Audio 7.1, WMA Pro Dolby Digital, Dolby Digital Plus, Dolby TrueHD, Dolby Atmos, Dolby Vision

* Compression is applied only if the AV signal is above HDMI 1.4 standard.

** All standard VESA, CEA and other custom resolutions up to 600 MHz (HDMI 2.0) are supported. If the pixel clock of the signal is above 340 MHz, horizontal resolution cannot exceed 4096 pixels.

12.1.8. MX2M-4HDMI20-OB**General**

Compliance	CE, UKCA
EMC (emission)	EN 55032:2015+A1:2020
EMC (immunity)	EN 55035:2017+A11:2020
RoHS	EN 63000:2018
Electrical safety	EN 62368-1:2020
Warranty	3 years
Cooling	passive
Operating temperature	0°C to +50°C (+32°F to +122°F)
Storage temperature	-40°C to +85°C (-40°F to +185°F)
Operating humidity	10% to 90%, non-condensing

Enclosure

Material	1.5 mm steel
Dimensions in mm	194.5W x 208.5D x 35.5H
Dimensions in inch	17.4W x 15.7D x 14H
Weight	276 g (0.6 lbs)

Video Outputs

A/V standard	DVI 1.0, HDMI 2.0
HDCP compliance	HDCP 1.4 and HDCP 2.3
Color space	RGB, YCbCr 4:4:4, YCbCr 4:2:2, YCbCr 4:2:0
Video delay	0 frame
Supported resolutions at 8 bits/color *	up to 4096x2160@60Hz (4:4:4) up to 3840x2160@60Hz (4:4:4)
Reclocking	Pixel Accurate Reclocking
3D support	Yes
Audio formats	8 channel PCM DTS, DTS-HD Master Audio 7.1, WMA Pro Dolby Digital, Dolby Digital Plus, Dolby TrueHD, Dolby Atmos, Dolby Vision
Input cable equalization	Yes, +12 dB fixed

* All standard VESA, CEA and other custom resolutions up to 600 MHz (HDMI 2.0) are supported. If the pixel clock of the signal is above 340 MHz, horizontal resolution cannot exceed 4096 pixels.

12.1.9. MX2M-4OPTJ-OB**General**

Compliance	CE, UKCA
EMC (emission)	EN 55032:2015+A1:2020
EMC (immunity)	EN 55035:2017+A11:2020
RoHS	EN 63000:2018
Electrical safety	EN 62368-1:2020
Laser safety	EN 60825-1:2014+A11:2021
Warranty	3 years
Cooling	2x built-in cooling fans
Operating temperature	0°C to +50°C (+32°F to +122°F)
Storage temperature	-40°C to +85°C (-40°F to +185°F)
Operating humidity	10% to 90%, non-condensing

Enclosure

Material	1.5 mm steel
Dimensions in mm	194.5W x 208.5D x 35.5H
Dimensions in inch	17.4W x 15.7D x 14H
Weight	340 g (0.74 lbs)

Video Outputs

AV standard	DVI 1.0, HDMI 2.0
HDCP compliance	HDCP 1.4 and HDCP 2.3
Color space	RGB, YCbCr 4:4:4, YCbCr 4:2:2, YCbCr 4:2:0
Video delay	0 frame
Supported resolutions at 8 bits/color *	up to 4096x2160@60Hz (4:4:4) up to 3840x2160@60Hz (4:4:4)
Reclocking	Pixel Accurate Reclocking
3D support	Yes
Audio formats	8 channel PCM DTS, DTS-HD Master Audio 7.1, WMA Pro Dolby Digital, Dolby Digital Plus, Dolby TrueHD, Dolby Atmos, Dolby Vision
Input cable equalization	Yes, +12 dB fixed

* All standard VESA, CEA and other custom resolutions up to 600 MHz (HDMI 2.0) are supported. If the pixel clock of the signal is above 340 MHz, horizontal resolution cannot exceed 4096 pixels.

Fiber Optical Ports

Number of ports	4
Connector type	SC simplex
Fiber type	50/125 SC multimode fiber
Laser wavelengths	High speed lane: 780, 800, 825, 850 nm Low speed lane: 910, 980 nm
Compliance	IEC/EN 60825-1:2014-05 Ed. 3.0; 21CFR Subchapter J Parts 1040.40 and 1040.11, except for deviations pursuant to Laser Notice No. 50 dated June 27, 2007
Transmitter output OMA (Optical Modulation Amplitude)	-6.25 dBm (worst case)
Receiver OMA sensitivity	-14.25 dBm (worst case)
Optical loss budget	8 dBm (worst case)

12.1.10. MX2M-4TPX-OB**General**

Compliance	CE, UKCA
EMC (emission)	EN 55032:2015+A1:2020
EMC (immunity)	EN 55035:2017+A11:2020
RoHS	EN 63000:2018
Electrical safety	EN 62368-1:2020
Warranty	3 years
Cooling	passive
Operating temperature	0°C to +50°C (+32°F to +122°F)
Storage temperature	-40°C to +85°C (-40°F to +185°F)
Operating humidity	10% to 90%, non-condensing

Enclosure

Material	1.5 mm steel
Dimensions in mm	194.5W x 208.5D x 35.5H
Dimensions in inch	17.4W x 15.7D x 14H
Weight	275 g (0.6 lbs)

Video Output

Number of ports	4
Connector type	RJ45 female connector
Power over Ethernet (PoE)	yes (IEEE 802.3af)
Compliance	AVX by SDVoE
HDCP compliance	HDCP 2.3
Transferred signals	Video, Audio, RS-232, Infrared, Ethernet, USB K+M
Color space	RGB, YCbCr
Video latency	0 frame (five lines / under 8ms)
Compression ratio	1.4 to 1 *
Supported resolutions at 8 bits/color **	up to 4096x2160@60Hz (4:4:4) up to 3840x2160@60Hz (4:4:4)
Audio formats	8 channel PCM DTS, DTS-HD Master Audio 7.1, WMA Pro Dolby Digital, Dolby Digital Plus, Dolby TrueHD, Dolby Atmos, Dolby Vision

* Compression is applied only if the AV signal is above HDMI 1.4 standard.

** All standard VESA, CEA and other custom resolutions up to 600 MHz (HDMI 2.0) are supported. If the pixel clock of the signal is above 340 MHz, horizontal resolution cannot exceed 4096 pixels.

12.1.11. MX2M-AUX-DANTE-32CH**General**

Compliance	CE, UKCA
EMC (emission)	EN 55032:2015+A1:2020
EMC (immunity)	EN 55035:2017+A11:2020
RoHS	EN 63000:2018
Electrical safety	EN 62368-1:2020
Warranty	3 years
Cooling	passive
Operating temperature	0°C to +50°C (+32°F to +122°F)
Storage temperature	-40°C to +85°C (-40°F to +185°F)
Operating humidity	10% to 90%, non-condensing

Enclosure

Material	1.5 mm steel
Dimensions in mm	194.5W x 208.5D x 35.5H
Dimensions in inch	17.4W x 15.7D x 14H
Weight	275 g (0.6 lbs)

Audio Ports

Number of ports	4
Connector type	RJ45 female connector
Audio formats	Dante® or AES67
Supported channels	2-channel stereo
Sampling rates	44.1, 48, 88.2, 96 kHz

12.1.12. MX2M-AUX-8AUDIO

General

Compliance	CE, UKCA
EMC (emission)	EN 55032:2015+A1:2020
EMC (immunity)	EN 55035:2017+A11:2020
RoHS	EN 63000:2018
Electrical safety	EN 62368-1:2020
Warranty	3 years
Cooling	passive
Operating temperature	0°C to +50°C (+32°F to +122°F)
Storage temperature	-40°F to +85°C (-40°F to +185°F)
Operating humidity	10% to 90%, non-condensing

Enclosure

Material	1.5 mm steel
Dimensions in mm	194.5W x 208.5D x 35.5H
Dimensions in inch	17.4W x 15.7D x 1.4H
Weight	275 g (0.6 lbs)

Audio Ports

Number of ports	8
Connector type	5-pole Phoenix connector
Port type	Configurable by jumper (Input / Output)

Analog Audio Inputs

Audio formats	2 channel PCM
Sampling frequency	48 kHz
Maximum input level	+4 dBu, 1.228 Vrms, 3.47 Vpp
Signal transmission	Balanced audio
Balance	-100 - 100 (0 = center)
Gain	-12 dB - 6 dB
Volume	-95 dB - 0 dB
Frequency response	20 Hz - 20 kHz
THD + Noise	-70 dB @ -1 dBFS
Interchannel isolation	83 dB

Analog Audio Outputs

Audio formats	2 channel PCM
Supported sampling frequency	44.1 kHz, 48 kHz, 88.2 kHz, 96 kHz
Volume	-78 dB - 0 dB
Balance	-100 - 100 (0 = center)
Nominal Differential Output Level @ 0 dB Gain	+4 dBu, 1.228 Vrms, 3.47 Vpp

12.2. Switch Setup for Dante® Audio Signal Transmission

You can configure the QoS settings to ensure good system performance in a busy network. QoS (Quality of Service) refers to technology for prioritizing the transfer of specific data. By configuring the QoS settings recommended by Dante on a network switch, you can prioritize the transfer of Dante clock synchronization data and audio data over background data traffic. This will ensure good system performance when you need to transfer non-Dante data over the same network. QoS is required when using Dante in networks that have 100Mbps devices and is optional in networks with Gigabit devices. We recommend that QoS be enabled in all Dante networks in order to ensure proper operation under all possible conditions.

The table below shows how Dante uses various Diffserv Code Points (DSCP) packet priority values: *

Priority	Usage	DSCP Label	Hex	Decimal	Binary
High	Time critical PTP events	CS7	0x38	56	111000
Medium	Audio, PTP	EF	0x2E	46	101110
Low	(reserved)	CS1	0x08	8	001000
None	Other traffic	BestEffort	0x00	0	000000

Green Ethernet in the Network

EEE (Energy Efficient Ethernet) is a technology that reduces switch power consumption during periods of low network traffic. It is also sometimes known as Green Ethernet and IEEE802.3az.

Although power management should be negotiated automatically in switches that support EEE, it is a relatively new technology, and some switches do not perform the negotiation properly. This may cause EEE to be enabled in Dante networks when it is not appropriate, resulting in poor synchronisation performance and occasional dropouts.

* source: <https://www.getdante.com/support/faq/>

12.3. Applied Ports (Network Settings)

The following ports are necessary to pass via a network switch/firewall for a proper working between the device and the softwares:

Purpose/function	Affected Lightware software	Protocol	Port nr.
Firmware update TFTP	LDU2	UDP	69
		UDP	49990
		UDP	49995
Device Discovery	LDC	UDP	224.0.0.251:5353
Remote IP	LDC	UDP	230.76.87.82:37421
LW3 command protocol	-	TCP	6107
HTTP port (built-in web server)	-	TCP	80

12.4. Factory Default Settings

Parameter	Setting/Value
General settings	
Display backlight	10
Jog dial rotary direction	Clockwise (CW down)
Control lock	Disabled
Output lock	Disabled
Network settings	
DHCP (dynamic IP address)	Enabled
LW3 control protocol port number	6107
HTTP port number	80
RS-232 port settings	
Configuration	115200 BAUD 8N1
AV crosspoint settings	
Audio crosspoint	I1 to all outputs
Video crosspoint	I1 to all outputs
Video input port settings MX2M-4HDMI20-IB / MX2M-4OPTJ-IB / MX2M-4TPX-IB	
HDCP authentication	Enabled
Maximum enabled HDCP version	HDCP 2.3
Color range	Auto
Hot plug detect	Auto
PoE enaled (only in case of TPX)	false
Video input port settings MX2M-DH-4DP12-IB	
HDCP authentication	Enabled
Maximum enabled HDCP version	HDCP 2.3
Input lane count capability	4
Maximum link rate availability	HBR2
DP power sending	Enabled
Color space conversion	Passthrough
Color range	Auto
Hot plug detect	Auto
No sync screen (test pattern) mode	Disabled

Parameter	Setting/Value
Video output port settings MX2M-4HDMI20-OB / MX2M-4OPTJ-OB / MX2M-4TPX-OB	
HDCP mode	Auto (depends on input)
Power 5V mode	On
Signal type	Auto
Color space	Passthrough
Color depth	8 bit per pixel
Audio source	HDMI
PoE enaled (only in case of TPX)	false
Audio port settings MX2M-AUX-8AUDIO	
Port configuration	Input
Dante® port settings MX2M-AUX-DANTE-32CH	
IP address mode - Primary interface	Unknown/query
IP address mode - Secondary interface	Unknown/query
Analog audio input port properties	
Volume	0.00 dB (100%)
Balance	0 (center)
Gain	0.00 dB
Analog audio output port properties	
Volume	0.00 dB (100%)
Balance	0 (center)

12.5. Input/Output Port Numbering

12.5.1. Video Input/Output Port Numbering

The following drawing describes the video port numbering of the MX2M-FR24R matrix frame.

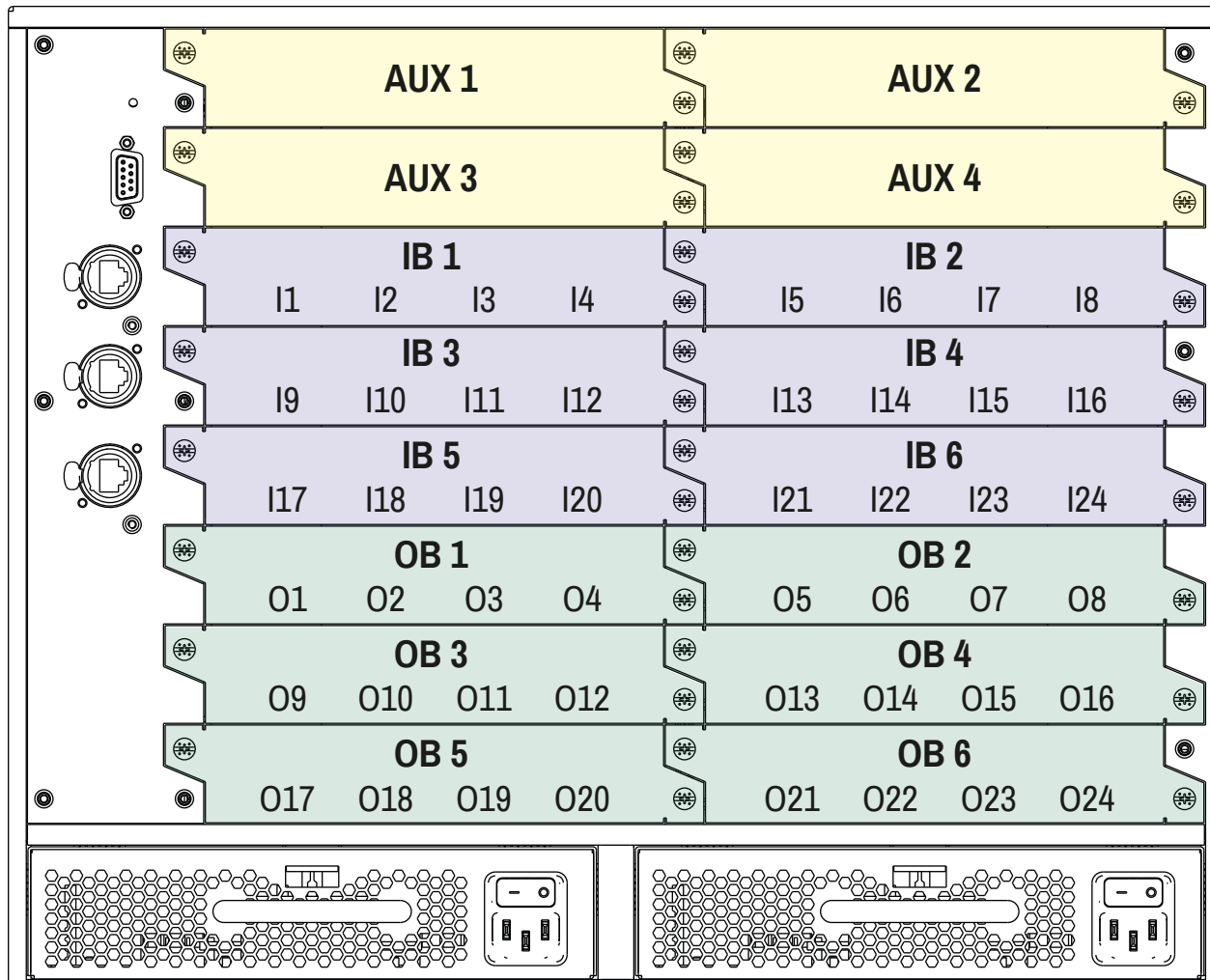

12.5.2. Audio Input Port Numbering

The following table shows the audio input numbering of the matrix. The audio port numbers are reserved and fixed for each I/O board slots because of the following reasons:

- The I/O board models are built with different number of ports;
- The boards can be installed to various board slots;
- The AUX boards can also be installed to the slots that are dedicated to IB and OB boards.

Input port numbering on IB boards	Input port numbering on AUX boards	Layout of the matrix		Input port numbering on IB boards	Input port numbering on AUX boards
		Left side	Right side		
-	I25-I40			-	I41-I56
-	I57-I72			-	I73-I88
I1-I4	I89-I104			I5-I8	I105-I120
I9-I12	I121-I136			I13-I16	I137-I152
I17-I20	I153-I168			I21-I24	I169-I184
-	I185-I200			-	I201-I216
-	I217-I232			-	I233-I248
-	I249-I264			-	I265-I280

12.5.3. Audio Output Port Numbering

The following table shows the audio output numbering of the matrix. The audio port numbers are reserved and fixed for each I/O board slots because of the following reasons:

- The I/O board models are built with different number of ports;
- The boards can be installed to various board slots;
- The AUX boards can also be installed to the slots that are dedicated to IB and OB boards.

Output port numbering on OB boards	Output port numbering on AUX boards	Layout of the matrix		Output port numbering on OB boards	Output port numbering on AUX boards
		Left side	Right side		
-	025-040			-	041-056
-	057-072			-	073-088
-	089-0104			-	0105-0120
-	0121-0136			-	0137-0152
-	0153-0168			-	0169-0184
01-04	0185-0200			05-08	0201-0216
09-012	0217-0232			013-016	0233-0248
017-020	0249-0264			021-024	0265-0280

12.6. Maximum Cable Distances

12.6.1. Fiber Optical Cable Distances

The following table shows the maximum allowed fiber optical cable distances.

Affected boards:

- MX2M-4OPTJ-IB
- MX2M-4OPTJ-OB

Resolution, Pixel clock rate	OM1	OM2	OM3	OM4
1280x720p60 Hz	800 m	1000 m	1200 m	1200 m
1920x1080p60 Hz	500 m	1000 m	1200 m	1200 m
3840x2160p30 Hz (4k30 4:4:4)	200 m	600 m	1200 m	1200 m
3840x2160p60 Hz (4k60 4:2:0)	200 m	600 m	1200 m	1200 m
3840x2160p60 Hz (4k60 4:4:4)	Not supported	300 m	600 m	600 m
4096x2160p60 Hz (DCI 4K60)	Not supported	300 m	600 m	600 m

12.6.2. CATx Cable Distances for Dante

The following table shows the maximum allowed CATx cable distances.

Affected board:

- MX2M-AUX-DANTE-32CH

Connection	CAT5e	CAT7e
Connection between the auxiliary board and the network switch	100 m	

12.6.3. CATx Cable Distances for TPX

The following table shows the maximum allowed CATx cable distances.

Affected board:

- MX2M-4TPX-IB
- MX2M-4TPX-OB

Resolution, Pixel clock rate	CAT6e		CAT7e	
	AWG27	AWG23	AWG26	AWG23
3840x2160p30 Hz (4k30 4:4:4)	85 m	100 m	90 m	100 m
3840x2160p60 Hz (4k60 4:4:4)	85 m	100 m	80 m	100 m

12.7. Factory EDID List

Mem	Resolution	Type	EDID features
F1	640 x 480p @ 60.00 Hz	D	DVI
F2	848 x 480p @ 60.00 Hz	D	DVI
F3	800 x 600p @ 60.32 Hz	D	DVI
F4	1024 x 768p @ 60.00 Hz	D	DVI
F5	1280 x 768p @ 50.00 Hz	D	DVI
F6	1280 x 768p @ 59.94 Hz	D	DVI
F7	1280 x 768p @ 75.00 Hz	D	DVI
F8	1360 x 768p @ 60.02 Hz	D	DVI
F9	1280 x 1024p @ 50.00 Hz	D	DVI
F10	1280 x 1024p @ 60.02 Hz	D	DVI
F11	1280 x 1024p @ 75.02 Hz	D	DVI
F12	1400 x 1050p @ 50.00 Hz	D	DVI
F13	1400 x 1050p @ 60.00 Hz	D	DVI
F14	1400 x 1050p @ 75.00 Hz	D	DVI
F15	1680 x 1050p @ 60.00 Hz	D	DVI
F16	1920 x 1080p @ 50.00 Hz	D	DVI
F17	1920 x 1080p @ 60.00 Hz	D	DVI
F18	2048 x 1080p @ 50.00 Hz	D	DVI
F19	2048 x 1080p @ 60.00 Hz	D	DVI
F20	1600 x 1200p @ 50.00 Hz	D	DVI
F21	1600 x 1200p @ 60.00 Hz	D	DVI
F22	1920 x 1200p @ 50.00 Hz	D	DVI
F23	1920 x 1200p @ 59.56 Hz	D	DVI
F24	2048 x 1200p @ 59.96 Hz	D	DVI
F29	1920 x 1080p @ 60.00 Hz	U	DVI
F30	1440 x 480i @ 60.05 Hz	H	HDMI; YUV444; YUV422; 2CH_AUD
F31	1440 x 576i @ 50.08 Hz	H	HDMI; YUV444; YUV422; 2CH_AUD
F32	640 x 480p @ 59.95 Hz	H	HDMI; YUV444; YUV422; 2CH_AUD
F33	720 x 480p @ 59.94 Hz	H	HDMI; YUV444; YUV422; 2CH_AUD
F34	720 x 576p @ 50.00 Hz	H	HDMI; YUV444; YUV422; 2CH_AUD

Mem	Resolution	Type	EDID features
F35	1280 x 720p @ 50.00 Hz	H	HDMI; YUV444; YUV422; 2CH_AUD
F36	1280 x 720p @ 60.00 Hz	H	HDMI; YUV444; YUV422; 2CH_AUD
F37	1920 x 1080i @ 50.04 Hz	H	HDMI; YUV444; YUV422; 2CH_AUD
F38	1920 x 1080i @ 50.00 Hz	H	HDMI; YUV444; YUV422; 2CH_AUD
F39	1920 x 1080i @ 60.05 Hz	H	HDMI; YUV444; YUV422; 2CH_AUD
F40	1920 x 1080i @ 60.05 Hz	H	HDMI; YUV444; YUV422; 2CH_AUD
F41	1920 x 1080p @ 24.00 Hz	H	HDMI; YUV444; YUV422; 2CH_AUD
F42	1920 x 1080p @ 25.00 Hz	H	HDMI; YUV444; YUV422; 2CH_AUD
F43	1920 x 1080p @ 30.00 Hz	H	HDMI; YUV444; YUV422; 2CH_AUD
F44	1920 x 1080p @ 50.00 Hz	H	HDMI; YUV444; YUV422; 2CH_AUD
F45	1920 x 1080p @ 59.94 Hz	H	HDMI; YUV444; YUV422; 2CH_AUD
F46	1920 x 1080p @ 60.00 Hz	H	HDMI; YUV444; YUV422; 2CH_AUD
F47	1920 x 1080p @ 60.00 Hz	U	HDMI; YUV444; YUV422; 2CH_AUD
F48	1920 x 1080p @ 60.00 Hz	U	HDMI; YUV444; YUV422; 8CH_AUD
F49	1920 x 1080p @ 60.00 Hz	U	HDMI; YUV444; YUV422; DC30; DC36; YUVDC; 8CH_AUD
F98	1280 x 720p @ 60.00 Hz	H	HDMI; YUV444; YUV422; 2CH_AUD; 3D
F99	1920 x 1080p @ 60.00 Hz	H	HDMI; YUV444; YUV422; 2CH_AUD; 3D
F100	1024 x 768p @ 60.00 Hz	H	HDMI; YUV444; YUV422; 2CH_AUD
F101	1280 x 1024p @ 50.00 Hz	H	HDMI; YUV444; YUV422; 2CH_AUD
F102	1280 x 1024p @ 60.02 Hz	H	HDMI; YUV444; YUV422; 2CH_AUD
F103	1280 x 1024p @ 75.02 Hz	H	HDMI; YUV444; YUV422; 2CH_AUD
F104	1600 x 1200p @ 50.00 Hz	H	HDMI; YUV444; YUV422; 2CH_AUD
F105	1600 x 1200p @ 60.00 Hz	H	HDMI; YUV444; YUV422; 2CH_AUD
F106	1920 x 1200p @ 59.56 Hz	H	HDMI; YUV444; YUV422; 2CH_AUD
F107	2560 x 1440p @ 59.95 Hz	H	HDMI; YUV444; YUV422; 2CH_AUD
F108	2560 x 1600p @ 59.86 Hz	H	HDMI; YUV444; YUV422; 2CH_AUD
F109	3840 x 2400p @ 24.00 Hz	H	HDMI; YUV444; YUV422; 2CH_AUD
F110	3840 x 2160p @ 24.00 Hz	H	HDMI; YUV444; YUV422; 2CH_AUD
F111	3840 x 2160p @ 25.00 Hz	H	HDMI; YUV444; YUV422; 2CH_AUD
F112	3840 x 2160p @ 30.00 Hz	H	HDMI; YUV444; YUV422; 2CH_AUD

Mem	Resolution	Type	EDID features
F118	3840 x 2160p @ 30.00 Hz	U	HDMI; YUV444; YUV422; 2CH_AUD
F119	3840 x 2160p @ 30.00 Hz	U	HDMI; YUV444; YUV422; 8CH_AUD
F120	3840 x 2160p @ 60.00 Hz	H	HDMI; YUV444; YUV422; YUV420; 2CH_AUD
F121	1440 x 1080p @ 59.91 Hz	H	HDMI; YUV444; YUV422; 2CH_AUD
F122	2560 x 2048p @ 59.98 Hz	H	HDMI; YUV444; YUV422; 2CH_AUD
F123	1280 x 800p @ 59.91 Hz	H	HDMI; YUV444; YUV422; 2CH_AUD
F124	1440 x 900p @ 59.90 Hz	H	HDMI; YUV444; YUV422; 2CH_AUD
F125	1366 x 768p @ 60.00 Hz	H	HDMI; YUV444; YUV422; 2CH_AUD
F126	1600 x 900p @ 59.98 Hz	H	HDMI; YUV444; YUV422; 2CH_AUD
F127	2048 x 1080p @ 60.00 Hz	H	HDMI; YUV444; YUV422; 2CH_AUD
F128	2560 x 1080p @ 60.00 Hz	H	HDMI; YUV444; YUV422; 2CH_AUD
F129	3440 x 1440p @ 24.99 Hz	H	HDMI; YUV444; YUV422; 2CH_AUD
F130	3440 x 1440p @ 29.99 Hz	H	HDMI; YUV444; YUV422; 2CH_AUD
F131	4096 x 2160p @ 25.00 Hz	H	HDMI; YUV444; YUV422; 2CH_AUD
F132	4096 x 2160p @ 30.00 Hz	H	HDMI; YUV444; YUV422; 2CH_AUD
F133	4096 x 2160p @ 60.00 Hz	4	HDMI; YUV444; YUV422; YUV420; 2CH_AUD
F134	3440 x 1440p @ 23.99 Hz	H	HDMI; YUV444; YUV422; 2CH_AUD
F135	4096 x 2160p @ 24.00 Hz	H	HDMI; YUV444; YUV422; 2CH_AUD
F136	3840 x 2400p @ 29.99 Hz	H	HDMI; YUV444; YUV422; 2CH_AUD
F137	3840 x 2160p @ 60.00 Hz	H	HDMI; HDMI2; YUV444; YUV422; 2CH_AUD
F138	3840 x 2160p @ 50.00 Hz	H	HDMI; HDMI2; YUV444; YUV422; 2CH_AUD
F139	3840 x 2160p @ 60.00 Hz	H	HDMI; HDMI2; YUV444; YUV422; YUV420; 2CH_AUD
F140	3840 x 2160p @ 60.00 Hz	H	HDMI; HDMI2; YUV444; YUV422; YUV420; 8CH_AUD
F141	4096 x 2160p @ 60.00 Hz	H	HDMI; HDMI2; YUV444; YUV422; 2CH_AUD
F142	4096 x 2160p @ 50.00 Hz	H	HDMI; HDMI2; YUV444; YUV422; 2CH_AUD
F143	4096 x 2160p @ 60.00 Hz	H	HDMI; HDMI2; YUV444; YUV422; YUV420; 2CH_AUD
F144	4096 x 2160p @ 60.00 Hz	H	HDMI; HDMI2; YUV444; YUV422; YUV420; 8CH_AUD
F145	2560 x 2048p @ 49.97 Hz	H	HDMI; YUV444; YUV422; 2CH_AUD
F146	3840 x 2160p @ 60.00 Hz	H	HDMI; HDMI2; YUV420; DC30; DC36; YUVDC; YUV420_DC30; YUV420_DC36; 2CH_AUD; HDR
F147	3840 x 2160p @ 60.00 Hz	H	HDMI; HDMI2; YUV444; YUV422; 2CH_AUD

Mem	Resolution	Type	EDID features
F148	3840 x 2160p @ 60.00 Hz	H	HDMI; HDMI2; YUV444; YUV422; 8CH_AUD
F150	5120 x 1440p @ 29.97 Hz	H	HDMI; HDMI2; 8CH_AUD; HDR; DiD
F151	5120 x 2160p @ 29.97 Hz	H	HDMI; HDMI2; 8CH_AUD; HDR; DiD
F152	5120 x 2880p @ 29.97 Hz	H	HDMI; HDMI2; 8CH_AUD; HDR; DiD
F153	7680 x 1080p @ 59.94 Hz	H	HDMI; HDMI2; 8CH_AUD; HDR; DiD

Legend**D:** DVI EDID**H:** HDMI EDID**U:** Universal EDID (supporting many common EDIDs)**4:2:0** :EDID with chroma color subsampling**4:4:4** :EDID without color subsampling**H2:** HDMI2.0-compatible EDID**HDR:** EDID with High Dynamic Range mode support**RB:** Reduced blanking interval**PCM:** With PCM audio support**ALL:** All type of audio support (within the HDMI standard)

Please note that minor changes in the factory EDID list may be applied in further firmware versions.

12.8. Cable Wiring Guide

Inputs and outputs of audio devices are symmetric or asymmetric. The main advantage of the symmetric lines is the better protection against the noise, therefore they are widely used in the professional audio industry. Symmetric audio is most often referred to as balanced audio, as opposed to asymmetric, which is referred to as unbalanced audio. Lighthouse products are usually built with 5-pole Phoenix connectors, so we would like to help users assemble their own audio cables. See the most common cases below.

ATTENTION: Symmetric and asymmetric lines can be linked with passive accessories (e.g. special cables), but in this case half of the line level is lost.

ATTENTION: There are numerous types of regularly used connector and cable types to connect audio devices. Please always make sure that a connector or cable fits your system before use.

ATTENTION: Never join the phase-inverted (negative, cold or -) poles (either right and left) to the ground or to each other on the output side, as this can damage the unit.

INFO: Use a galvanic isolation in case of a ground loop.

12.8.1. Audio Ports

The Pinout of the 5-pole Phoenix Connector



Pin nr.	Signal
1	Left+
2	Left-
3	Ground
4	Right-
5	Right+

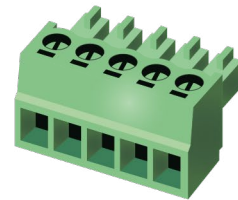

Compatible Plug Type: Phoenix® Combicon series (3.5mm pitch, 5-pole), type: MC 1.5/5-ST-3.5.

From Unbalanced Output to Balanced Input

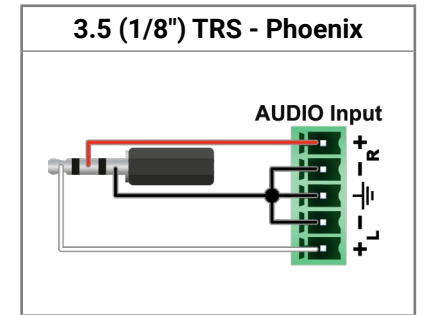
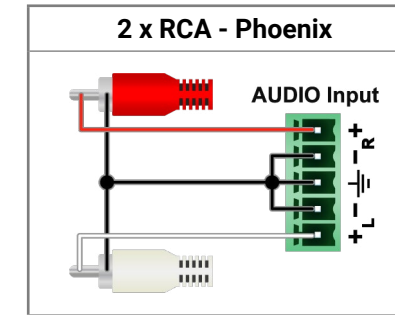
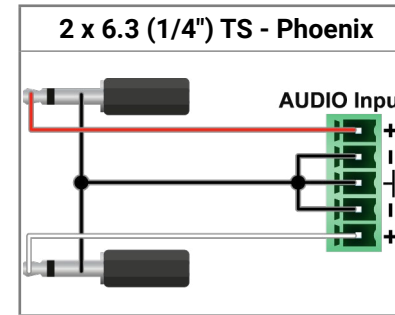

From Balanced Output to Unbalanced Input

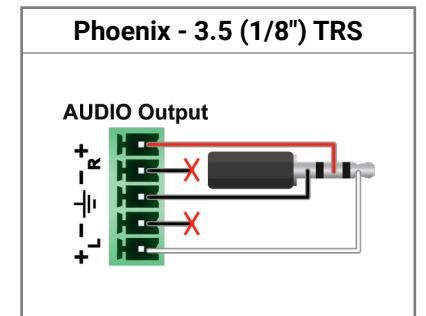
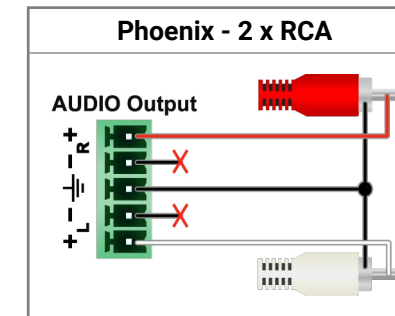
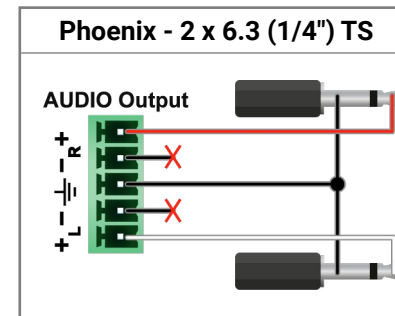

From Balanced Output to Balanced Input

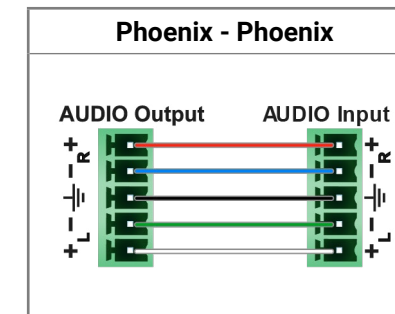
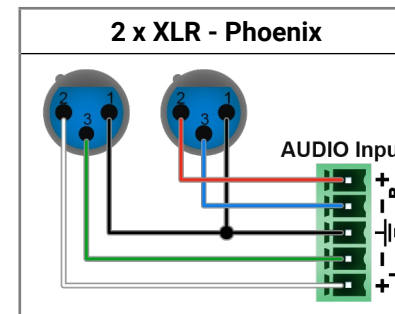
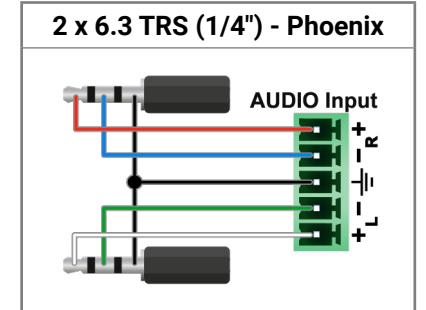
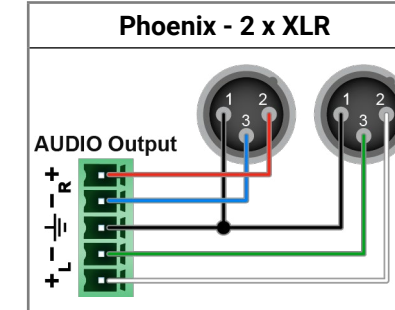
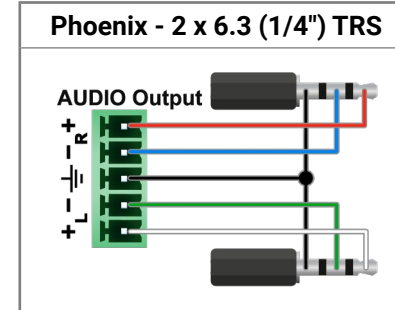

12.9. Mechanical Drawings

12.9.1. MX2M-FR24R

The following drawings present the physical dimensions of the MX2M-FR24R matrix frame. Dimensions are in mm.

Front View (1:4)

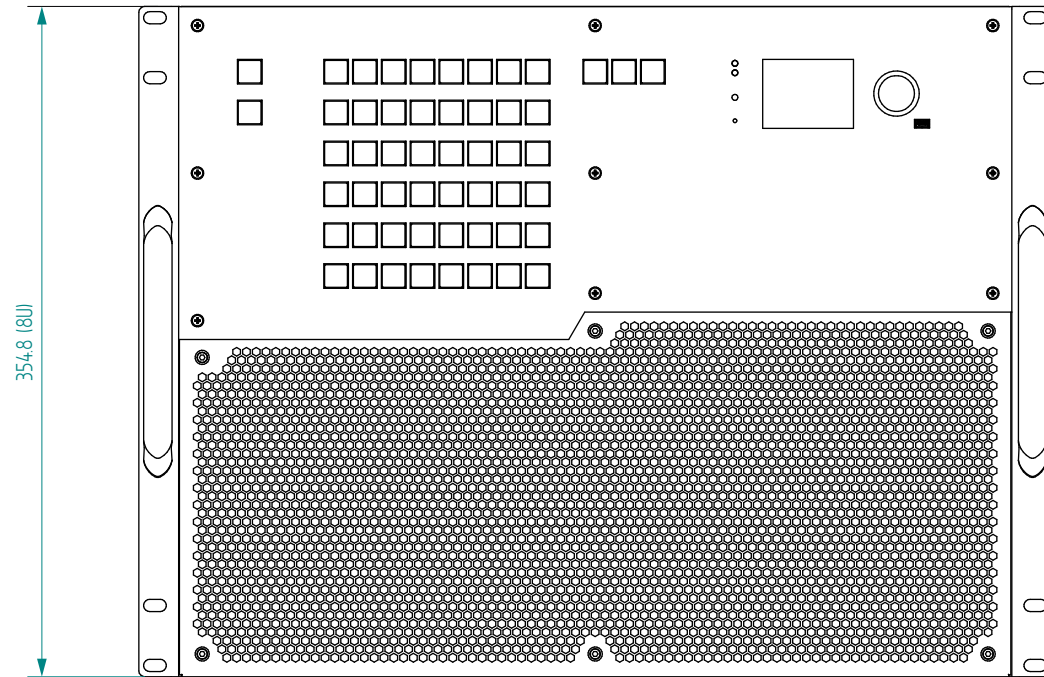

Top View (1:4)

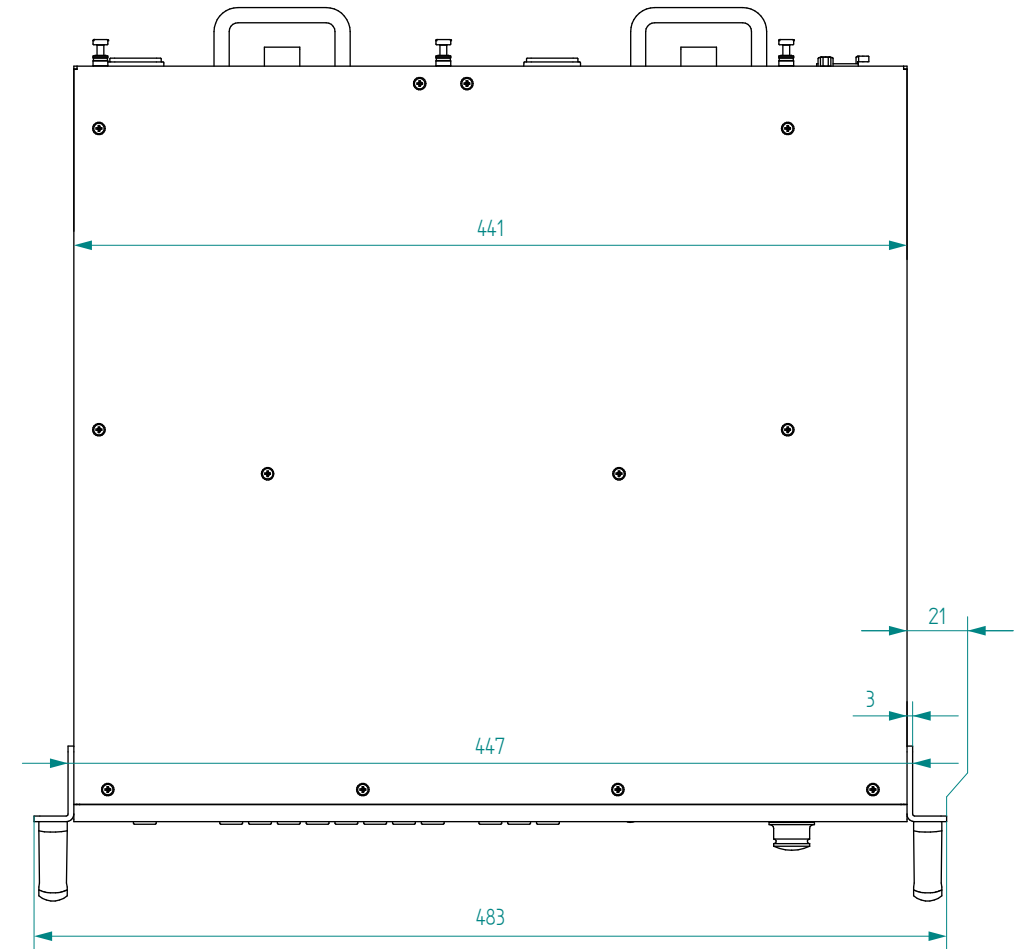

Side View (1:4)

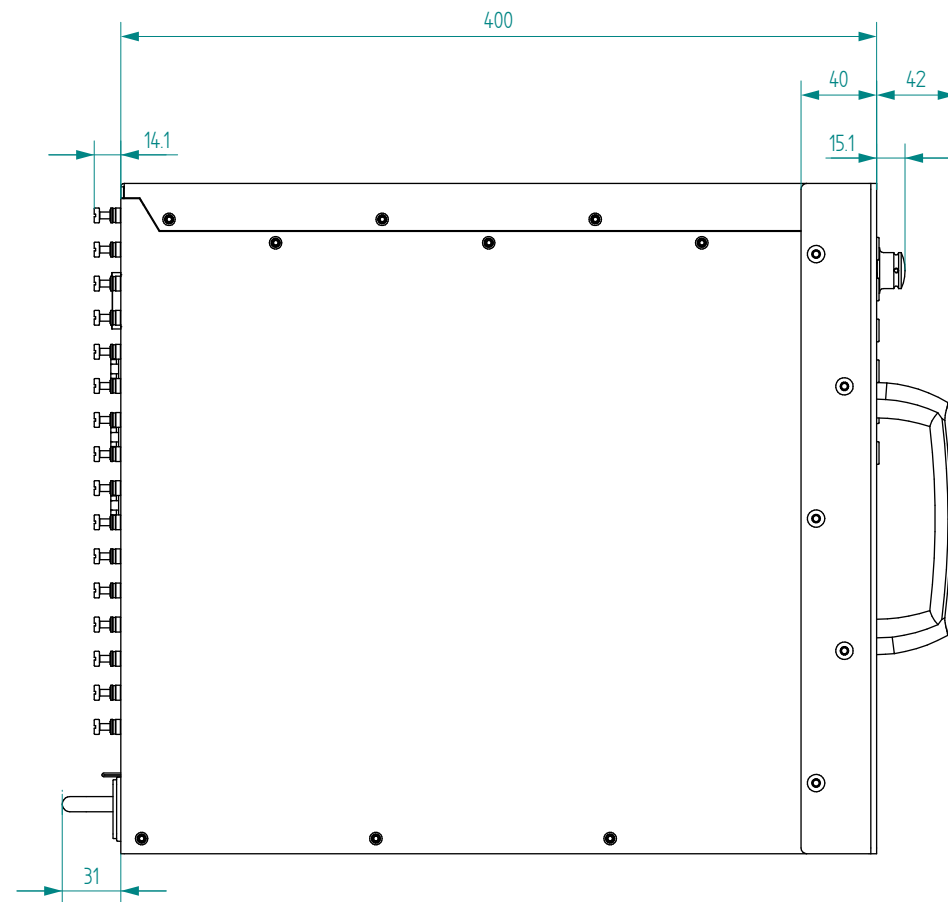

12.9.2. IB/OB Boards

The following drawings present the physical dimensions of the MX2M series input (IB) and output (OB) boards. Dimensions are in mm.

Front View (1:2)

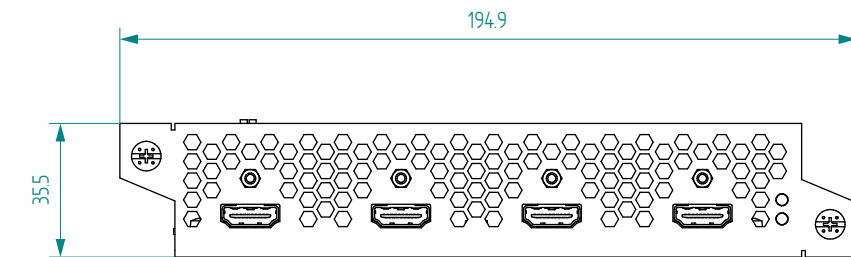

Top View (1:2)

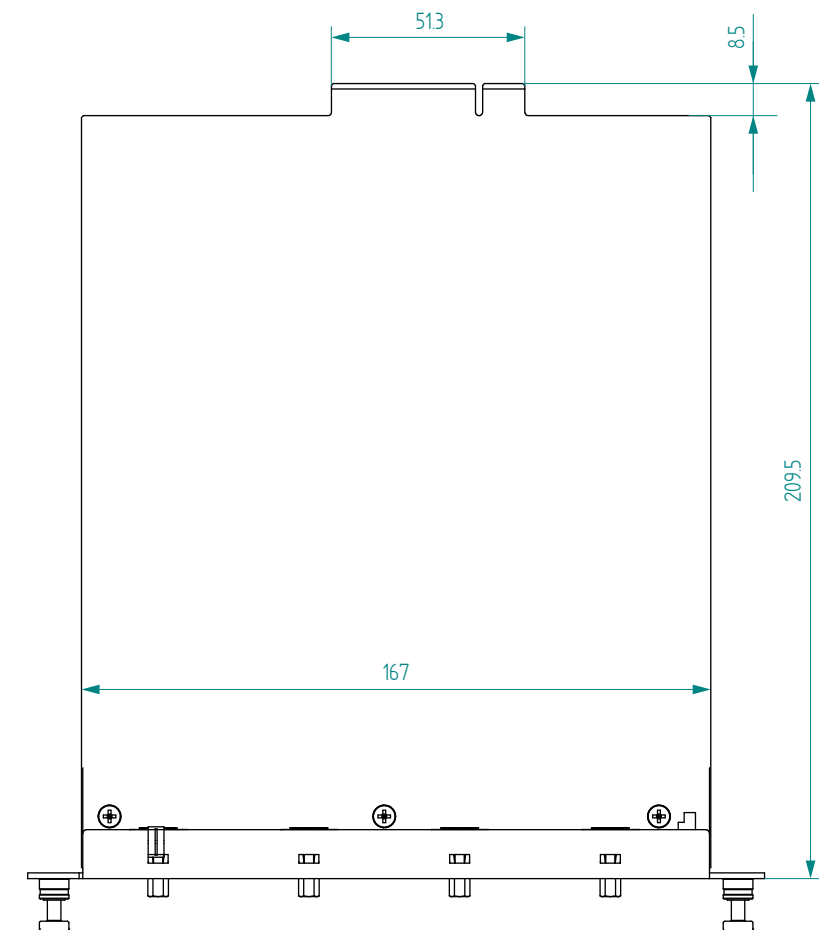

12.9.3. AUX Boards

The following drawings present the physical dimensions of the MX2M series auxiliary (AUX) boards. Dimensions are in mm.

Front View (1:2)

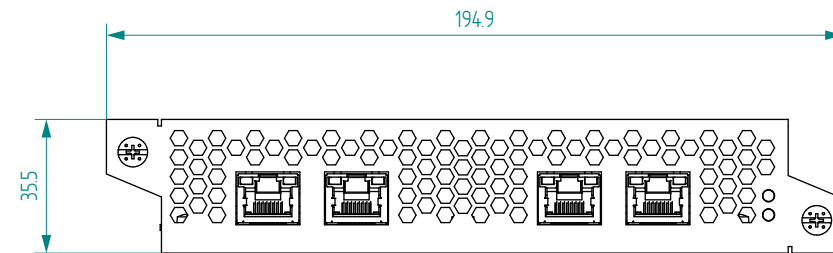

Top View (1:2)

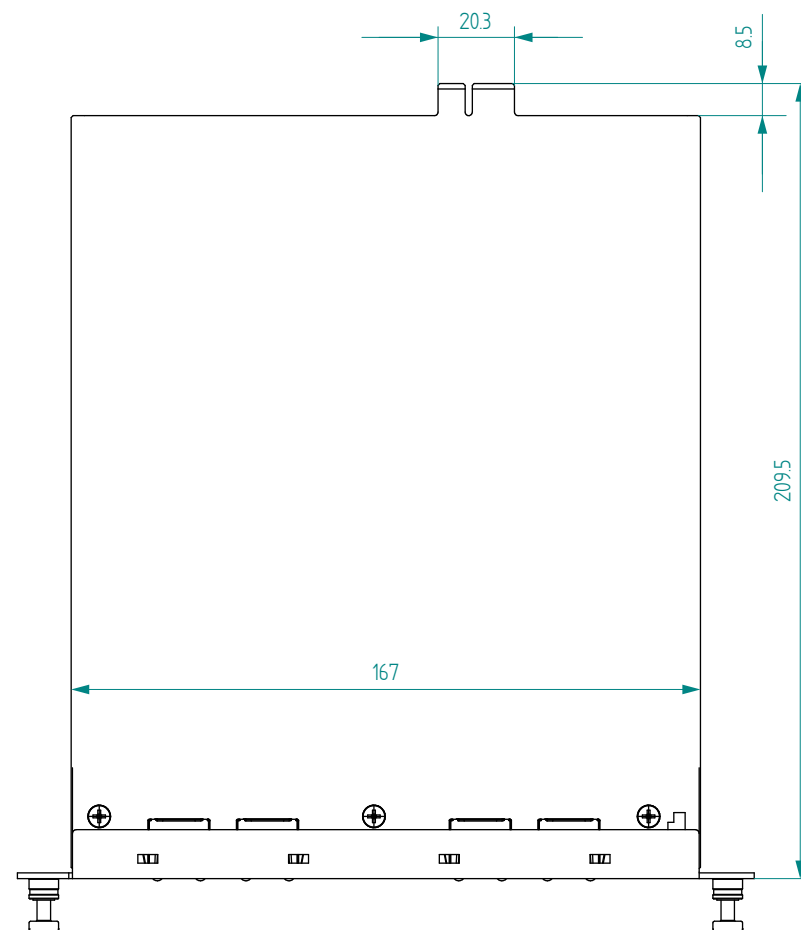

12.10. Release Notes of the Firmware Packages

v1.6.3b4

Release date: 2025-03-17

New feature:

- Upgraded the SDVoE Control Server to version 3.5.

Bugfix:

- Fixed a bug that caused the MX2M modular matrix to get inaccessible in the network.
- Fixed a bug that caused the automatic fan control in the MX2M matrix not to work when the power consumption was high, potentially causing overheating of IO boards.

Known issue:

- When routing audio from channels 3-16 on the input of an MX2M-AUX-DANTE-32CH board to any output boards, no audio will be present on the output. As a workaround, in the Dante Controller, connect (and disconnect, if not needed) a valid Dante stream to the channels 1 and 2 of the respective Dante input.

v1.6.1b1

Release date: 2023-12-14

Bugfix:

- Fixed a bug that might have resulted in unstable signal detection on various input ports of the MX2M-4DP12-IB board.

v1.6.0b7

Release date: 2023-08-22

Bugfix:

- Fixed a bug that resulted in the embedded audio being always indicated as present on the input of an MX2M-4HDMI20-IB or MX2M-4OPTJ-IB board by the graphical user interface.
- Improved on the quality of the video output.

Known issue:

- A switch in the audio crosspoint in the matrix results in an audio glitch on the output boards. Thus, audio switch is not seamless.
- The CEC Controller button on the HDMI-4TPX-IB currently does not work.
- The MX2M-4TPX-OB board might erroneously indicate that the video signal is a non-HDCP signal.
- The image might get unstable for an extended amount of time on the output of a HDMI-TPX-RX107 device connected to the MX2M-4TPX-OB board when an audio crosspoint switch occurs on the respective output port in the matrix.

v1.5.0b9

Release date: 2023-06-02

New feature:

- From this version on, the MX2M-FR24R supports the MX2M-4TPX-IB input board for receiving video, audio and auxiliary data from the HDMI-TPX extender family and from other SDVoE compatible transmitter devices.

Known issue:

- The embedded audio is always indicated as present on the input of an MX2M-4HDMI20-IB or MX2M-4OPTJ-IB board by the graphical user interface. The corresponding LW3 property holds the right value, though,
- DisplayID with version 1 is not supported by the MX2M modular matrix family.
- Connecting multiple MX2M matrices through TPX links results in undefined control state in which neither the standalone LDC nor the embedded web works as expected.
- There is a one-day difference between the actual date stored in the matrix and the actual date set through the graphical user interface.

v1.4.0b13

Release date: 2022-12-15

New feature:

- From this version on, the MX2M-FR24R supports the MX2M-4TPX-OB output board for distributing video, audio and auxiliary data to the HDMI-TPX extender family and to other SDVoE compatible receiver devices.

Known issue:

- No video signal data are shown on the TPX output when the respective output is not connected to a compatible receiver.
- No audio information is available on TPX output ports.

v1.2.1b8

Release date: 2022-03-09

New feature:

- From this version on, MX2M-4HDMI20-IB-E, MX2M-4HDMI20-OB-E, MX2M-4OPTJ-IB-E, MX2M-4OPTJ-OB-E, and MX2M-DH-4DP12-IB-E boards are supported.

Known issue:

- Resetting a port on an MX2M-AUX-DANTE-32CH to its factory default settings has no effect.
- The left and right channels of the stereo audio signal corresponding to a Dante input port on the MX2M-AUX-DANTE-32CH board are swapped.

v1.2.0b6

Release date: 2021-05-13

New feature:

- From this version on, MX2M-4HDMI20-IB, MX2M-4HDMI20-OB, MX2M-4OPTJ-IB, MX2M-4OPTJ-OB, and MX2M-DH-4DP12-IB boards support DisplayID extension in the EDID.

Bugfix:

- Fixed a bug that resulted in wrong board information being displayed in LDC after a firmware upgrade,
- Fixed a bug that resulted in wrong nominal voltage values being reported for the MX2M-AUX-DANTE-32CH board on the Health pages of the graphical user interface.
- Fixed a bug that required to manually alter the secondary mini crosspoint on the output of an MX2M-AUX-DANTE-32CH when the main crosspoint was modified.
- Fixed a bug that resulted in the matrix not being restarted after restoring the configuration.
- Fixed a bug that resulted in invalid backup file being uploaded to the matrix switcher.
- Fixed a bug that caused the embedded web and the LDC application to generate an invalid backup file.
- Fixed a bug that resulted in escape backslashes being added to the channel labels with opening or closing brackets on an MX2M-AUX-DANTE-32CH board.
- Fixed a bug that prevented the channel label on an MX2M-AUX-DANTE-32CH board from being updated through the graphical user interface.
- Fixed a bug that prevented the restore operation issued through the graphical user interface from being completed.
- Added the Switch to all command to input ports of the MX2M-AUX-DANTE-32CH board on the graphical user interface.

Known issue:

- If the matrix switcher is set up to use dynamic IP address allocation through DHCP and a different IP address is assigned to it by the DHCP server when the lease is renewed, the matrix switcher remains accessible through both the old and the new IP address.
- Factory resetting the individual ports does not work. Moreover, after factory resetting an individual board might not reset some parameters.
- The update of MX2M-4OPTJ-IB and MX2M-4OPTJ-OB boards might fail if the optical cables are connected during the update process. Should this be the case, unplugging the optical cables and restarting the matrix resolves the problem and the update gets finished successfully.
- For video signals having a width of 4096 pixels or more, the video format returned is invalid. Such video signals are passed through the matrix switcher without any problem, it is just the format indication that is invalid.
- The information on the color space of the video signal arriving at the input port might not get propagated to the output port. This results in invalid color space information in the output video signal. Manually triggering a hotplug event on the input restores the valid color space information on the output.

v1.1.0b13

Release date: 2021-02-15

New feature:

- From this version on, the matrix firmware supports the MX2M-AUX-DANTE-32CH board.
- From this version on, CEC is supported by the video IO boards.

Bugfix:

- Fixed a bug that caused some sink devices (displays) to fail to synchronize to the video stream if they are fed through an HDMI20-OPTJ-RX90 from an MX2M-4OPTJ-OB board.
- Fixed a bug that caused some ports on the MX2M-4OPTJ-OB output board not to function correctly.

Known issue:

- The channel labels of the input and output ports on the MX2M-AUX-DANTE-32CH board are not reset when the Dante device corresponding to the respective board is factory reset from the Dante Controller.
- The matrix might report invalid link status for the Primary and Secondary interfaces on an MX2M-AUX-DANTE-32CH board.
- It might happen, that after switching on and off the input signal many times the input port on a video input board erroneously reports a valid HDMI signal.
- When changing the source for an output port on the MX2M-AUX-DANTE-32CH board, the secondary mini crosspoint on the respective output also has to be altered to get the audio content corresponding to the new source out from the board.
- The manual showing the usage of PriLinkType and SecLinkType properties erroneously states that the accepted values are numbers. Use the strings corresponding to the values to set the link type.
- After a firmware upgrade, wrong board information is displayed in LDC. Restarting LDC resolves the issue.
- Wrong nominal voltage values are reported for the MX2M-AUX-DANTE-32CH board on the Health pages of the graphical user interface.

v1.0.0b33

Release date: 2020-10-02

Known issue:

- Color space conversion to YCbCr 4:2:2 on the output might result in invalid picture if the color space format of the incoming video signal is 4:2:0.
- The audio embedded by a video output board (e.g. MX2M-4HDMI20-OB) into the output HDMI stream cannot be decoded by a less error resilient player device (like a HDMI receiver). The same audio is played back seamlessly and without any problem by a regular television.
- The audio cannot be de-embedded from the input video on an MX2M-4HDMI20-IB or MX2M-4OPTJ-IB board when the source of the input video is an output board and the respective output is set to embed

audio from the Audio layer.

- It might take an unusually long time for some sink devices (displays) to synchronize to the video stream if they are fed through an HDMI20-OPTJ-RX90 from an MX2M-4OPTJ-OB board.
- The output video stream might contain wrong audio channels when zero or one channel is selected for embedding in the output video stream on video output boards.
- Presets created via the front panel are displayed as audio presets on the embedded web and in the LDC application.
- The audio input ports on an MX2M-AUX-8AUDIO board cannot be muted.

12.11. Hashtag Keyword List

This user manual contains keywords with hashtags (#) to help you find the relevant information as quick as possible.

The format of the keywords is the following:

#<keyword>

The usage of the keywords: use the **Search** function (Ctrl+F / Cmd+F) of your PDF reader application, type the # (hashtag) character and the wished keyword.

The **#new** special keyword indicates a new feature/function that has just appeared in the latest firmware or software version.

Example

#dhcp

This keyword is placed at the DHCP (dynamic IP address) setting in the front panel operation, the Lightware Device Controller (LDC) and the LW3 programmer's reference section.

The following list contains all hashtag keywords placed in the document with a short description belonging to them. The list is in **alphabetical order** by the hashtag keywords.

Hashtag Keyword ↓	Description
#advancedview	Terminal (advanced view) window
#aes67	Dante/AES67 audio related settings
#analogaudio	Analog audio related settings
#audio	Audio related settings
#autotakemode	Autotake mode
#backup	Configuration cloning (backup)
#balance	Balance (for analog audio) setting
#builtinweb	Built-in web
#button	Front panel button operations
#cec	CEC related settings
#channelmapping	Audio channel mapping setting
#colorrange	Color range setting
#colorspace	Color space converter related settings
#controllock	Front panel control lock
#crosspoint	Crosspoint switch setting
#dante	Dante/AES67 audio related settings
#date	Date setting

Hashtag Keyword ↓	Description
#devicelabel	Device label
#dhcp	Dynamic IP address (DHCP) setting
#displayid	DisplayID related settings
#displayport	DisplayPort related audio/video setting
#dp	DisplayPort related audio/video setting
#dppower	DisplayPort power send setting
#edid	EDID related settings
#embedder	Audio embedder (audio source) setting
#factory	Factory default settings
#firmwareversion	Firmware version query
#framedetector	Frame detector in LDC/built-in web
#gain	Gain (for analog audio) setting
#hdcp	HDCP-encryption related setting
#hdmi	HDMI related audio/video setting
#health	System monitoring (health) related information
#hotplugdetect	Hot plug detect setting
#hpd	Hot plug detect setting
#ipaddress	IP address related settings
#label	Device label
#license	License settings
#linktraining	DisplayPort link training setting
#lock	Port lock settings
#log	System log
#mapping	Audio channel mapping setting
#mute	Port mute setting
#network	Network (IP address) related settings
#nosyncscreen	Test pattern (no sync screen) settings
#optj	OPTJ related audio/video setting
#outputlock	Front panel output lock
#poe	PoE (Power over Ethernet) related settings
#power5v	Power 5V mode setting

Hashtag Keyword ↓	Description
<i>#preset</i>	Preset related settings
<i>#producttype</i>	Product type query
<i>#reboot</i>	Restarting the device
<i>#reset</i>	Restarting the device
<i>#restart</i>	Restarting the device
<i>#restore</i>	Configuration cloning (restore)
<i>#serialnumber</i>	Serial number query
<i>#softreset</i>	Software resetting of the device
<i>#status</i>	Status query
<i>#switch</i>	Crosspoint switch setting
<i>#systemmonitor</i>	System monitoring (health) related information
<i>#takemode</i>	Take mode
<i>#terminal</i>	Terminal (advanced view) window
<i>#testpattern</i>	Test pattern (no sync screen) settings
<i>#time</i>	Time setting
<i>#tpx</i>	TPX (SDVoE AVX) related settings
<i>#unlock</i>	Port unlock settings
<i>#unmute</i>	Port unmute setting
<i>#volume</i>	Volume (for analog audio) setting
<i>#web</i>	Built-in web

12.12. Further Document Information

Symbol Legend

The following symbols and markings are used in the document:





- **WARNING! Safety-related information that is highly recommended to read and keep in every case!**
- **ATTENTION:** Useful information for performing a successful procedure; it is recommended to read.
- **DIFFERENCE:** Feature or function that is available with a specific firmware/hardware version or product variant.
- **INFO:** A notice, which contains additional information. Procedure can be successful without reading it.
- **DEFINITION:** The short description of a feature or a function.
- **TIPS AND TRICKS:** Ideas that you may have not known yet, but can be useful.

Navigation Buttons

Buttons in the PDF version

	Navigate to the Table of Contents .
	Go back to the previous page . If you clicked on a link previously, you can go back to the source page by pressing the button.
	Navigate to the Bookmark page .
	Visit www.lightware.com .

Buttons in the HTML version

	Open the main Table of Contents .
	Navigate to the Online User Manuals webpage.
	Navigate to the Bookmark page in this User Manual.
	Download the PDF version of the User Manual.

About Printing

Lightware Visual Engineering supports green technologies and eco-friendly mentality. Thus, this document is made primarily for digital usage. If you need to print out a few pages for any reason, follow the recommended printing settings:

- Page size: A4
- Output size: Fit to page or Match page size
- Orientation: Landscape

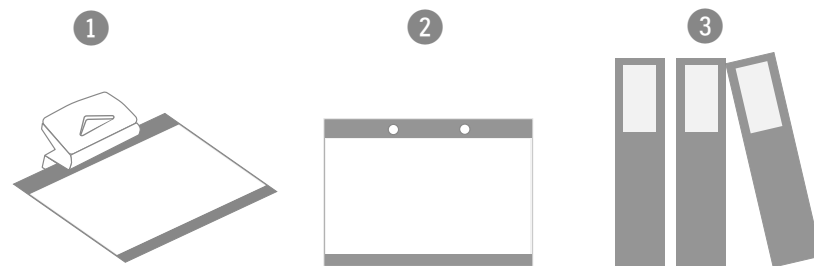

TIPS AND TRICKS: Thanks to the size of the original page, a border around the content (gray on the second picture below) makes it possible to organize the pages better. After punching holes in the printed pages, they can easily be placed into a ring folder.

12.13. Limited Warranty Statement

1. Lightware Visual Engineering PLC (Lightware) warrants to all trade and end user customers that any Lightware product purchased will be free from manufacturing defects in both material and workmanship for three (3) years from purchase unless stated otherwise below. The warranty period will begin on the latest possible date where proof of purchase/delivery can be provided by the customer. In the event that no proof can be provided (empty 'Date of purchase' field or a copy of invoice), the warranty period will begin from the point of delivery from Lightware.

1.1. 25G and MODEX product series will be subject to a seven (7) year warranty period under the same terms as outlined in this document.

1.2. If during the first three (3) months of purchase, the customer is unhappy with any aspect of a Lightware product, Lightware will accept a return for full credit.

1.3. Any product that fails in the first six (6) months of the warranty period will automatically be eligible for replacement and advanced replacement where available. Any replacements provided will be warranted for the remainder of the original unit's warranty period.

1.4. Product failures from six (6) months to the end of the warranty period will either be repaired or replaced at the discretion of Lightware. If Lightware chooses to replace the product, then the replacement will be warranted for the remainder of the original unit's warranty period.

2. The above-stated warranty and procedures will not apply to any product that has been:

2.1. Modified, repaired or altered by anyone other than a certified Lightware engineer unless expressly agreed beforehand.

2.2. Used in any application other than that for which it was intended.

2.3. Subjected to any mechanical or electrical abuse or accidental damage.

2.4. Any costs incurred for repair/replacement of goods that fall into the categories above (2.1., 2.2., 2.3.) will be borne by the customer at a pre-agreed figure.

3. All products to be returned to Lightware require a return material authorization number (RMA) prior to shipment, and this number must be clearly marked on the box. If an RMA number is not obtained or is not clearly marked on the box, Lightware will refuse the shipment.

3.1. The customer will be responsible for in-bound, and Lightware will be responsible for out-bound shipping costs.

3.2. Newly repaired or replaced products will be warranted to the end of the originally purchased product's warranty period.