

# Mounting and manual instruction FS-QR120 E floor stand

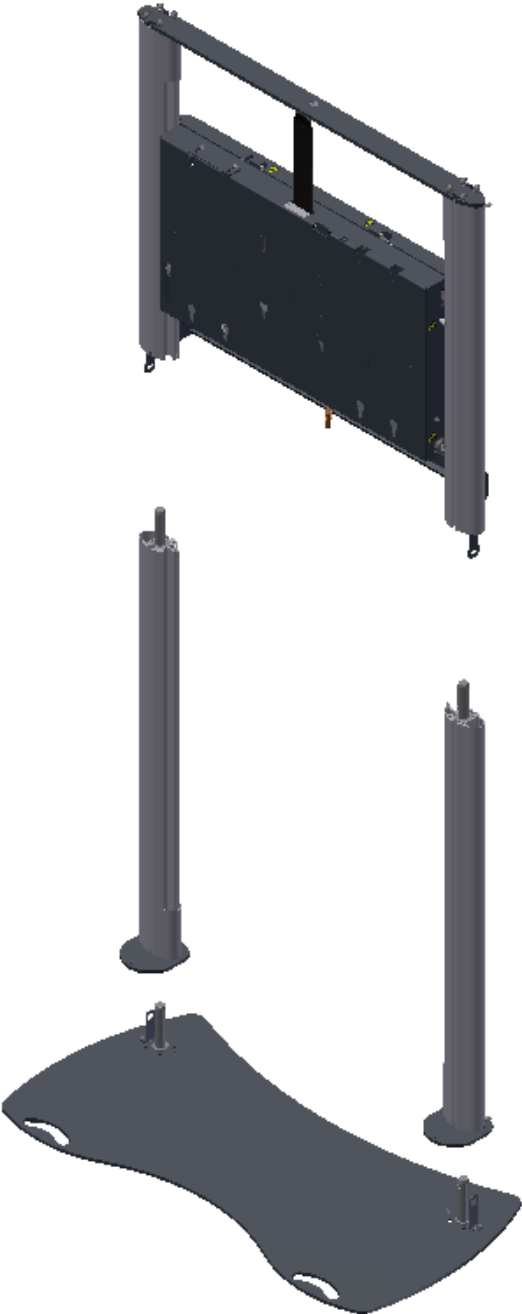

**The FS-QR120E is a quick-release demountable floor stand with integrated lifting mechanism that raises the flat panel out of the flightcase for you.**

**Check at arriving of your package that your product isn't damaged. With damage please report directly to the transporter and Audipack to provide a quick solution.**

**It is important that at first use the lowest lifting head position is set to the correct height. This is important because the cams on the back of the Audipack bracket on the back of the flat panel should correspond with the key holes of the lifting head in lowest position.**

***Please read the manual in full before starting to assemble the floor stand.***

**1.**

Take away both flightcase lids and assemble the floorstands floor plate on the desired position.

Make sure the floor plate is positioned on a level and flat surface.



**2.**

Install the 2 lower columns on the floor plate.

Take away the C-formed covers (if needed) and secure the poles with the lock. Be sure to install the columns with the "lip" front wards (see picture).

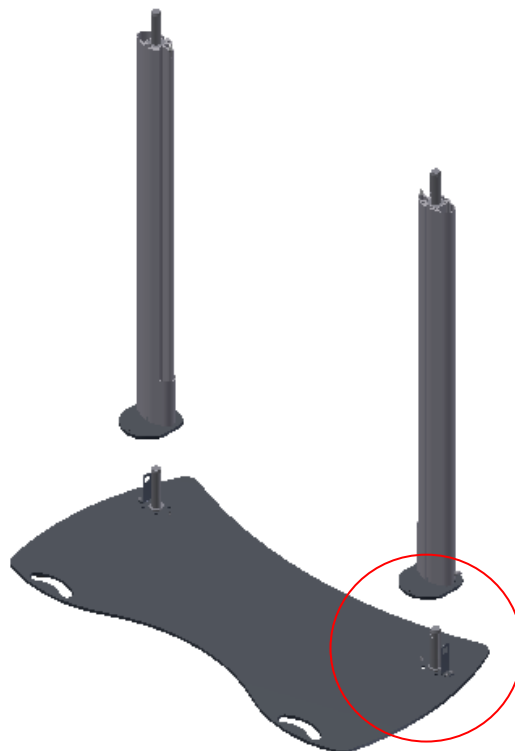

**3.**

Install the top part with the lifting head. Be sure to grip the handle and the side of the columns. Do not lift at the lifting head!!

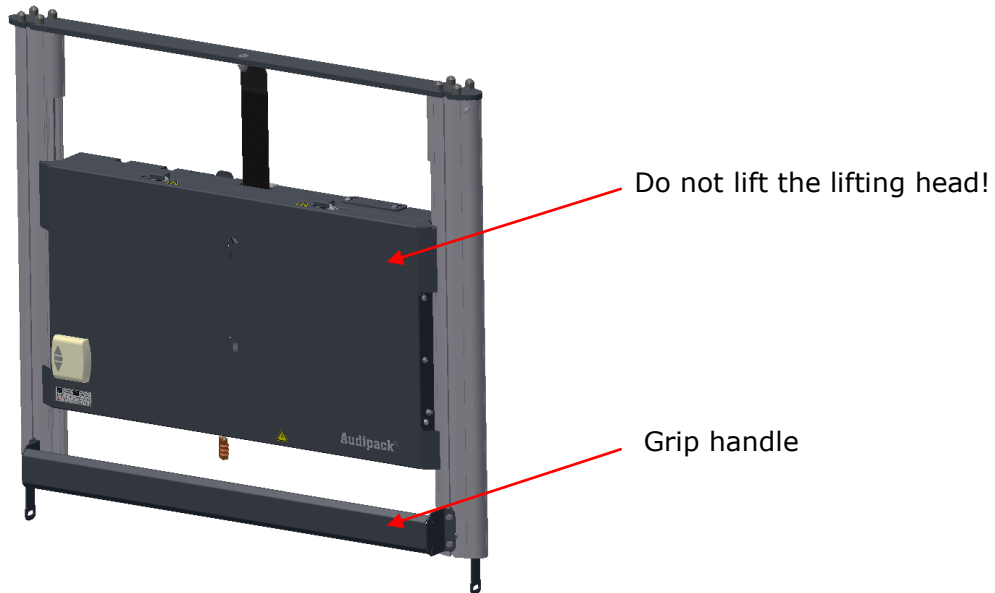

Make sure both pins slide in equally.  
At uncontrolled placing it might be more difficult to connect the columns.  
Also lock this assembly with the locks (tip: lock after full completion)

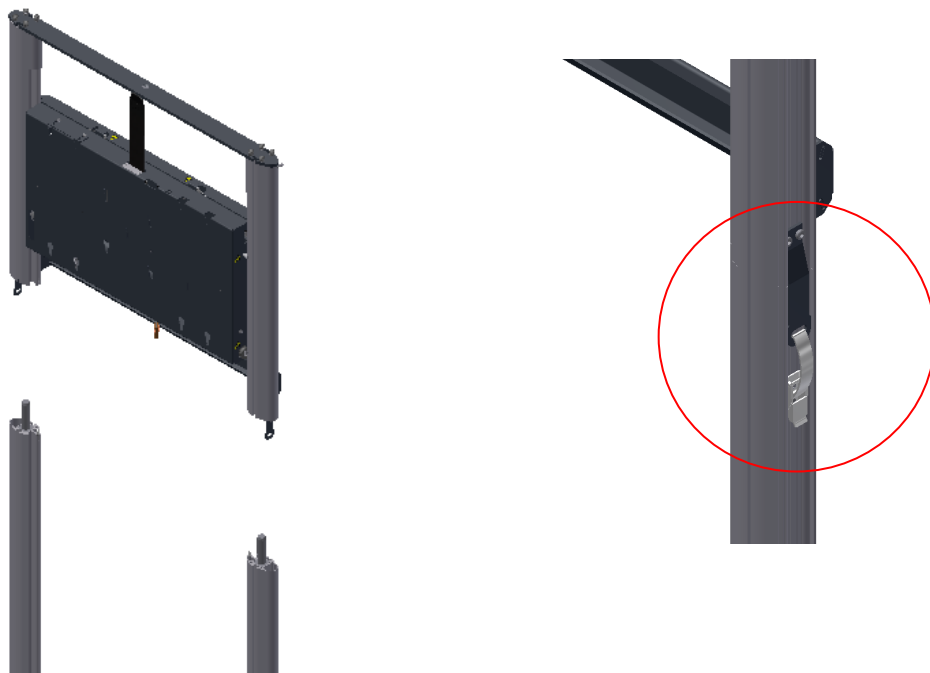

**4.**

Plug in the power supply at the bottom of the lifting head.  
Lower the lifting head to the lowest position by pressing the lowest button on the back.

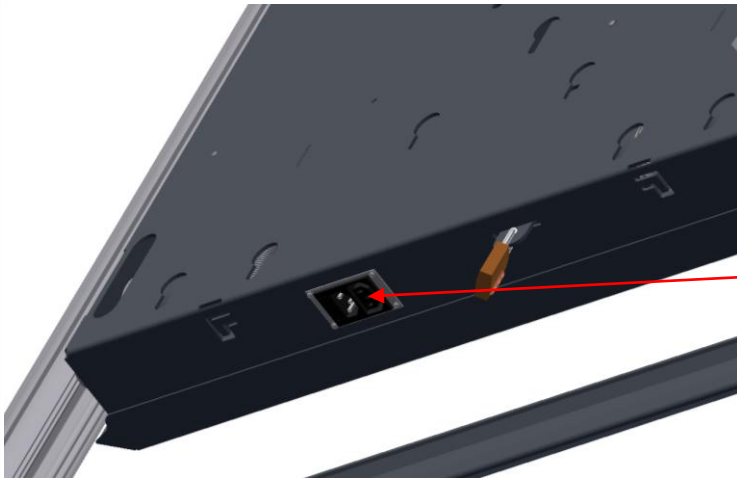

230 volt power inlet with  
loop to the monitor

*"The right height is the height where the cams of the bracket are equally high as the key holes in the lifting head".*

**5.**

Take the flightcase and move the back side of the flat panel in front of the floor stand. Hook in the cams and press the lifting button. Stop the flat panel at any desired height by pressing the middle button.

See chapter 6. for using the right mounting pattern and applicable loads.

## 6.

Flat panel heavier than 85 Kg must use the VESA 400 or 600 mounting pattern of the system. When the screen is equipped with an equal mounting pattern on the back, please contact Audipack for a fitting interface bracket.

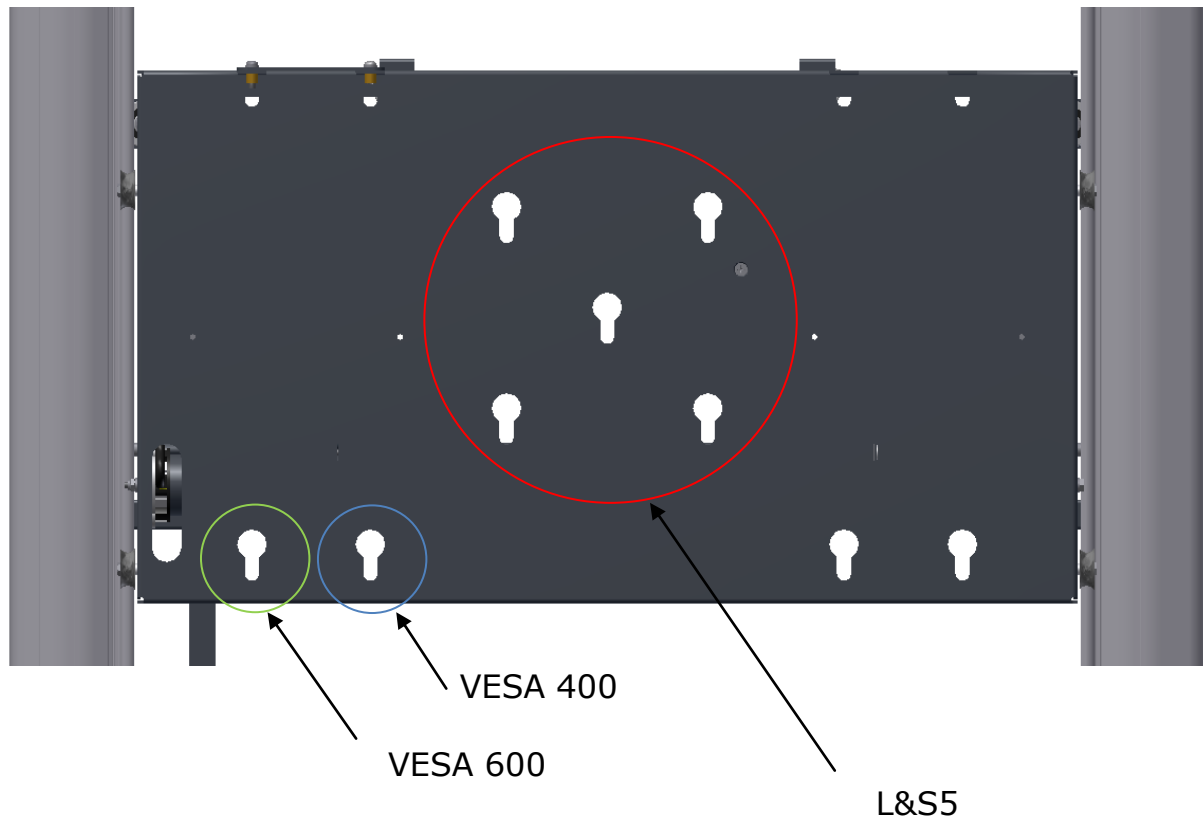

### Applicable loads:

VESA 400 max. load 120 Kg

VESA 600 max. load 120 Kg

L&S5 max. load 85 Kg (with UFPRO)

### **Flat panel installation with VESA interface and cams.**

When the flat panel is equipped with a VESA interface according the example, the screen can be installed with the cams inserted directly in the back.

Choose one of the below (optional) cams to insert in the back.

**M6** part no. 392618

**M8** part no. 392318

**M10** part no. 390618



## 7.

Flat panel security.

When the flat panel is installed it is possible to lock it onto the lifting head.

Release the screws on the top to slide away or position the cover plate.

In case of using the standard L&S5 interface a single padlock can be used to secure the set.

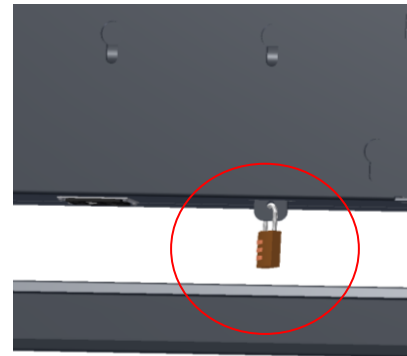
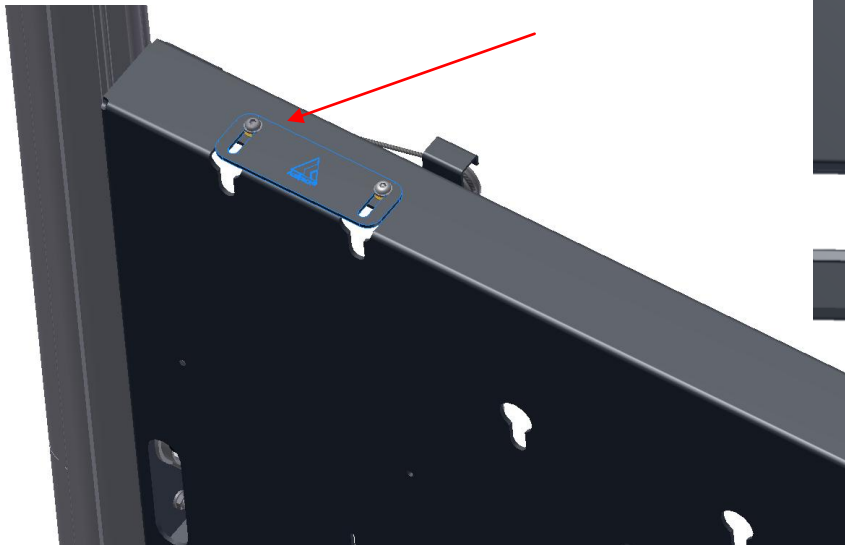

## 8. Maintenance / fine tuning.

It is possible to correct the horizontal level of the floor stand.

It might be possible after a while it must be corrected.

Take away the C-cover and adjust the M8 screw.

Hold down the cable, do not let it rotate while adjusting the M8 bolt.

This might result in a twisted cable.

Use wrench **13 mm** to adjust.

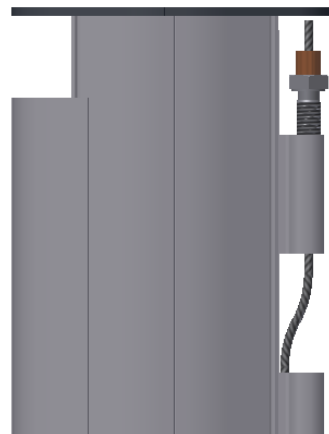

## 9. Adjusting the lowest height at first use.

Be aware that it might be possible your model is equipped with 2 version of adjustment. Please see chapter **9b** when the lift is equipped with an electronic height adjustment. The difference is that the electronic version has NO yellow and white adjustment knobs as illustrated below.

When the Total system is installed please plug in the power.  
The system is equipped with a wireless transmitter mounted on the back.  
The system it selve is already set to standard limits. Never adjust the upper limit!



At the front of the lifting head coloured knobs are visible. With an alan key the positions can be set by adjusting their position.

### **Adjusting the upper limit:**

White knob,

While giving command up adjust the white knob with an alan key. Check left and right turning for adjusting the right direction.

### **Adjusting lower position:**

Yellow knob,

While giving command up adjust the yellow knob with an alan key. Check left and right turning for adjusting the right direction.

### **Attention!**

**When adjusting the motor limit, be aware that mechanical limits may damage the motor by setting the limits too far.**

**The motor can be overloaded and damage.**

**Max. motor runnig time 4 minutes.**

**Cooling down time 9 minutes at 4 minutes use.**

**Be sure that all parts move and rotate free.**

**Disconnect power after installation.**

## 9b.

This procedure is only applicable for FS-QR with electronic height adjustment setting.

During testing the system is already set to maximum limits.

For the first use the lifting head must be set in height to let the cams from the monitor bracket insert into the key holes of the lifting head (while the flat panel is still in the flightcase).

### **Be aware of adjusting the bottom height for the DFS before installing the monitor!**

Work along the below protocol to set the right height.

Adjusting new lower position (only upwards).

- Plug in power and lower the lifting head to its lower limit.
- Use the rear mounted transmitter to control the system.
- Press the buttons UP and DOWN at the same time until the mounting head moves up-and down shortly (program mode).
- Press single up to set the new height.
- For storing this position press the middle until the mounting head moves up-and down shortly.
- The new position is set.





### **Technical details:**

FS-QR120E

Maximale load:

-85 Kg with L&S5 mounting interface

-120 Kg with VESA 400 and 600 interface (with cams)

Power supply 230 VAC 50-60 Hz

Max. Motor running time 4 minuten (9 minuten "cool-down" period)

For questions or service please contact

**Audipack**

079-5931671

Technical department

### **Notes:**

## Re-programming the controll buttons (pairing).

All systems are pre-programmed in the factory.

When a new transmitter must be paired to the system check below protocol to perform the "pairing".

- Take out the transmitter from the system.
- Unplug the power for 20 seconds
- Plug in power for 10 seconds
- Unplug power for 2 seconds
- Plug back in the power, the motor will rotate for a few seconds.
- When the motor has stopped, press the small "prog"button on the back of the PCB (see picture).

Programm button

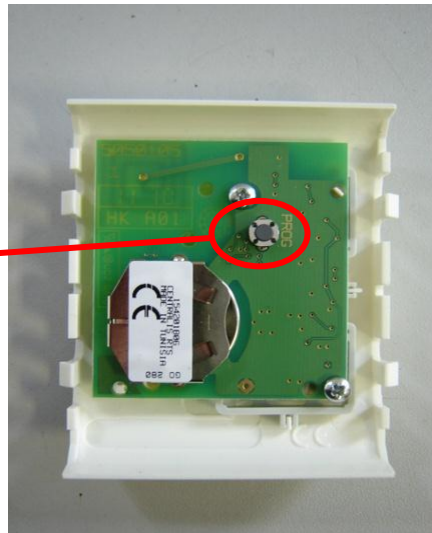

- The motor will rotate left and right shortly

When the system does not respond to the command, a red light will blink on the remote.

- Check the battery and replace it.
- Plug in main power of the system.



Function LED

**Audipack**  
Industriestraat 2  
2751 GT  
Moerkapelle  
+31(0)79 593 1671